

# NEXUS™ Control System

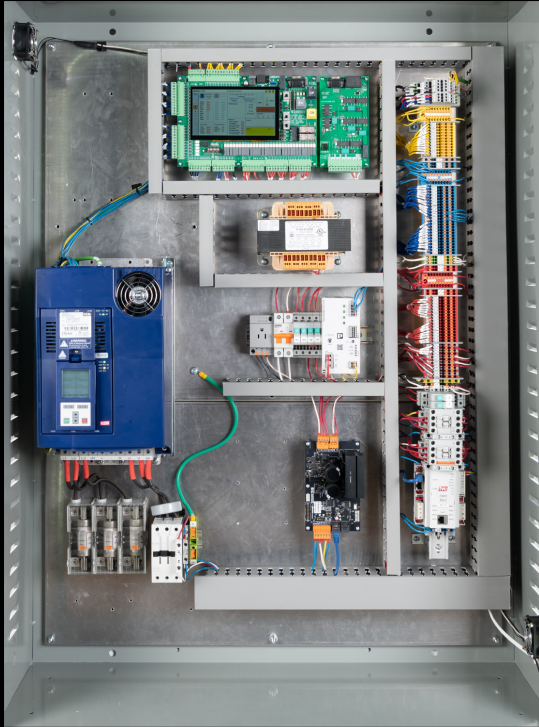

## INSTALLATION MANUAL

---

**DOC-0003**  
**Version 1.4**  
**3/2026**



50 E. 153rd St.  
Bronx, NY 10451-2104  
Ph: 718.292.9000  
Fax: 718.292.2034  
vantageelevation.com



Chicago	877.300.5830
New York	917.336.4597
Miami	877.241.9354
L.A.	877.300.5816
Dallas	469.706.9316
Toronto	888.425.2262

## Foreword

Vantage Elevation has developed this manual with usability and safety as top priorities. However, as noted below, this product may present inherent risks if not used in strict accordance with the instructions provided in this manual. It is essential that all users read and fully understand these instructions prior to and during installation and use.

Before installation or servicing, ensure that the power supply is disconnected, and the area is secure from unauthorized access. Always wear appropriate personal protective equipment (PPE) when handling or servicing the equipment. For any uncertainty related to installation or operation, consult a qualified professional or contact Vantage Elevation.

The user assumes full responsibility for any injuries, damages, or losses to persons or property resulting from negligent, improper, unintended or unforeseeable use of this product. This includes, but is not limited to, failure to follow the safety precautions and operational instructions outlined in this manual.

By using this product, the user acknowledges and accepts these risks, waives any and all claims against Vantage Elevation the user may have due to such risks, and agrees to indemnify and hold harmless Vantage Elevation, its affiliates, and distributors against any claims, damages, losses, or expenses incurred and/or arising from the user's failure to follow the instructions and safety protocols in this manual. Specific warnings are detailed on the following pages and the user must heed these warnings in full prior to use of the product, which installation and use must be pursuant to the instructions contained herein.

Copyright © Vantage Elevation 2025. All drawings, illustrations, and information herein are the property of Vantage Elevation and/or the respective third-party rights holder(s).

### Document History

DATE	VERSION	CHANGES	CHANGES MADE BY
3/18/2025	1.1	Updated UI for Hoistway view Added USB update steps	Sam Neel
12/9/2025	1.2	Update Construction Mode	Sam Neel
2/4/2026	1.3	Added traction elements	Sam Neel
3/24/2026	1.4	Updated traction parameters	Sam Neel

## Symbols Used in this Manual



### CAUTION

This manual uses the **CAUTION** symbol to identify procedures and practices that may result in personal injury and/or equipment damage, if not followed correctly.

---



### DANGER

This manual uses the **DANGER** symbol as an alert to a danger of electrocution or an acute electrical shock. The **DANGER** symbol provides elevator personnel with a warning of severe personal injury or potential fatality that can result if safety precautions are not observed.

---



### NOTE

This manual uses the **NOTE** symbol to indicate additional useful information.

---

## DANGER AND CAUTION NOTES

---



All installation and wiring must meet national electrical code, all local codes, and all elevator safety codes and standards. The 3-phase AC power supply to the equipment must originate from a properly fused disconnect or circuit breaker that is properly designed and sized for the specific controller requirements and the Short Circuit Current Rating listed on the controller. Improper motor branch circuit protection voids the warranty and may create hazardous conditions.

---



Wiring to the controller terminals must be installed in a neat, careful manner. Stranded wire conductors must not leave strands out of the terminals, as this can create a potential short circuit. All terminals and cable connectors must be seated properly.

---



Elevator control products must be installed by elevator personnel trained in the construction, maintenance, repair, inspection, and testing of elevator equipment. The elevator personnel must comply with all applicable safety codes and standards. This equipment is an OEM product designed and manufactured to comply with ASME A17.1 and A17.5/CSA B44 Safety Code for Elevators and Escalators. The installer is responsible for ensuring that the installation is performed safely and complies with all applicable codes.

---



Proper grounding is vitally important to the safe and successful operation of this system, and proper grounding should be installed to comply with all applicable codes. A separate ground wire should be installed from the building earth ground to the earth ground terminal in each controller. Proper conductor size must be used for grounding. To minimize resistance to ground, the shortest possible length should be used for the ground conductor.

---



Do not install the controller in a hazardous area where excessive vapors and chemical fumes are present. Do not install the controller in a dusty area. Do not install the controller in a carpeted area. The space in which the controller equipment is installed should be temperature controlled, moisture free, and maintained within a temperature range of 32°/0°C and 110°F/43°C. The space in which the controller equipment is installed should be kept clean. The controller should be kept dry and should not be exposed to moisture or water condensation. Make sure the power supply voltage feeding the controller equipment does not fluctuate by more than +/- 10%.

---



Every safety precaution, whether specifically stated in this document, must be implemented when installing, adjusting, or servicing elevator equipment. All safety precautions must be followed to ensure the safety of elevator personnel and the public.

---



Use only the correct rated fuses or breakers for controller protection. Use of improperly rated fuses or breakers voids the warranty.

---



Always use all appropriate Lockout/Tagout procedures as per your company policies and Authority Having Jurisdiction (AHJ) regulations while doing any installation, calibration or maintenance work, or any other time the system is in Construction Mode.

---

# CONTENTS

<b>Foreword</b> .....	<b>2</b>
<b>Symbols Used in this Manual</b> .....	<b>3</b>
Danger and Caution Notes .....	4
<b>CONTENTS</b> .....	<b>5</b>
<b>Section 1 Product Description</b> .....	<b>10</b>
1.1 Product Code Compliance .....	10
1.2 Specifications .....	10
1.2.1 Standard Features .....	10
1.2.2 Optional Features .....	11
1.2.3 Environment .....	11
1.3 Reference Materials Needed .....	11
1.4 Enclosure Layout .....	12
1.4.1 Machine Room Enclosure Layout - Hydraulic .....	12
1.4.2 Machine Room Enclosure Layout - Traction .....	13
1.4.3 Cartop Box Layout .....	14
1.5 Controller Board Overviews .....	15
1.5.1 Machine Room (MR) Board – NEXS-0001 .....	15
1.5.2 Valve-Brake Relay (VBR) Board – NEXS-0002 .....	17
1.5.3. Car Top (CT) Board – NEXS-0003 .....	19
1.5.4 Car Operating Panel (COP)/Expansion (I/O)/Riser (Group) Board – NEXS-0004 .....	21
1.5.5 DC Brake (DCB) Board – NEXS-0014 .....	24
1.5.5 Hall Board (HB) – NEXS-0005 .....	26
1.5.5.1 Simplex .....	26
1.5.5.2 Group .....	26
1.5.5.3 Inputs .....	27
1.5.5.4 Outputs .....	27
1.5.5.5 Functions and Address Settings .....	27
1.5.5.6 LED Indicators .....	27
1.5.5.7 Self-Test Mode .....	27
Controller Network Block Diagram .....	28
1.6 User Interface .....	29
1.6.1 Home Screen .....	29

1.6.1.1 Car Door Status .....	29
1.6.1.2 Hall Door Status .....	30
1.6.1.3 Network Status .....	30
1.6.1.4 Motion state: .....	30
1.6.1.5 Input and Output (I/O) monitoring: .....	31
1.6.1.6 Position Indicator (PI) and Door Zone (DZ) .....	31
1.6.1.6.1 Hoistway View .....	32
1.6.1.6.2 Adjust Screen .....	32
1.6.1.6.3 Status Screen .....	33
1.7 Sequence of Operation .....	34
1.7.1 Car Moving Up Run Sequence - Hydraulic .....	34
1.7.2 Car Moving Down Run Sequence - Hydraulic .....	35
1.7.3 Car Motion Pre-Run Sequence - Traction .....	36
1.7.4 Car Motion Post-Run Sequence - Traction .....	37
<b>Section 2 Modes of Operation .....</b>	<b>38</b>
2.1 Normal Operation Mode .....	38
2.2 Out of Service .....	38
2.2.1 Activate Out of Service by Input .....	38
2.2.2 Activate Out of Service by Repeated Faults .....	38
2.2.3 Activate Out of Service by Runtime Limit .....	38
2.2.4 Activate Out of Service by Starts Per Minute Limit .....	39
2.2.5 Activate Out of Service by Hourly Fault Limit .....	39
2.2.6 Activate Out of Service by Door Fault Limit .....	39
2.3 Construction Mode .....	40
2.4 Machine Room Inspection Mode .....	40
2.5 Top of Car Inspection Mode .....	41
2.5.1 How to Activate .....	41
2.5.2 Door Behavior on CT Inspection .....	41
2.6 Hoistway Access Mode .....	41
2.7 Fire Phase 1 Main Recall .....	42
2.8 Fire Phase 1 Alternate Recall .....	42
2.9 Fire Phase 2 Mode .....	43
2.10 Auxiliary Power Lowering .....	43

2.11 Low Oil Mode .....	44
2.12 Motor Overheat Mode .....	44
2.13 Low Pressure .....	44
2.13.1 Overview .....	44
2.13.2 How to Activate .....	45
2.14 Jack Sync .....	45
2.14.1 Overview .....	45
2.14.2 How to Activate .....	46
2.14.2.1 Activate by Input .....	46
2.14.2.2 Activate by Day/Time .....	46
2.15 Independent Service Mode .....	46
2.15.1 Overview .....	47
2.15.2 How to Activate .....	47
<b>Section 3 Installation .....</b>	<b>48</b>
3.1 Site Preparation .....	48
3.1.1 Environmental Considerations .....	49
3.1.2 Recommended Tools, Test Equipment & Manuals .....	49
3.2 Install the Control System .....	49
3.2.1 Install the Controller Cabinet .....	49
3.2.2 Wire the Control System .....	50
3.2.2.1 Test Ground Continuity .....	50
3.2.2.2 Wire Mainline to Controller .....	50
3.2.2.3 Verify Supply Voltages .....	50
3.2.2.4 Wire Motor Leads to Pump Unit .....	50
3.2.2.5 Wire Valve Coils to Controller .....	50
3.2.2.6 Wire Temporary Pendant Station .....	50
3.3 Startup Procedure .....	51
3.3.1 Entering Construction Mode .....	51
3.3.2 Verify Pump Motor Rotation - Hydraulic .....	52
3.3.3 Attempt to Move the Car - Hydraulic .....	52
3.3.3.1 Confirm Shutoff Valves and Clearances .....	52
3.3.3.2 Confirm Valve Solenoid Operation .....	52
3.3.3.3 Valves Adjustment .....	53

3.3.3.4 Determine Desired Inspection Speed	53
3.3.3.4.1 Running on Inspection Low Speed	53
3.3.3.4.2 Running on Inspection High Speed	53
3.3.4 Adjust the Brake Voltage - Traction	53
3.3.5 Verify Drive Parameters	54
3.3.6 Motor Learn Procedure - Traction	55
3.3.6.1 Encoder Synchronization	56
3.3.6.2 Manual Encoder and Motor Direction Setup Procedure	56
3.3.7 Check Inspection Speed - Traction	57
3.4 System Components Installation and Wiring	58
3.4.1 Top of Car Box Installation and Wiring	58
3.4.2 COP Installation and Wiring	58
3.4.3 Traveler Cable Installation and Wiring	58
3.4.4 Running Car Top Inspection	58
3.4.5 Landing System Installation	59
3.4.5.1 Landing System Installation Verification	65
3.4.6 Hoistway Wiring	65
3.4.6.1 Mechanical Switches and Peripherals Wiring	65
3.4.6.1.1 Safety Circuit	65
3.4.6.1.2 Door Locks	65
3.4.6.1.3 Access Switches	65
3.4.6.2 Hall Network	65
3.4.6.2.1 Hall Network Wiring	66
3.4.6.2.2 Addressing Hall Boards	66
3.4.6.2.3 Verify Hall Network	67
3.5 Learning the Hoistway	69
3.5.1 Learn by Landing Positions	71
3.5.2 NTSD/ETSD Learn – Traction	73
3.6 Adjusting	74
3.6.1 Adjust Parameters	75
3.6.2 Adjust Slowdown Distance - Hydraulic	76
3.6.3 Adjust Number of Floors	77
3.6.4 Adjusting Inputs	78

<b>Section 4 Testing</b> .....	<b>80</b>
4.1 Testing Procedures .....	80
4.1.1 Low Oil Operation .....	80
4.1.1.1 Simulating A Low Oil Condition .....	80
4.1.1.2 Resetting Low Oil .....	82
4.1.2 Hot Oil .....	82
4.1.2.1 Simulating Hot Oil Under Normal Conditions .....	82
4.1.2.2 Resetting Hot Oil .....	83
4.1.3 Valve Pressure Relief Test .....	83
4.1.4 Normal Terminal Stopping Device (NTSD) .....	83
4.1.5 Terminal Speed Reducing Device (TSRD) – Hydraulic .....	86
4.1.6 ETSD Test .....	88
4.1.7 Unintended Motion Test .....	89
4.1.8 Overspeed Test .....	92
<b>Section 5 Troubleshooting</b> .....	<b>94</b>
5.1 Faults .....	94
5.1.1 Fault Process .....	94
5.1.2 Fault Record .....	95
5.2 Alarms .....	95
5.2.1 Alarms Overview .....	95
5.2.2 Alarm Fields .....	97
<b>Section 6 Updating Software</b> .....	<b>98</b>
6.1 Entering and exiting Bootloader mode .....	98
6.2 Preparing USB with Nexus Firmware .....	99
6.3 Flashing new applications to nodes .....	99
6.3 Bootloader LED sequence status .....	100
<b>Glossary</b> .....	<b>101</b>

# Section 1 Product Description

The Nexus™ Elevator Controller is a computer-based system that offers superior performance, flexibility, and reliability. The controller is designed for quick installation and ease of troubleshooting. It is important for elevator personnel to familiarize themselves with these manual procedures, which provide a detailed reference for controller installation. Elevator personnel should read it thoroughly before attempting to install equipment.

## 1.1 PRODUCT CODE COMPLIANCE

---

- ASME A17.1/CSA B44
- ASME A17.5/CSA B44.1

## 1.2 SPECIFICATIONS

---

### Hydraulic:

- Input Voltage: 3PH, 208-480VAC, 50/60hz
- Rated Motor Power: 3PH, 100HP@480VAC
- Rated Speed: up to 200fpm
- Max Number of Landings: 8 Landings / 16 Openings (Front & Rear)
- Max Number of Cars in Group: 4 Cars

### Traction:

- Input Voltage: 3PH, 208-600VAC, 50/60hz
- Rated Motor Power: 3PH, 40HP @ 208-230VAC / 74HP @ 380-480VAC
- Rated Speed: up to 1400fpm
- Max Number of Landings: 96 Landings / 192 Openings (Front & Rear)
- Max Number of Cars in Group: 8 Cars

### 1.2.1 STANDARD FEATURES

---

- |   |  |
|---|--|
| <ul style="list-style-type: none"> <li>• Hoistway Access Operation</li> <li>• Door Motor Protection Timer</li> <li>• Eight Landings, Sixteen Openings</li> <li>• Field Adjustable Parameters</li> <li>• Fire Service Phase I Main</li> <li>• Fire Service Phase I Alternate Return</li> <li>• Fire Service Phase II</li> <li>• Independent Service</li> <li>• Inspection Operation (Machine Room, Car Top and In-Car)</li> <li>• Programable I/O</li> </ul> | <ul style="list-style-type: none"> <li>• Motor Protection Timers</li> <li>• NEMA 1 Enclosure</li> <li>• Kuebler Ants LES02D Landing system</li> <li>• Simplex and Group operation</li> <li>• Pit flood</li> <li>• Jack recycling operation</li> <li>• Viscosity Control</li> <li>• Hot Oil</li> <li>• Low Pressure</li> <li>• Hall Lanterns</li> </ul> |
|---|--|

## 1.2.2 OPTIONAL FEATURES

---

- Attendant Service
- Code Blue Hospital Service
- Earthquake Service
- Remote Diagnostics - Vantage Connect
- Hall and Car Call Security
- Rear Doors

## 1.2.3 ENVIRONMENT

---

- 32°F/0°C to 110°F/43°C Ambient Operating Temperature
- 12,000 Feet Maximum Altitude
- 95% Maximum Non-Condensing Humidity

## 1.3 REFERENCE MATERIALS NEEDED

---

- Nexus™ Job Prints

## 1.4 ENCLOSURE LAYOUT

### 1.4.1 MACHINE ROOM ENCLOSURE LAYOUT - HYDRAULIC

Figure 1 shows the general layout of the controller enclosure.

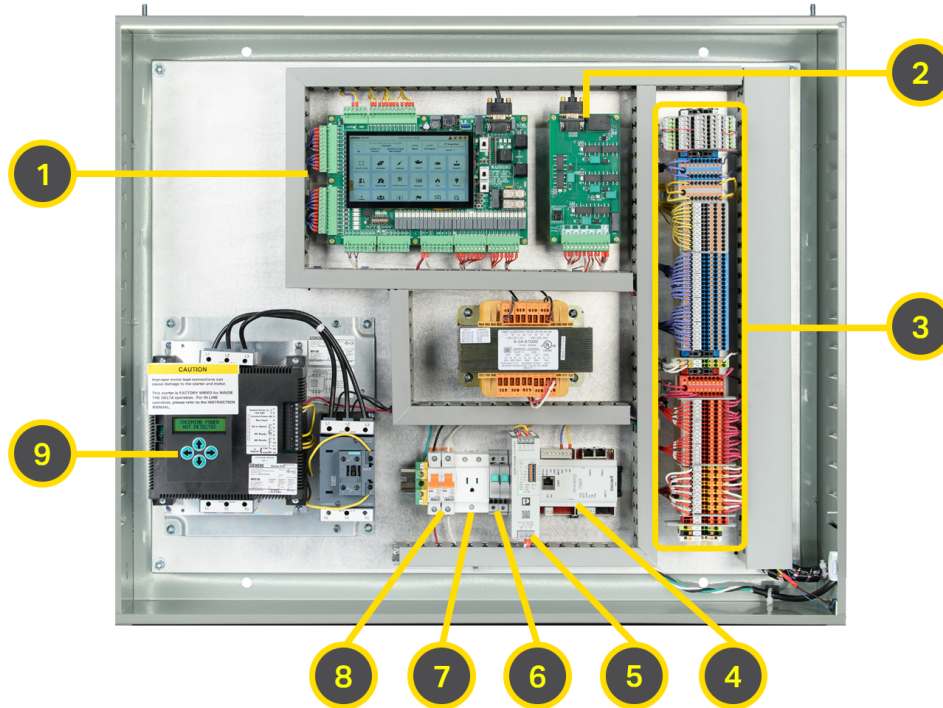

Figure 1: Machine Room (MR) Hydraulic Layout

#### LEGEND

1. Machine Room (MR) Board – NEXS-0001
2. Valve Board – NEXS-0002
3. Terminal Strip
4. Vantage Connect (Optional)
5. 24VDC Power Supply
6. Mini-breakers for Control Voltage
7. 120VAC Service Power Outlet
8. Primary-side Breaker for Control Transformer
9. Soft Start (Siemens or Sprecher & Schuh)

## 1.4.2 MACHINE ROOM ENCLOSURE LAYOUT - TRACTION

Figure 2 shows the general layout of the traction enclosure.

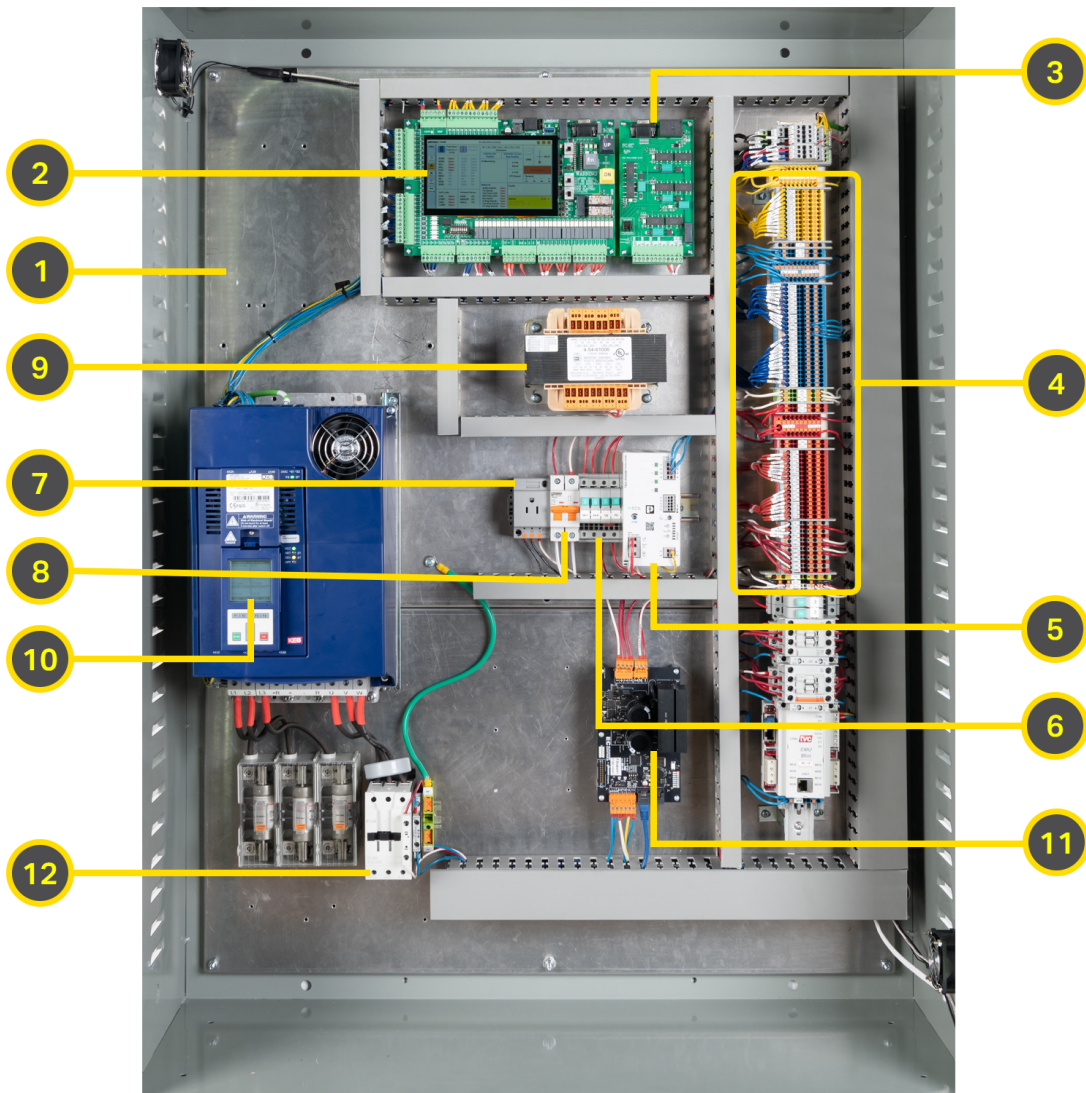

Figure 2: Machine Room (MR) Traction Layout

### LEGEND

- |  |   |
|--|---|
| 1. Hydro/Traction Backplate                  | 7. 120VAC Service Power Outlet                  |
| 2. Machine Room (MR) Board – NEXS-0001       | 8. Primary-side Breaker for Control Transformer |
| 3. Valve-Brake Relay (VBR) Board – NEXS-0002 | 9. Control Transformer                          |
| 4. Terminal Strip                            | 10. VFD (KEB F6 Drive)                          |
| 5. 24VDC Power Supply                        | 11. DC Brake (DCB) Board – NEXS-0014            |
| 6. Mini-breakers for Control Voltages        | 12. Motor Contactor                             |

### 1.4.3 CARTOP BOX LAYOUT

Figure 3 shows the cartop box layout.

#### LEGEND

1. Pre-wired Cartop Inspection Station
2. Cartop (CT) Board – NEXS-0003
3. Fan and Light Relay
4. Terminal Strip
5. Strip Light Switch

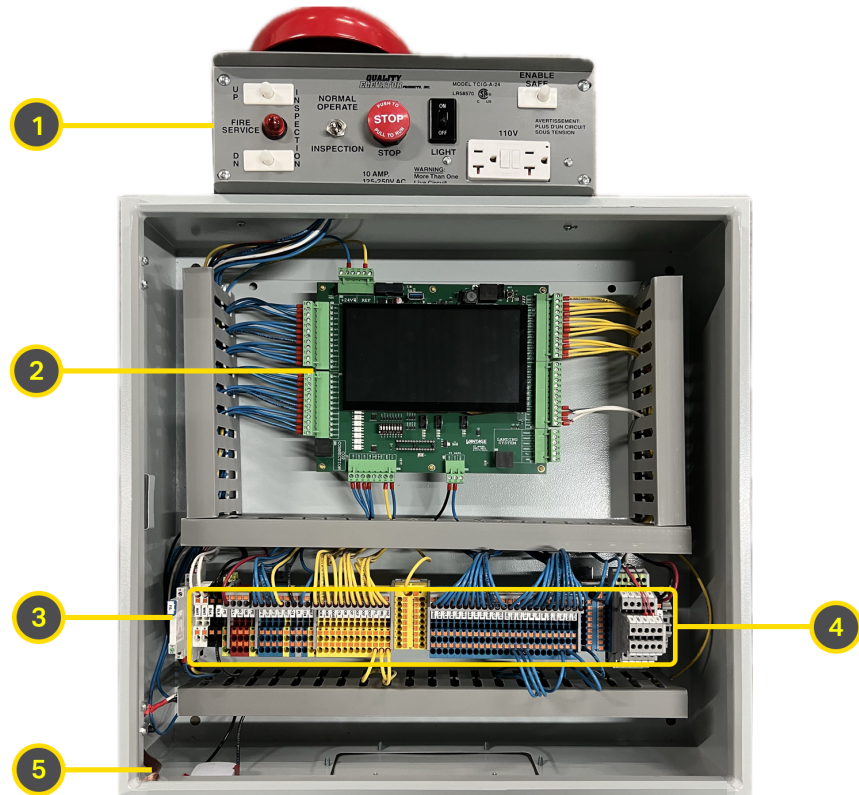

Figure 3: Cartop (CT) Box Layout – ASMB-0002

The Cartop box included with your Nexus™ controller comes pre-wired with usability in mind. The inspection station, cartop light, and CT board are conveniently connected to the color-coded terminal strip to simplify wiring, and the enclosure is well lit with a standard service light.

All connections from the controller to the car are made within the CT box. With Nexus™ technology, travelling cable wires are greatly reduced, typically only requiring the following number of travelling cable wires:

- 7 – 18AWG
- 3 – 14AWG
- 3 – 20AWG PR Shielded Pairs



This is a minimum number of wires and does not include conductors for any 3<sup>rd</sup> party devices or required spares.

Installation instructions can be found by referencing your job prints and [Section 3.4 System Components Installation and Wiring](#) of this manual.

Additional information regarding the NEXS-0003 Cartop (CT) board can be found in [Section 1.5.3. Car Top \(CT\) Board – NEXS-0003](#) of this manual.

## 1.5 CONTROLLER BOARD OVERVIEWS

The Nexus™ Controller consists of five different printed circuit boards (PCBs). The boards in their respective locations are connected to each other through multiple different CAN busses, dramatically reducing the number of wires required during installation.

The boards in their respective locations are connected to each other through a variety of CAN bus networks.

### 1.5.1 MACHINE ROOM (MR) BOARD – NEXS-0001

The Machine Room (MR) Board (shown in [Figure 4](#) and [Figure 5](#)) is installed in the Machine Room Controller Cabinet and is the central control board for the Nexus™ controller, executing main system programs.

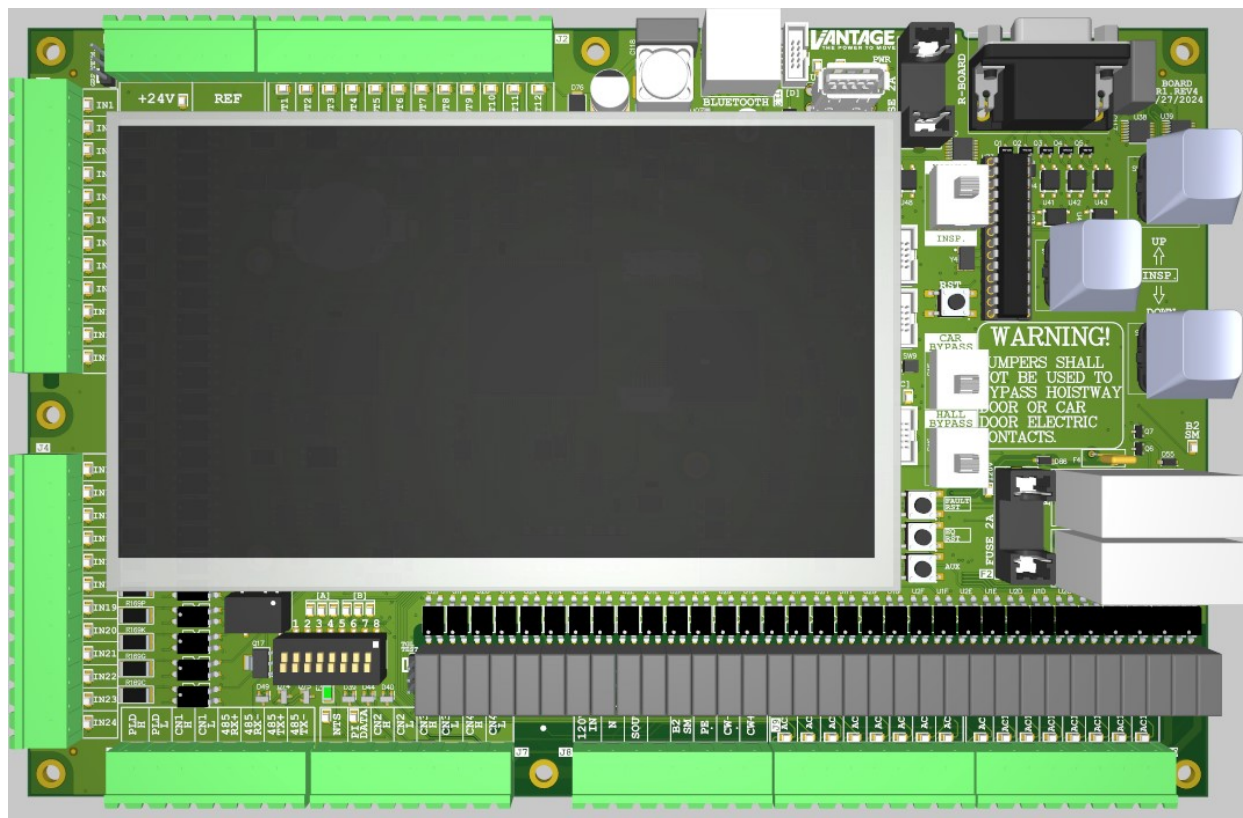

Figure 4: Machine Room (MR) Board - NEXS-0001

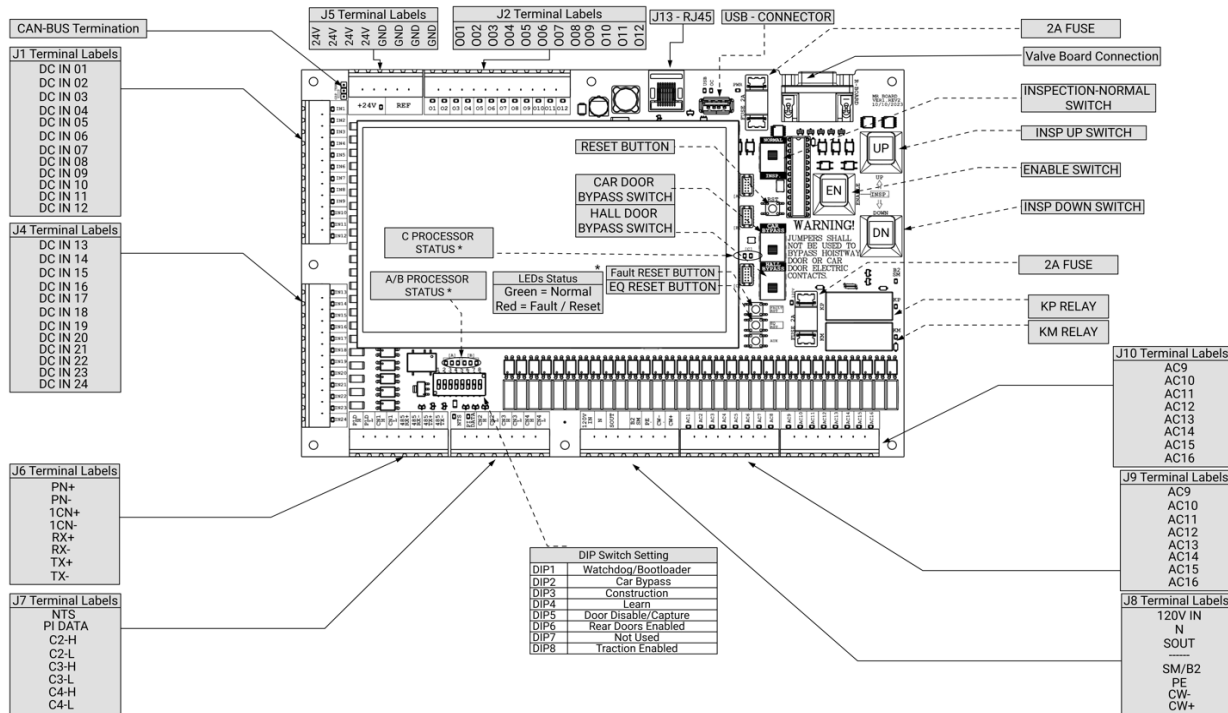

Figure 5: Machine Room (MR) Board Callouts

### DIP Switch settings:

- **DIP1:** Watchdog/bootloader
- **DIP2:** Car Bypass Mode
- **DIP3:** Construction Mode (Requires MR DIP2 ON).
- **DIP4:** Learn
- **DIP5:** Door Disabled/Capture
- **DIP6:** Rear Door Enabled
- **DIP7:** Test Mode
- **DIP8:** Traction Enabled

**KP Relay:** Safety relay controller by the Safety processor. KP relay contact is in series with KM relay and controls the output of SOUT.

**KM Relay:** Safety relay controller by the Main processor. KM relay contact is in series with KP relay and controls the output of SOUT.

### Technical Details:

Input voltages – 120VAC, 24VDC

Overcurrent protection:

- F1 – T2AL 250V Fuse
- F2 – T2AL 250V Fuse

Output voltages – 120VAC

## 1.5.2 VALVE-BRAKE RELAY (VBR) BOARD – NEXS-0002

Shown in **Figure 6** and **Figure 7**, the VBV Board is installed in the Machine Room Controller Cabinet next to the Machine Room Board and provides output to the 120VAC valve coils.

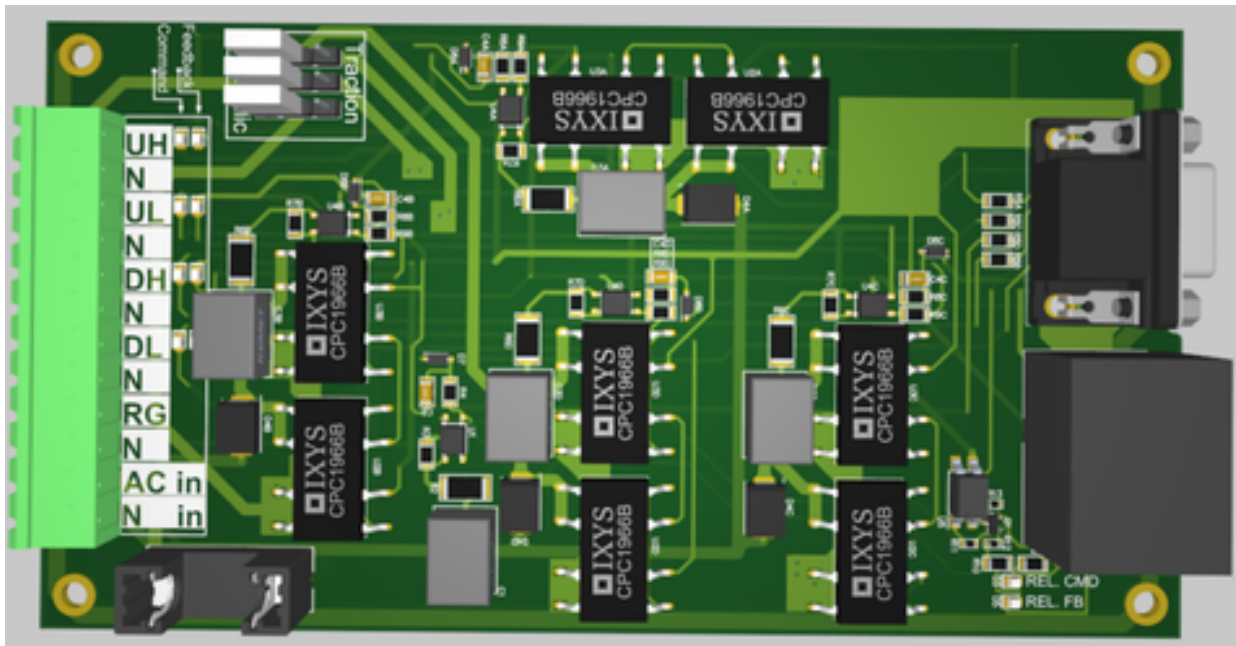

Figure 6: Valve Board - NEXS-0002

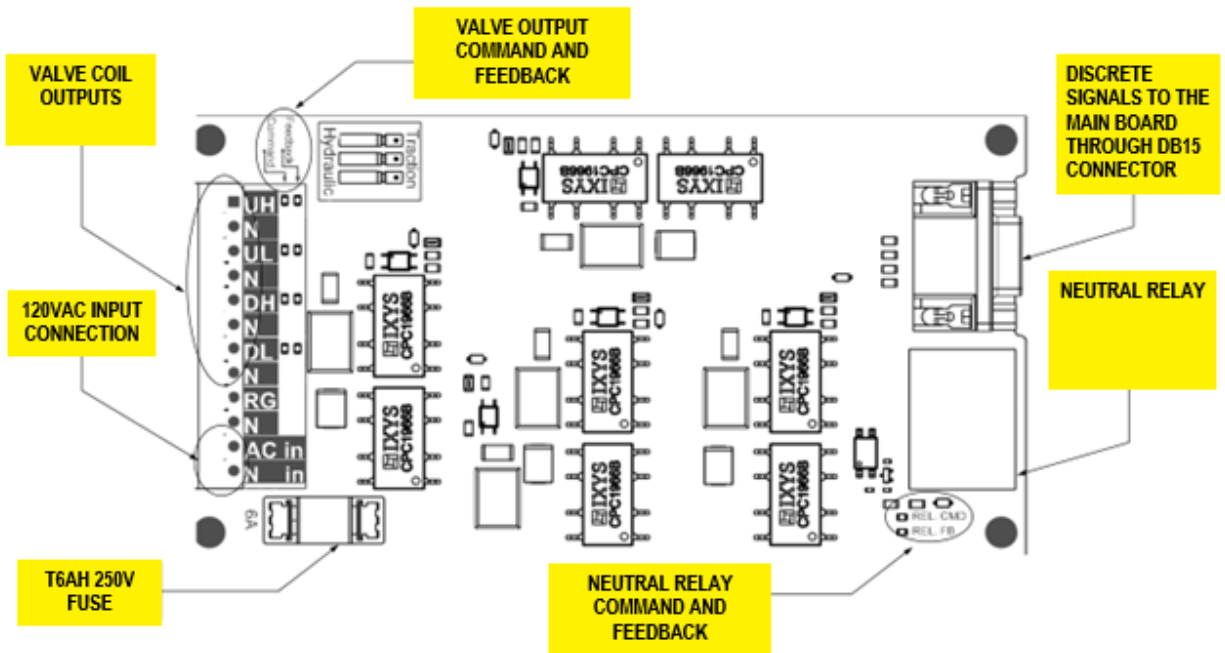

Figure 7: Valve Board Callouts

## Description:

The NEXS-0002 Valve Board is controlled by the NEXS-0001 MR Board through a DB15 cable and receives 120VAC power from the SOUT output of the MR board. 120VAC power is removed from this board if the KP or KM are opened due to the detection of a fault condition by either the Safety or Main Processors on the MR board. The Neutral relay is also deactivated on faults by either the Safety or main processors to remove the Neutral connection of Valves.

When set to Traction, the board is powered directly by 120VAC and controls the rope brake coil.

LEDs on the board provide visual feedback on the state of the Neutral relay and the valve outputs. Command (CMD) LEDs are ON when a signal is issued from the MR to engage the Neutral relay or a valve output. Feedback (FB) LEDs are ON when the sensing circuit detects the output signal and feedback is provided back to the MR.



Neutral and 120V input must be connected for feedback to work. Valve feedback LEDs only detect the activity of the output and not the presence of a Valve coil.

The MP board controls four solid state relays on the Valve board to energize the valve coils during operation. These relays are rated at 250VAC 10A.

The sequence of operation can be found in [Section 1.7 Sequence of Operation](#) of this manual.

## Technical Details:

Input voltage – 120VAC

Overcurrent protection – T6AH 250V fuse

Output voltage – 120VAC

## 1.5.3. CAR TOP (CT) BOARD – NEXS-0003

Shown in **Figure 8** and **Figure 9**, the CT board is installed in the car top box mounted on top of the elevator car and captures inputs from the top-of-car safety devices as well as the landing system connections. Inputs 1-8 on the CT are reserved for safety functions. The remaining inputs and outputs are programmable. All inputs on the CT board are 24VDC.

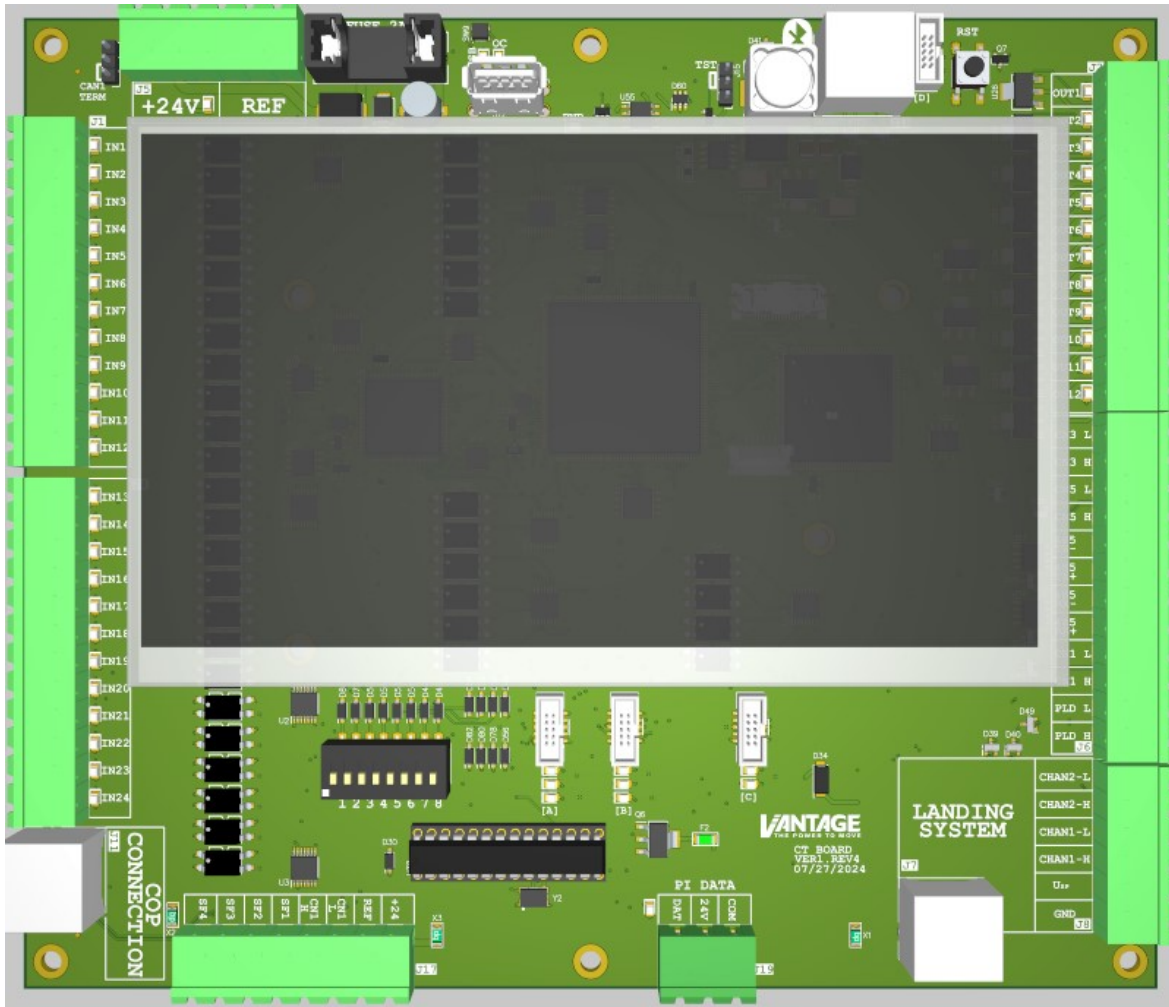

Figure 8: Car Top Board - NEXS-0003

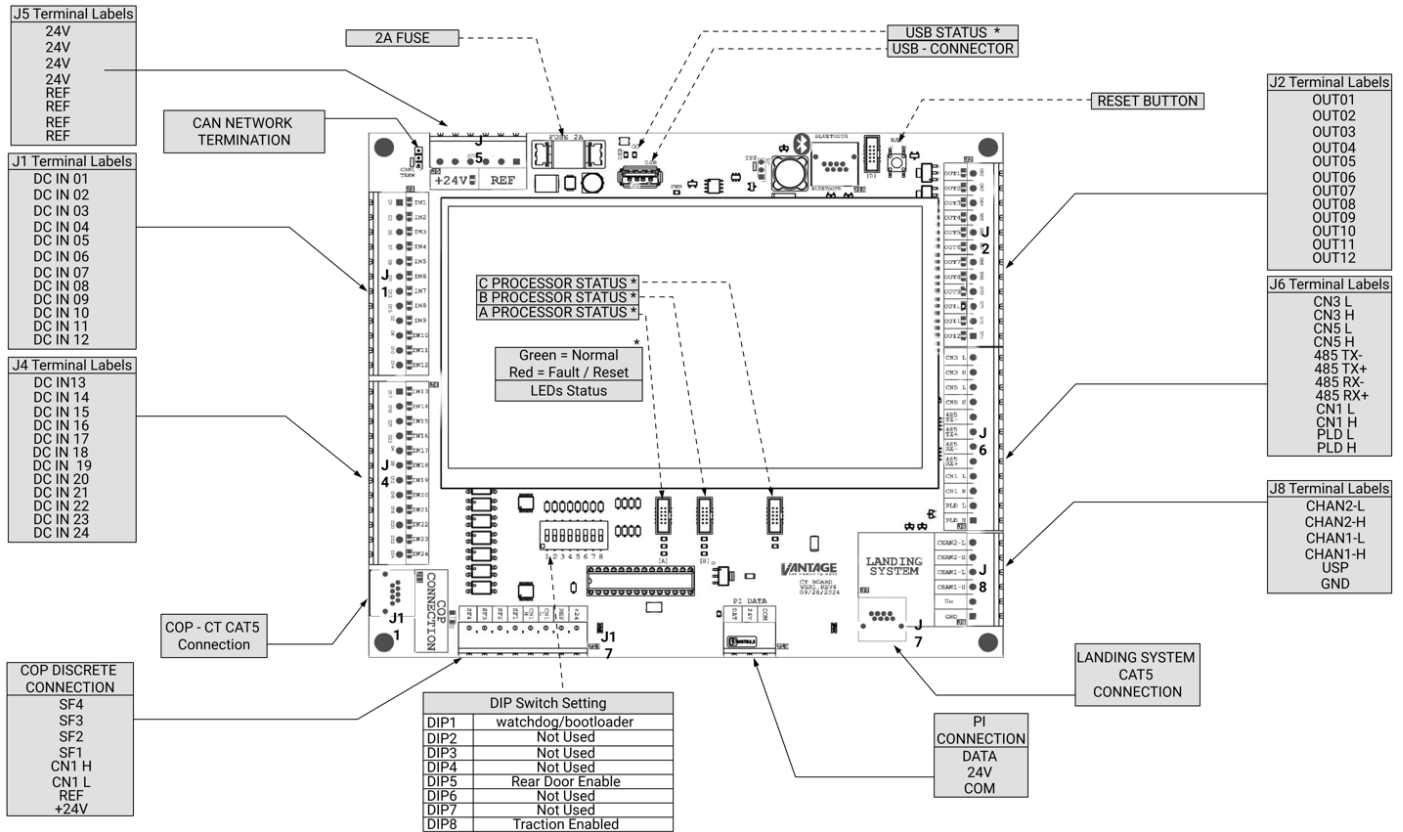

Figure 9: Car Top Board Callouts

### DIP switches for CT Board:

- **DIP1:** Watchdog/bootloader
- **DIP2:** UNUSED
- **DIP3:** UNUSED
- **DIP4:** UNUSED
- **DIP5:** UNUSED
- **DIP6:** Rear Door Enabled
- **DIP7:** UNUSED
- **DIP8:** Traction Enabled

## 1.5.4 CAR OPERATING PANEL (COP)/EXPANSION (I/O)/RISER (GROUP) BOARD – NEXS-0004

The NEXS-0004 board has multiple functionalities such as the COP board, Expansion board, and Riser board. These functionalities are determined based on the on-board DIP switch settings. As a COP (DIP switches 1-8 OFF) it captures the safety devices in the car. Inputs 1-4 are fixed safety inputs while the rest of the Inputs and Outputs are programmable. The COP board can be connected to the CT board via the RJ45 or discretely. All IO points on this board are 24VDC.

As an Expansion board, assigned when Address DIPs 1-5 are set as shown in **Table 1**, this board can be used to add more programmable inputs and outputs to the system. Expansion boards are broken into Main and Secondary. When set to Main, denoted as [M] in the table below, the expansion board is connected to the car network (CAN1) along with the MR/CT/COP. Secondary boards, denoted as [S] in the table below, are connected to the Main expansion board. The Nexus™ system supports five Main boards with three secondary boards each for a total of 20 expansion boards.

A Riser board, required for multicar elevator banks, is assigned when DIP8 is ON plus the address DIPs, is used for communicating with Hall nodes and receiving discrete group inputs and outputs.

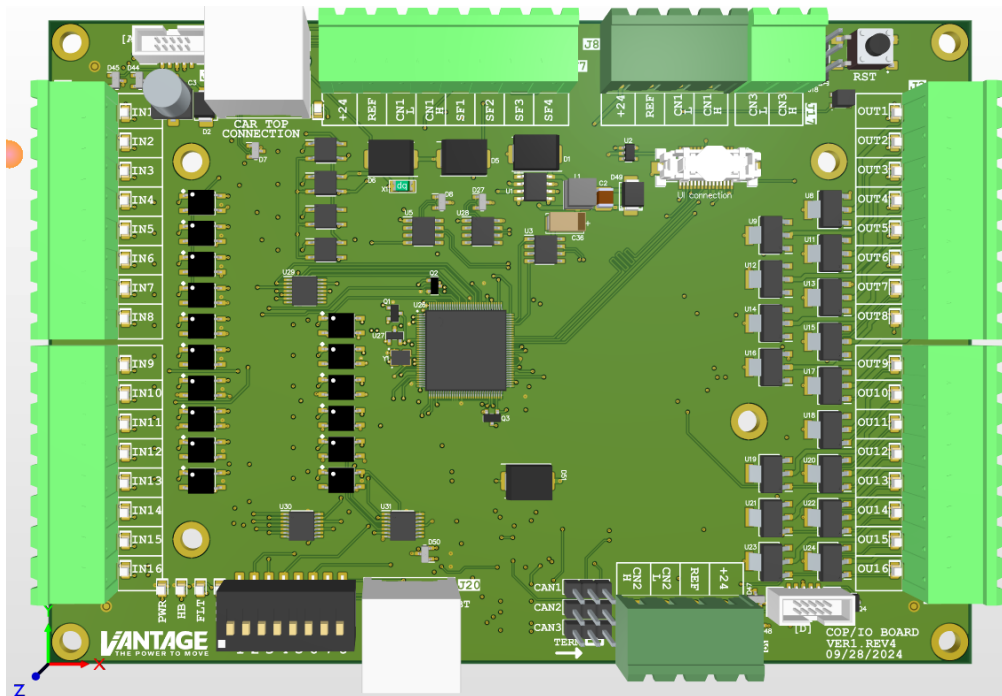

Figure 10: COP/IO/Riser Board - NEXS-0004

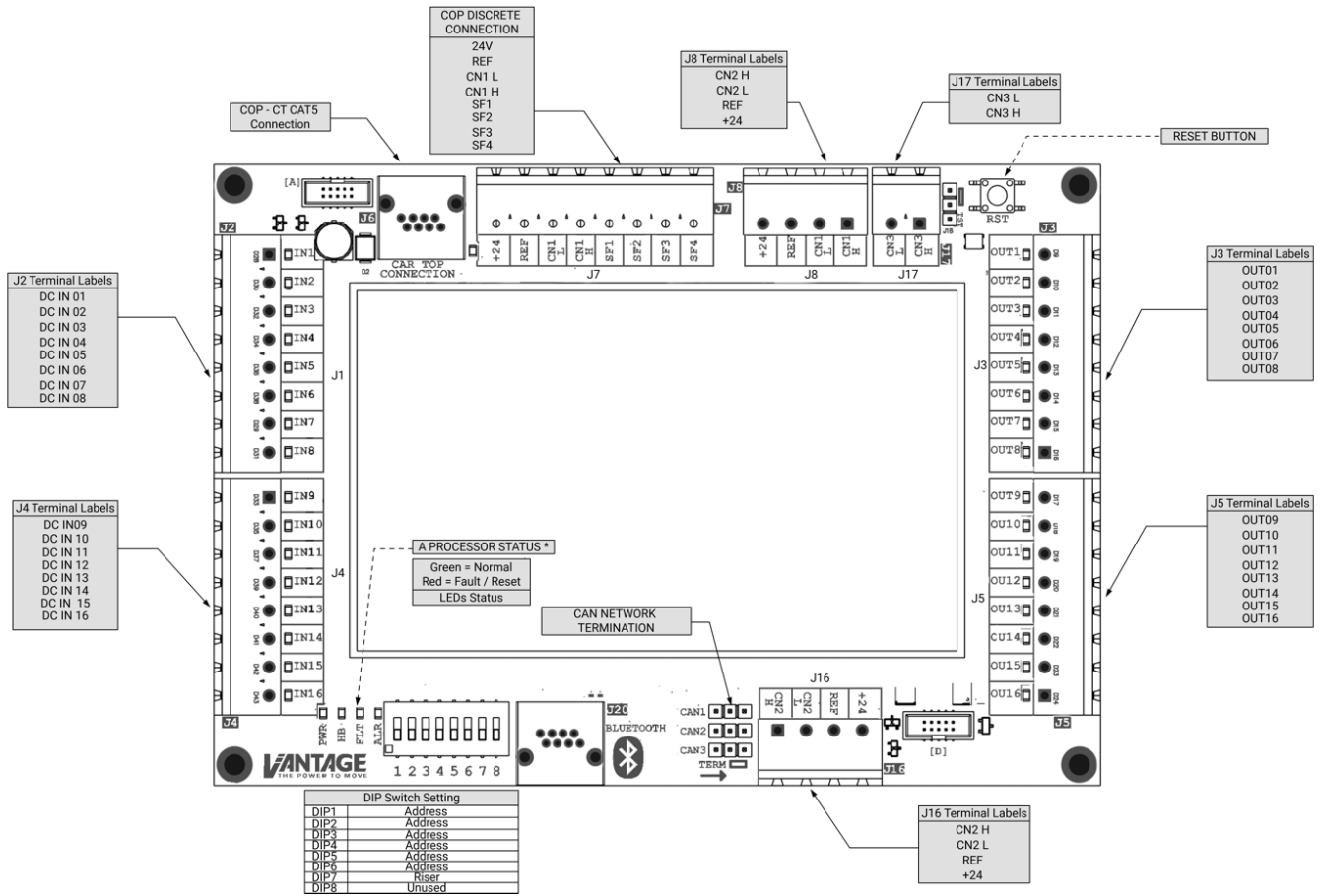

Figure 11: COP/IO Board Callouts

## DIP switch settings for Car Operating Panel:

*Table 1: COP/IO Board DIP Settings*

Name	DIP1	DIP2	DIP3	DIP4	DIP5	DIP6	DIP7	DIP8
COP	OFF	OFF	OFF	OFF	OFF	OFF	OFF	X
Expansion 1 [M]	ON	OFF	OFF	OFF	OFF	OFF	OFF	X
Expansion 2 [S]	OFF	ON	OFF	OFF	OFF	OFF	OFF	X
Expansion 3 [S]	ON	ON	OFF	OFF	OFF	OFF	OFF	X
Expansion 4 [S]	OFF	OFF	ON	OFF	OFF	OFF	OFF	X
Expansion 5 [M]	ON	OFF	ON	OFF	OFF	OFF	OFF	X
Expansion 6 [S]	OFF	ON	ON	OFF	OFF	OFF	OFF	X
Expansion 7 [S]	ON	ON	ON	OFF	OFF	OFF	OFF	X
Expansion 8 [S]	OFF	OFF	OFF	ON	OFF	OFF	OFF	X
Expansion 9 [M]	ON	OFF	OFF	ON	OFF	OFF	OFF	X
Expansion 10 [S]	OFF	ON	OFF	ON	OFF	OFF	OFF	X
Expansion 11 [S]	ON	ON	OFF	ON	OFF	OFF	OFF	X
Expansion 12 [S]	OFF	OFF	ON	ON	OFF	OFF	OFF	X
Expansion 13 [M]	ON	OFF	ON	ON	OFF	OFF	OFF	X
Expansion 14 [S]	OFF	ON	ON	ON	OFF	OFF	OFF	X
Expansion 15 [S]	ON	ON	ON	ON	OFF	OFF	OFF	X
Expansion 16 [S]	OFF	OFF	OFF	OFF	ON	OFF	OFF	X
Expansion 17 [M]	ON	OFF	OFF	OFF	ON	OFF	OFF	X
Expansion 18 [S]	OFF	ON	OFF	OFF	ON	OFF	OFF	X
Expansion 19 [S]	ON	ON	OFF	OFF	ON	OFF	OFF	X
Expansion 20 [S]	OFF	OFF	ON	OFF	ON	OFF	OFF	X
Expansion 21 [M](Future)	ON	OFF	ON	OFF	ON	OFF	OFF	X
Expansion 22 [S](Future)	OFF	ON	ON	OFF	ON	OFF	OFF	X
Expansion 23 [S](Future)	ON	ON	ON	OFF	ON	OFF	OFF	X
Expansion 24 [S](Future)	OFF	OFF	OFF	ON	ON	OFF	OFF	X
Riser 1	ON	OFF	OFF	OFF	OFF	OFF	ON	X
Riser 2	OFF	ON	OFF	OFF	OFF	OFF	ON	X
Riser 3	ON	ON	OFF	OFF	OFF	OFF	ON	X
Riser 4	OFF	OFF	ON	OFF	OFF	OFF	ON	X
Test	ON	ON	ON	ON	ON	ON	ON	X

The above DIP switch addressing allows configuring the board as a COP, Expansion Board, or Riser Board. The DIP functionality is as follows:

- **DIP1-7:** Configures as COP or expansion board or Riser (DIP7 only on for Risers and test mode).
- **DIP8:** When ON disables watchdog. Otherwise, watchdog is enabled.

### 1.5.5 DC BRAKE (DCB) BOARD – NEXS-0014

The DCB board communicates serially with the MR board and converts AC input voltage to DC output voltage that controls the brake coil. Users can use the UI on the MR board to adjust the output voltage and various other timers. The status of the DCB board can also be viewed via the Status menu on the UI.

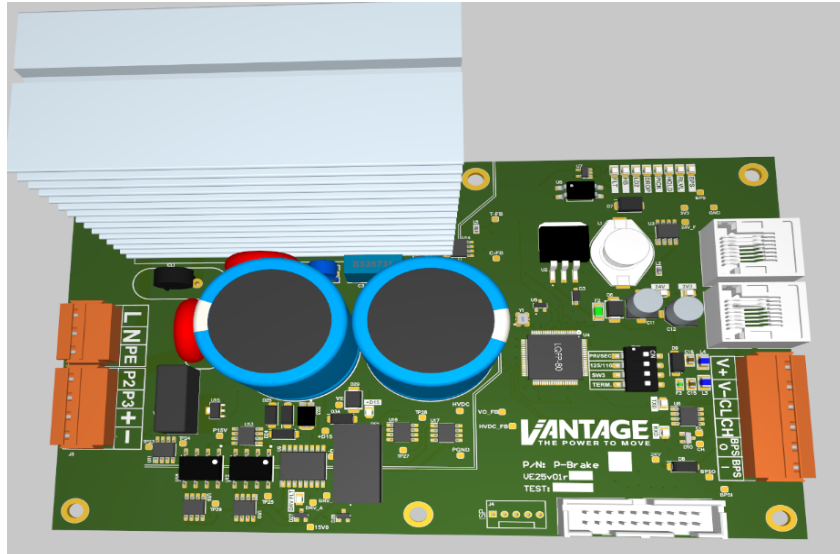

Figure 12: DC Brake Board - NEXS-0014

#### Technical Details:

- Input AC Voltage: 120VAC or 240VAC
- Input Current Max: 10A
- Input DC Voltage: 24VDC
- Output Voltage: 0-300VDC
- Output current Max: 10A
- Interface: CAN Bus
- DIP Switches: 4- position
  - Pri/Sec : Sets the brake as primary or secondary brake control
  - 125/116 : Changes the CAN Baud rate
  - Spare: for future use
  - Term: sets CAN termination

#### DC Brake Board Connectors:

- RJ45: V+,V-,CH, CL – Used to daisy chain DC brake boards. Both Ports are the same.
- J2 6pin:
  - V+: 24VDC Input
  - V-: 24v Reference
  - CL: CAN Low
  - CH: CAN High
  - BPSO: Brake Pick Switch Out
  - BPSI: Brake Pick Switch In

- J1 3Pin:
  - L : Input AC Voltage
  - N: Neutral
  - PE: Earth Ground
- J3 4Pin:
  - P2: Brake contactor contact (Not used, Jumped to P3 on Nexus)
  - P3 : Brake contactor contact (Not Used, Jumped to P2 on Nexus)
  - + : Brake Coil
  - - : Brake Coil

## **The DC Brake board has several LED status indicators:**

- BPS LED - AMBER
  - SOLID ON = BPS Feedback
- Heartbeat LED - GREEN
  - FLASHING = Healthy processor
  - OFF = Processor OFF
- FLT LED - RED
  - ON = Active Fault
- 24V LED - GREEN
  - ON = board has 24vdc power
- HVDC LED – GREEN
  - ON = High Voltage Capacitor Charged
- PICK LED - GREEN
  - ON = Pick Voltage
- RLVL LED - GREEN
  - ON = Releveling Voltage
- HOLD LED - GREEN
  - ON = Hold Voltage
- DROP LED -GREEN
  - ON = Drop Command
- TXD/RXD LEDs – BLUE
  - ON= Communication Active

### 1.5.5 HALL BOARD (HB) – NEXS-0005

Hall boards are small devices that provide two 24VDC inputs and two 0VDC sinking outputs, for hall calls and arrival lanterns. The boards can be connected using the 4-pin connector or via the RJ45 for power and communication. The Hall board is shown in **Figure 13**.

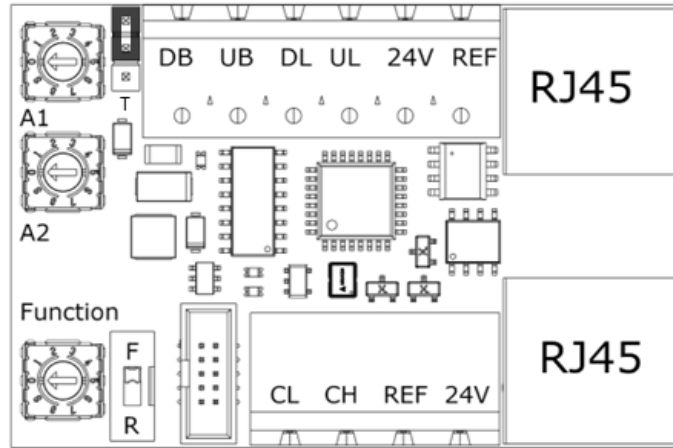

Figure 13: Hall Board - NEXS-0005

#### 1.5.5.1 SIMPLEX

Hall lanterns connect to MR board CAN3 when present and are daisy chained. All other Hall functionality (Hall calls, Swing, Medical, etc.) are connected to the MR board CAN4.

#### 1.5.5.2 GROUP

Hall Lanterns connect to MR board CAN3 when present, and are daisy chained. If a riser board is present, it communicates with all the cars and connects with the CAN4 group network of the MR board.

All other Hall functionality (Hall calls, Swing, Medical, etc.) are connected to CAN2 or 3 of the riser board.



Termination is vital when CAN is used and must be set based on the job configuration. The first and last node of each network chain must be terminated.



MR CAN1, 2 and 3 are automatically terminated on the MR board, and is considered the first node. Termination of the last node is accomplished by locating the pin jumper (T) across the two pins closest to the edge of the board. **Figure 11** shows a representation of the NEXS-0005 with the T jumper in the terminated position.

Each Hall board is uniquely identified using three rotary switches and a single DIP switch (Which designates Front or Rear opening). Multiple boards can be daisy chained together on a CAN network.

## 1.5.5.3 INPUTS

---

The board has two 24 VDC inputs intended to connect to user-facing buttons in the hallway:

- Up Button (UB)
- Down Button (DB)

## 1.5.5.4 OUTPUTS

---

The board has two 0VDC sinking outputs intended to light up the user-facing lanterns or buttons in the hallway:

- Up Lantern/Light (UL)
- Down Lantern/Light (DL)

## 1.5.5.5 FUNCTIONS AND ADDRESS SETTINGS

---

The board has three 10-position rotary switches, and one single DIP switch. These switches are used to configure and uniquely identify the board.

- Function (Func) switch: Sets the desired function of the board. See [Section 3.4.6.2.2 Addressing Hall Boards](#) for set up instructions.
- Landing 1 (A1) switch: Sets the 10s place of the landing number (10, 20, 30...).
- Landing 2 (A2) switch: Sets the 1s place of the landing number (01, 02, 03...).
- Door Side DIP Switch: Sets the opening to Front (F) or Rear (R).

## 1.5.5.6 LED INDICATORS

---

The board also has three LEDs to provide feedback about the operating state of the board:

- Fault LED (Red indicates an active fault)
- Heartbeat LED (Blinking Green ON if actively communicating with the Nexus™ Controller, OFF if not)
- Power LED (Green ON if the board has power, OFF if not)

## 1.5.5.7 SELF-TEST MODE

---

This mode can be used to manually validate the hall board hardware. To enter test mode, set each rotary switch to "9". In test mode the board behaves as follows:

- Activate UB input by connecting 24VDC to it. This will activate UL output.
- Activate DB input by connecting 24VDC to it. This will activate DL output.
- FLT\_LED toggles on active CAN communication.

# CONTROLLER NETWORK BLOCK DIAGRAM

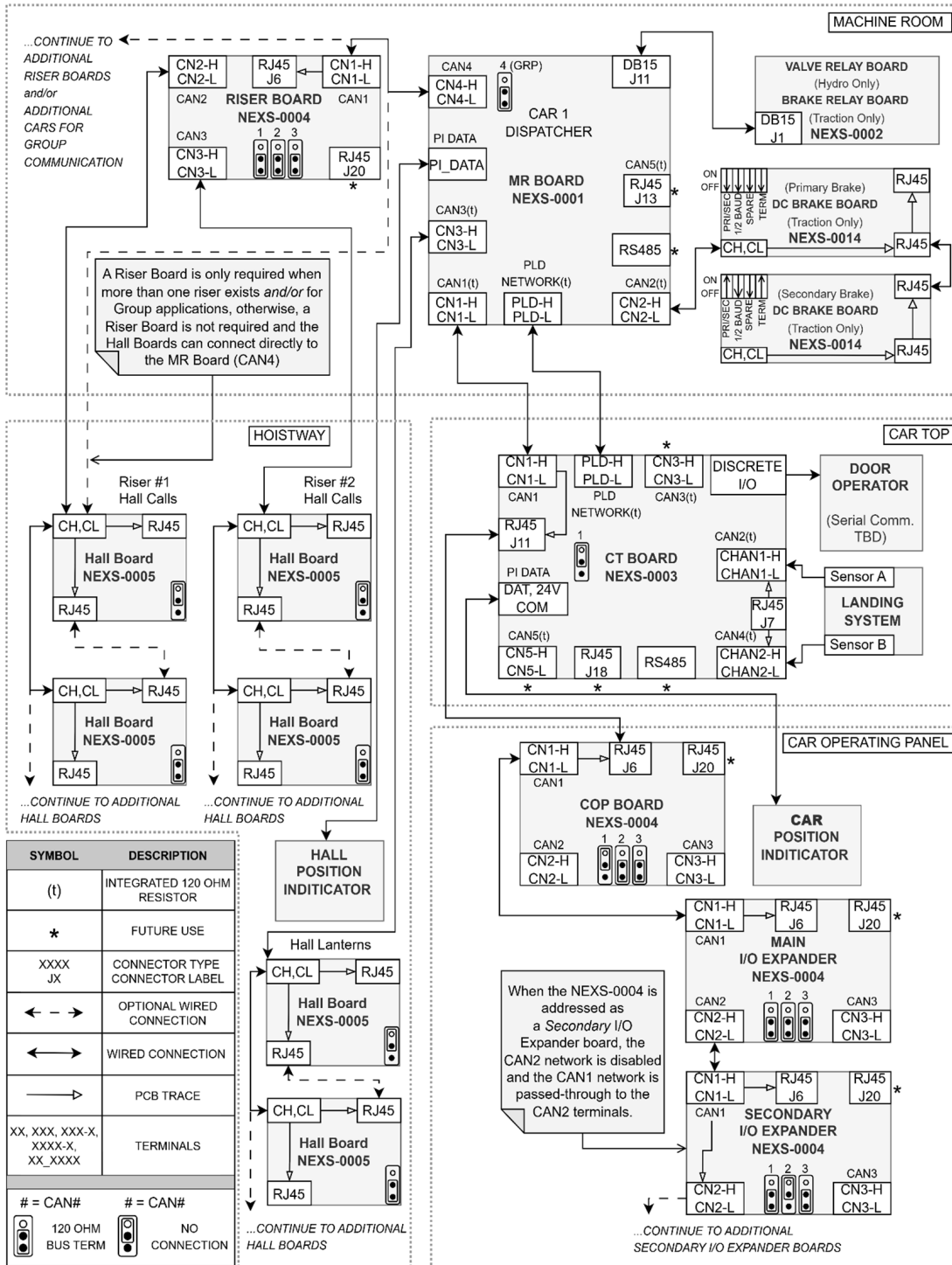

## 1.6 USER INTERFACE

The Nexus™ User Interface is designed to provide immediate information on a 7" display that allows for ease of troubleshooting and adjustments.

### 1.6.1 HOME SCREEN

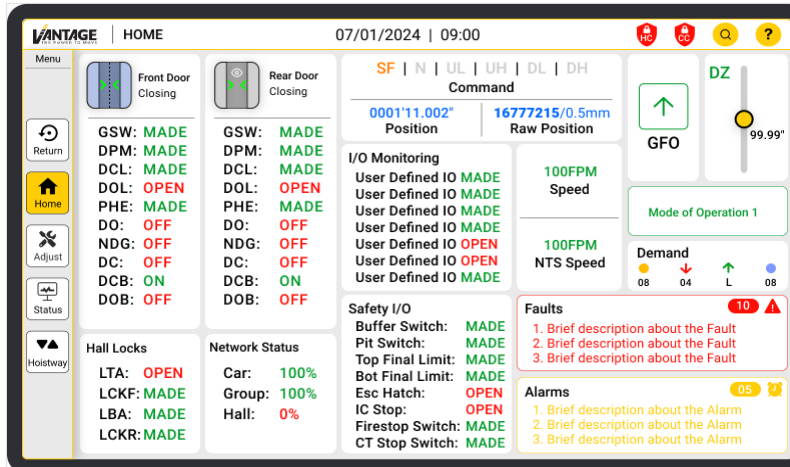

Figure 15: Home Screen. (Data shown for Illustrative Purposes only)

The **Home** screen of the Nexus™ Controller provides a quick glance at the state of the elevator and critical components that enables a quick diagnosis of elevator status.

#### 1.6.1.1 CAR DOOR STATUS

Displays front and rear (if applicable) door status as well as the associated inputs and outputs.

The abbreviations shown here are for the following functions, each of which displays status as OPEN or MADE for inputs and ON or OFF for outputs:

- **GSW:** Gateswitch
- **DPM:** Door Position Monitoring
- **DCL:** Door Close Limit
- **DOL:** Door Open Limit
- **PHE:** Photoeye
- **DO:** Door Open
- **NDG:** Nudge
- **DC:** Door Close
- **DCB:** Door Close Button
- **DOB:** Door Open Button

### 1.6.1.2 HALL DOOR STATUS

Displays the state of the Hall locks.

- **LTA:** Lock Top Access
- **LCKF:** Locks Front
- **LBA:** Lock Bottom Access
- **LCKR:** Locks Rear

### 1.6.1.3 NETWORK STATUS

Shows the health of the networks currently connected.

- **Car:** Represents the Car Net (CAN1) that the main boards communicate on.
- **Group:** Represents the Group network (CAN4) on the Machine room.
- **Hall:** Represents communication with Hall boards.

### 1.6.1.4 MOTION STATE:

Gives a quick look at which stage of the run sequence the controller is in, position, and speed.



Figure 16: Speed position and feedback. (Data shown for illustrative purposes only)

The following signals are highlighted when active and greyed out when inactive.

- **SF:** Safety Relay
- **N:** Valve Neutral Relay
- **UL:** Up Leveling Valve
- **UH:** Up High Valve
- **DL:** Down Leveling Valve
- **DH:** Down High Valve
- **Raw Position:** reading from the landing system in .5mm increments.
- **Position:** Converted Raw Position to feet and inches.
- **Speed:** Speed feedback from Channel 1 from the landing system (FPM).
- **NTS Speed:** Speed feedback from Channel 2 from the landing system (FPM).

## 1.6.1.5 INPUT AND OUTPUT (I/O) MONITORING:

Safety signals are represented in the Safety I/O section, which provides feedback when the safety contact is **MADE** or **OPEN**.

Safety I/O		I/O Monitoring	
Buffer Switch:	Made	User Defined IO	Made
Pit Switch:	Made	User Defined IO	Made
Top Final Limit:	Made	User Defined IO	Made
Bot Final Limit:	Made	User Defined IO	Made
Esc Hatch:	Open	User Defined IO	Made
IC Stop:	Open	User Defined IO	Open
Firestop Switch:	Made	User Defined IO	Open
CT Stop Switch:	Made	User Defined IO	Made

Figure 17: I/O Monitoring. (Data for illustrative purposes only)

Manually select I/O to monitor in the I/O Monitoring section.

To select an I/O to add to the **Home** screen, go to **Status > I/O** and select the board and the Input or Output to monitor by touching the radio button next to the desired choice.

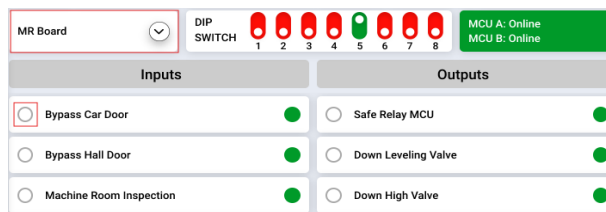

Figure 18: I/O Status Screen

## 1.6.1.6 POSITION INDICATOR (PI) AND DOOR ZONE (DZ)

The position indicator and the door zone provide the location of the elevator relative to the floor and the distance from that floor. The arrow above the PI, 'GFO' in this example, represents the direction of car travel.



Figure 19: PI and DZ. (Data for illustrative purposes only)

The DZ icon appears when the car is within the 6" door zone of the landing. The vertical bar represents the location of the car relative to the 6" door zone along with the distance away from the center of the door zone for that floor.

The **Mode of Operation** displays the current mode of system operation.

Demand displays the current and upcoming demand for this elevator.

### 1.6.1.6.1 HOISTWAY VIEW

The hoistway view is used to enter Car calls and Hall calls into the system.

From the **Home** screen, touch the Hoistway icon on the navigation bar to enter the Hoistway view.

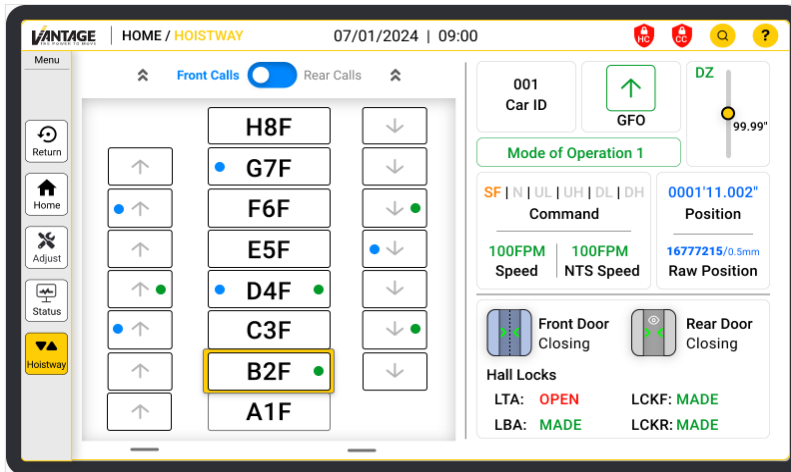

Figure 20: Hoistway View Screen. (Data shown for illustrative purposes only)

This view allows entry of hall calls by touching the UP/DOWN arrows or Car Calls by selecting the desired floor. The Front/Rear slider allows entry of the desired side for door opening, latched front calls are represented by blue dots and rear calls are represented by green dots. This view provides valuable information regarding the elevator’s command, speed, position and door state so it is not necessary to navigate back and forth. Selecting the **Home** icon on the left of the screen returns to the **Home** screen.

### 1.6.1.6.2 ADJUST SCREEN

All the options to make changes to the operation of the controller are placed in the Adjust tab and are broken into clearly labeled categories to allow for ease of navigation.

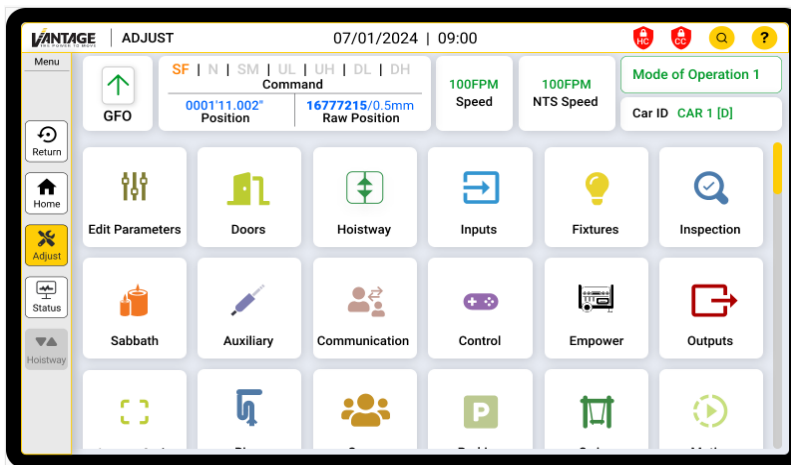

Figure 21: Adjust Screen. (Data shown for illustrative purposes only)

Touching any of the icons brings up category specific options and parameters to adjust. Use **Edit Parameters** to access all the system parameters directly and make changes without navigating to different locations.

## 1.6.1.6.3 STATUS SCREEN

The status screen allows monitoring of different aspects of the controller based on the chosen category.

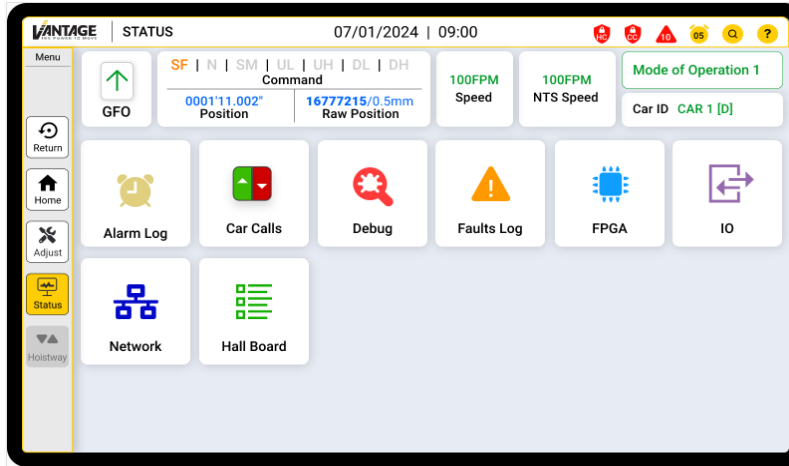

Figure 22: Adjust Screen. (Data shown for illustrative purposes only)

Alarm and Fault logs provide the user with a list of events that occurred with date and time stamps.

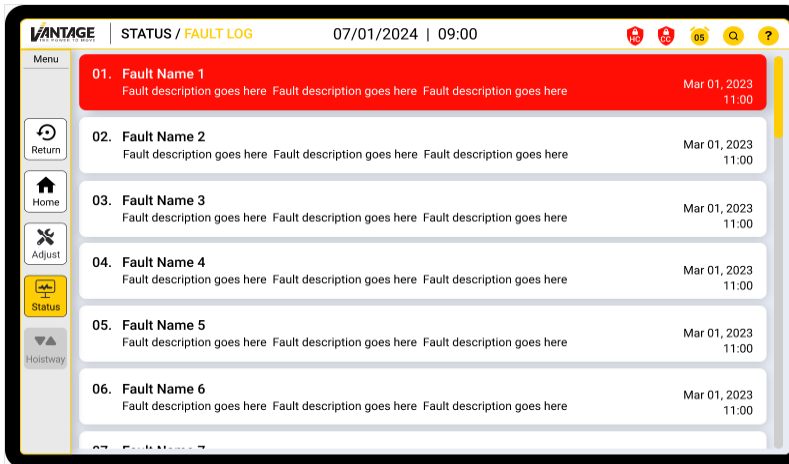

Figure 23: Fault Log. (Example Screen)

Selecting any fault brings up a window with a Description, troubleshooting steps, and the state of the elevator when the event occurred.

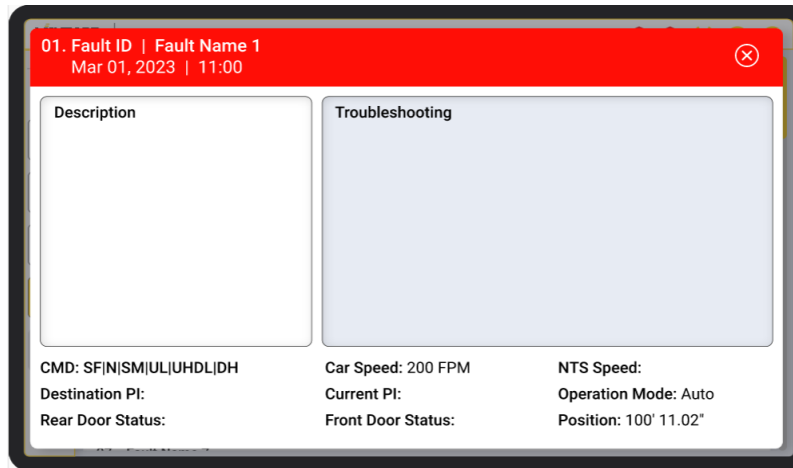

Figure 24: Fault Description. (Example Screen)

## 1.7 SEQUENCE OF OPERATION

The following sections describe the automatic run sequence of normal operation.

### 1.7.1 CAR MOVING UP RUN SEQUENCE - HYDRAULIC

1. At the start of the run, the car is stationary.
  - a. The KP Relay on the MR board is Inactive (LED off).
  - b. The KM Relay on the MR board LED is Inactive (LED off).
  - c. The Neutral Relay on the valve board is Inactive (Command and Feedback LEDs off).
  - d. The Start Motor output is Inactive (LED Off).
  - e. All Valve(s) are Inactive (Command and Feedback LEDs off).
2. The Safe Relay is picked after Parameter 16-775 (Safe Relay Pick Delay) elapses.
  - a. The KP Relay is Active (LED on).
  - b. The KM Relay LED is Active (LED on).
  - c. The Neutral Relay is Inactive (Command and Feedback LEDs off).
  - d. The Start Motor output is Inactive (LED off).
  - e. All Valve(s) outputs are Inactive (Command and Feedback LEDs off).
3. The Neutral Relay is picked after Parameter 16-774 (Neutral Relay Pick Delay) elapses.
  - a. The KP Relay is Active (LED on).
  - b. The KM Relay LED is Active (LED on).
  - c. The Neutral Relay on the valve board is Active (Command and Feedback LEDs are on).
  - d. The Start Motor output is Inactive (LED off).
  - e. All Valve(s) outputs are Inactive (Command and Feedback LEDs off).
4. The Start Motor output activates. The Up to Speed delay (Parameter 16-776) and Up to Speed input are monitored before proceeding with valve activation.
  - a. The KP Relay is Active (LED on).
  - b. The KM Relay LED is Active (LED on).
  - c. The Neutral Relay is Active (Command and Feedback LEDs on).

- d. The Start Motor output is Active (LED on).
- e. All Valve(s) outputs are Inactive (Command and Feedback LEDs off).
5. The Valve(s) activate.
  - a. The KP Relay is Active (LED on).
  - b. The KM Relay LED is Active (LED on).
  - c. The Neutral Relay is Active (Command and Feedback LEDs on).
  - d. The Start Motor output is Active (LED on).
  - e. The UP Valve(s) are Active (Command and Feedback LEDs on).
  - f. The DOWN Valve(s) are Inactive (Command feedback LEDs off).
  - g. The car moves.
6. Once the slowdown point is reached, the UH valve is Inactive (Command and Feedback LEDs off).
7. Once the car levels to door zone, the UL valve is Inactive (Command and Feedback LEDs off).
8. The Start Motor output deactivates after Parameter 16-777 (Pump Off Delay) elapses. The LED turns off.
9. The Neutral Relay drops after Parameter 16-779 (Neutral Relay Drop Delay) elapses. The Command and Feedback LEDs turn off.
10. The Safe Relays drops after Parameter 16-778 (Safe Relay Drop Delay) elapses.
  - a. The KP Relay LED turns off.
  - b. The KM Relay LED turns off.

## 1.7.2 CAR MOVING DOWN RUN SEQUENCE - HYDRAULIC

1. At the start of the run, the car is stationary.
  - a. The KP Relay is Inactive (LED off).
  - b. The KM Relay LED is Inactive (LED off).
  - c. The Neutral Relay is Inactive (Command and Feedback LEDs off).
  - d. The Start Motor output is Inactive (LED off).
  - e. All Valve(s) are Inactive (Command and Feedback LEDs off).
2. The Safe Relay is picked after Parameter 16-775 (Safe Relay Pick Delay) elapses.
  - a. The KP Relay is Active (LED on).
  - b. The KM Relay LED is Active (LED on).
  - c. The Neutral Relay is Inactive (Command and Feedback LEDs off).
  - d. The Start Motor output is Inactive (LED off).
  - e. All Valve(s) are Inactive (Command and Feedback LEDs off).
3. The Neutral Relay is picked after Parameter 16-774 (Neutral Relay Pick Delay) elapses.
  - a. The KP Relay is Active (LED on).
  - b. The KM Relay LED is Active (LED on).
  - c. The Neutral Relay is Active (Command and Feedback LEDs on).
  - d. The Start Motor output is Inactive (LED off).
  - e. All Valve(s) are Inactive (Command and Feedback LEDs off).
4. The Valve(s) activate, ignoring Parameter 16-776 (Up To Speed Delay).
  - a. The KP Relay is Active (LED on).
  - b. The KM Relay LED is Active (LED on).
  - c. The Neutral Relay is Active (Command and Feedback LEDs on).
  - d. The Start Motor output is Inactive (LED off).
  - e. The DOWN Valve(s) are Active (Command and Feedback LEDs on).

- f. The UP Valve(s) are Inactive (Command and feedback LEDs off).
- g. The car moves.
- 5. Once the slowdown point has been reached, the DH valve is Inactive (Command and Feedback LEDs off).
- 6. Once the car levels to door zone, the DL valve is Inactive (Command and Feedback LEDs off).
- 7. The Neutral Relay drops after Parameter 16-779 (Neutral Relay Drop Delay) elapses. The Command and Feedback LEDs off.
- 8. The Safe Relays drops after Parameter 16-778 (Safe Relay Drop Delay) elapses.
  - a. The KP Relay LED turns off.
  - b. The KM Relay LED turns off.

### 1.7.3 CAR MOTION PRE-RUN SEQUENCE - TRACTION

The pre-run process is a sequential set of stages (sub-states) followed before moving the car. Each of these stages will do some different combination of checks and commands.

1. **Check Doors:** Check if car doors and hall doors are in a state that's safe for movement. If door checks pass, the controller will proceed to the next stage.
2. **Safe Relay:** The safe relay (KP and KM) as well as the B2 output is activated. The effect of activating the safe relay is activation of the motor contactor, so the controller will wait for the mappable "Motor Contactor" input to be seen active. After seeing the motor contactor active, zero speed and direction is commanded to the drive, and the controller will proceed to the next stage.
3. **Wait Drive:** Wait for drive active feedback. If the drive is F6, wait for the drive to signal STO/SBC. If the drive is F5, wait for the "drive-on" signal. If the drive active feedback is seen, proceed to the next stage.
4. **Wait Brake Contactor:** After activating the drive, the drive activates the main brake contactor, so the controller waits until the mappable "Main Brake Contactor" input is seen active. Additionally, since the B2 output was activated during the "Safe Relay" stage, any contactor connected to this output should also be active now. If parameter 1-113 "Enable Auxiliary Serial Brake" is set to ON, the controller will wait until the mappable "Aux Brake Contactor" input is seen active.
5. **Brake Pick Command:** Flags to "pick after delay", and "hold after pick" are set for the main brake. These flags communicate to the DC brake board. The brake should be commanded to pick after a period defined by parameter 8-110 "Main Serial Brake Pick Delay". After picking, the brake should be commanded to hold for a period defined by parameter 8-112 "Main Serial Brake Pick To Hold Time". If the aux brake is enabled, and not being held, it will be commanded to pick immediately, then hold after a period defined by parameter 8-115 "Aux Serial Brake Pick To Hold Time".
6. **Brake Pick Delay:** Since the flag to "pick after delay" was set in the last stage, it is this stage the controller will wait for the brake command to become "pick", then proceed to the next stage.
7. **Run Speed Delay:** Wait for period defined by parameter 8-121 "Run Speed Delay" to give time for the brake to physically pick before commanding movement, then proceed to the next stage.
8. **Recheck Run:** Final checks before exiting pre-run and entering run state. Car and hall doors are checked again to ensure that they are in a safe state for movement.

## 1.7.4 CAR MOTION POST-RUN SEQUENCE - TRACTION

---

The post-run process is a sequential set of stages (sub-states) that is step through before dropping all motion signals. Each of these stages will do some different combination of checks and commands.

These stages are:

1. **Drop Brake Command:** Message is sent to the brake board that the brake should be commanded to drop after period defined by parameters 8-111 "Main Serial Brake Drop Delay" and 16-943 "Aux Serial Brake Drop Delay" for the main/aux brakes respectively.
2. **Drop Brake Delay:** At this stage the controller will wait for the main brake command to become "drop", then proceed to the next stage. Aux brake command is not checked because it can stay picked between runs.
3. **Drop Safe Delay:** Wait for the period defined by parameter 16-778 "Safe Relay Drop Delay". This gives time for the brake to physically drop before proceeding to the next stage.
4. **Drop Safe Relay:** The safe relay will be dropped. This will cause the main brake and motor contactors to drop which will be checked at mappable inputs "Motor Contactor" and "Main Brake Contactor". Additionally, the drive is checked for deactivation. If these checks pass, the post-run process will transition to complete.

# Section 2 Modes of Operation

## 2.1 NORMAL OPERATION MODE

The car takes car calls and runs passengers to and from floors normally. On the **Home** screen, **Mode of Operation** reads **Normal**.

## 2.2 OUT OF SERVICE

Out of Service Mode takes the car out of service. The car moves to the bottom floor and holds door(s) open. On the **Home** screen, **Mode of Operation** reads **Out of Service**.

There are multiple ways to activate this mode.

### 2.2.1 ACTIVATE OUT OF SERVICE BY INPUT

1. Set parameter 1-54 (Disable Out of Service) to off.
2. Set the Out of Service input to active.
3. On the **Home** screen, **Mode of Operation** changes to **Out of Service**.
4. If parameter 1-106 OOS Recall Floor is off, the car recalls in place if it is in DZ.
5. If parameter 8-71 OOS Recall Opening is 0, the car opens the front door and holds open.
6. Once door(s) are fully open, the car faults with a 178 OOS Input Fault.
7. To remove the car from Out of Service, set the Out of Service input inactive.
  - On the **Home** screen, Mode of Operation changes to **Normal**.
  - The fault clears.

### 2.2.2 ACTIVATE OUT OF SERVICE BY REPEATED FAULTS

1. Set parameter 1-54 Disable Out of Service to off.
2. Set parameter 8-26 Repeated Fault Limit is to 6.
3. Activate the same fault 7 times.
4. On the **Home** screen, Mode of Operation changes to Out of Service.
  - If parameter 1-106 OOS Recall Floor is off, the car recalls in place if in DZ.
  - If parameter 8-71 OOS Recall Opening is 0, the car opens the front door and holds open.
5. Once the door(s) are fully open, the car faults with a 499 OOS Repeat Fault.
6. To remove the car from Out of Service, press the MR fault reset button.
  - On the **Home** screen, Mode of Operation changes to **Normal**.
  - The fault clears.

### 2.2.3 ACTIVATE OUT OF SERVICE BY RUNTIME LIMIT

1. Set parameter 1-54 Disable Out of Service to off.
2. Set parameter 8-40 Run Time Limit to 50 seconds.
3. Place a car call at the furthest landing.
4. On the **Home** screen, Mode of Operation changes to Out of Service.
5. If parameter 1-106 OOS Recall Floor is off, the car recalls in place if it is in DZ.
6. If parameter 8-71 OOS Recall Opening is 0, the car opens the front door and holds open.
7. Once the door(s) are fully open, the car faults with 160 Max Runtime fault.
8. To remove the car from Out of Service, press the MR fault reset button.
  - On the **Home** screen, Mode of Operation changes to **Normal**.
  - The fault clears.

## 2.2.4 ACTIVATE OUT OF SERVICE BY STARTS PER MINUTE LIMIT

---

1. Set parameter 1-54 Disable Out of Service to off.
2. Set parameter 8-43 Starts Per Minute Limit to 1. Place 2 CCs close to each other.
3. On the **Home** screen, Mode of Operation changes to Out of Service.
4. If parameter 1-106 OOS Recall Floor is off, the car recalls in place if it is in DZ.
5. If parameter 8-71 OOS Recall Opening is 0, the car opens the front door and holds open.
6. Once the door(s) are fully open, the car faults with fault Max Starts Per Minute fault.
7. To remove the car from Out of Service, press the MR fault reset button.
  - On the **Home** screen, Mode of Operation changes to **Normal**.
  - The fault clears.

## 2.2.5 ACTIVATE OUT OF SERVICE BY HOURLY FAULT LIMIT

---

1. Set parameter 1-54 Disable Out of Service to off.
2. Set parameter 8-54 General Fault Hourly Limit to 5. Activate 5 different faults.
3. On the **Home** screen, Mode of Operation changes to Out of Service.
4. If parameter 1-106 OOS Recall Floor is off, the car recalls in place if it is in DZ.
5. If parameter 8-71 OOS Recall Opening is 0, the car opens the front door and holds open.
6. Once the door(s) are fully open, the car faults with 502 OOS Hourly fault.
7. To remove the car from Out of Service, press the MR fault reset button.
  - On the **Home** screen, Mode of Operation changes to **Normal**.
  - The fault clears.

## 2.2.6 ACTIVATE OUT OF SERVICE BY DOOR FAULT LIMIT

---

1. Set parameter 1-54 Disable Out of Service to off.
2. Set parameter 8-55 Door Fault Hourly Limit to 5. Activate 5 different door faults.
3. On the **Home** screen, Mode of Operation changes to Out of Service.
4. If parameter 1-106 OOS Recall Floor is off, the car recalls in place if it is in DZ.
5. If parameter 8-71 OOS Recall Opening is 0, the car opens the front door and holds open.
6. Once the door(s) are fully open, the car faults with 501 OOS Hourly Door fault.
7. To remove the car from Out of Service, press the MR fault reset button.
  - The fault clears
  - On the **Home** screen, Mode of Operation changes to **Normal**.

## 2.3 CONSTRUCTION MODE

Construction Mode allows the manual running of the elevator using onboard buttons or an external run box without any devices connected other than power, pump and valves. See section 3.3.1 Entering Construction Mode. When used, the external pendant station will connect to Hoistway Access terminals through the MR Board (ABDN, ABUN, ATDN, ATUP). Reference the job specific prints for a detailed wiring scheme.

To enter Construction Mode, Set the MR inspection to INSP (Toggle if already on INSP) and set DIP2 to ON (up) then DIP3 to ON. Mode of Operation reads Construction.



If the Car top is not connected or Cartop inspection switch needs to be bypassed, DIP7 must be turned ON.



Any time the mode is exited, the DIP switch must be toggled from OFF to ON.

To bypass virtual hoistway devices, the virtual limits must be bypassed (Adjust > Inspection > Bypass Landing System Feedback ON).

- Selector Feedback
- Normal limits
- NTS
- TSRD

## 2.4 MACHINE ROOM INSPECTION MODE

The Machine Room Inspection Mode is initiated by placing the inspection switch on the MR board in the inspection position. Machine room inspection mode permits operation of the car from the machine room inspection switches. Mode of Operation reads MR Inspection.

- All safety devices are active and must be made.
- Gate switch, Door Position Monitor (DPM, if programed), Hall locks and Car gates/locks are active and must be closed.
- The Elevator moves at the inspection or leveling valve speed, which is limited to 150 fpm.

### Inspection Operation hierarchy:

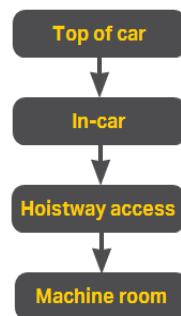

Figure 25: Inspection Operation Hierarchy

## 2.5 TOP OF CAR INSPECTION MODE

---

Perform Top of Car Inspection as per A17.1 2.26.1.4.

### 2.5.1 HOW TO ACTIVATE

---

Initiate Top of Car Inspection Mode by placing the inspection switch (DC Input 03 on CT) on the car top in the INSP position (Active LOW). Top of Car Inspection Mode permits operation of the car from the Enable and UP/DOWN switches on the inspection station. Mode of Operation reads CT Inspection.

- Gate Switch, Door Position Monitor (DPM, if programmed), Hall Locks and Car gates/locks are active and must be closed.
- The elevator moves at the inspection or leveling valve speed. Limited to 150 fpm.

To move the car on manual operation before a hoistway learn is complete, the virtual limits must be bypassed (Adjust > Inspection > Bypass Landing System Feedback ON).

### 2.5.2 DOOR BEHAVIOR ON CT INSPECTION

---

Automatic power door opening and closing is disabled. The opening and closing of the doors is permitted using door open/close inputs. Doors can only open when the elevator is in the DZ.

When the MR board door Bypass switch is ON (set to CAR BYPASS), the car can move with the car doors not fully closed, but the hall doors should remain fully closed. If the MR board hall bypass switch is ON (set to HALL BYPASS), the car can move with the hall locks open, but the car doors must be closed. If both are on, then the car can move with both open.

To fully open the door, door open input must be held high until the doors are in fully open state.

To fully close the door, door close input must be held high until the doors are in a fully closed state.

## 2.6 HOISTWAY ACCESS MODE

---

Hoistway access mode is initiated by placing the key operated access switch located in the car operating panel (DC Input 03 on COP) to the enable position (Active LOW). This allows the movement of the car with the hoistway door near the switch in an unlocked or not closed position, and the car door associated with this hoistway door unlocked or not closed position.

- Allow running the car using access key switches at the top or bottom access openings.
- Bypasses the gate switch to allow car movement with the car door open.
- Bypasses the top or bottom access opening hall door lock, depending on which terminal access switch is being keyed.
- The bottom hoistway access switch enables the car to move in the up direction up to 96 in. from the floor level to the bottom of the platform guard.



Bottom access lock must be wired to Lock Bottom Access (LBA) input and Top access lock must be wired to Lock Top Access (LTA) input.



The movement of the car initiated and maintained by the access switch at a landing other than the lowest landing is limited in the down direction to a travel not greater than the height of the car crosshead above the car platform and limited in the up direction to the distance the platform guard extends below the car platform.

## 2.7 FIRE PHASE 1 MAIN RECALL

---

Fire phase I recall is initiated when the designated smoke sensor is activated, or the lobby fire key is turned to the ON position. The main recall floor is usually the lobby floor but could be another landing depending on AHJ requirements. When Fire Service Phase I is enabled:

- The fire key and lamp connections (both 24VDC) are to be terminated in the Machine Room.
- The lobby fire lamp and the fire buzzer are turned on.
- All hall calls and car calls are dropped and the car travels to the main recall floor and parks with the door open. Once the doors are fully open, the fire buzzer turns off.
- The in-car stop switch is disabled when the door closes to begin Phase 1 recall (depending on code requirement).
- If the car is at a landing with the doors open, the doors close, Photoeye (PHE) is disabled, and the car recalls nonstop to the main recall floor.
- If the car is traveling away from the recall floor, the car stops at the next achievable landing, and then immediately changes directions to the recall floor without cycling the doors.

Transitioning the fire service key switch to the bypass/reset position restores the elevator to normal operation if the fire initiating devices are deactivated and the car is at the designated landing with doors open.



Other applicable Code requirements may apply.

## 2.8 FIRE PHASE 1 ALTERNATE RECALL

---

Fire service phase I alternate return is initiated when the lobby smoke sensor is activated. When fire service phase I alternate return is enabled:

- The lobby fire lamp and the fire buzzer are turned on.
- All hall calls and car calls are dropped and the car travels to the alternate recall floor and parks with the door open. Once the doors are fully open, the fire buzzer turns off.
- The in-car stop switch is disabled when the door closes to begin Phase 1 recall (depending on code requirement).
- If the car is at a landing with the doors open, the doors close and the car recalls nonstop to the alternate recall floor.
- If the car is traveling away from the recall floor, the car stops at the next achievable landing, and then immediately changes directions to the recall floor without cycling the doors.
- Transitioning the fire service key switch to the bypass/reset position restores the elevator to normal operation.

## 2.9 FIRE PHASE 2 MODE

---

Fire phase II can be initiated when the car completes Fire Service Phase I recall with the door fully open. The Fire Phase II key switch located in the car operating panel must be placed in the ON position.

This mode performs operations in accordance with ASME A17.1 as follows:

- The doors close only with constant pressure on the door close button, after they have been fully opened.
- The doors open only with constant pressure on the door open button, after they have been fully closed.
- Hall calls, Hall lanterns and gongs are disabled. Safety edge and electric eye are disabled.
- Registered car calls can be canceled with momentary pressure on the call cancel button located in the car operating panel.
- To remove the car from fire service phase II the car must be at the fire return landing with the doors in the fully open position and the phase II switch turned to the off position.



Other applicable Code requirements may apply.

---

## 2.10 AUXILIARY POWER LOWERING

---

In Auxiliary Power Mode, the system uses an auxiliary power supply to lower the car in the event of power loss, as per A17.1 3.26.10. To activate this mode:

1. Set On Battery Power input active. **Mode of Operation** changes to **Battery Rescue**.
2. **Alarm 97 Battery Rescue Active** is activated.
3. The car recalls to the bottom landing.
4. Once the car reaches the bottom landing, the door(s) cycle.
5. The car remains faulted with fault **505 Battery Rescue**.
6. To exit battery rescue operation, set **On Battery Power** to **Inactive**.
  - **Mode of Operation** changes to **Normal**.
  - **505 Battery Rescue** fault clears.
  - **97 Battery Rescue Active** alarm clears.

## 2.11 LOW OIL MODE

**Low Oil** input is monitored by a normally closed dry contact actuated by an external device located in the power unit. This is fed back to the system via a 24VDC **Low Oil** input on the MR board.



If **Low Oil** contact is normally open, **Input** can be inverted in the **Adjust > Input** menu.

When the **Low Oil** input is activated, the car aborts its current run (this stops the run in transit at its current point) and returns to the bottom landing, where it opens its doors and initiates the closing sequence within 15 seconds of the doors fully opening. The car then goes out of service. The in-car door open button remains operative, but no other functions cause the door to re-open, including hall calls at the landing or Manual Door Open buttons for Freight doors located in the hallway.

**Low Oil** requires a manual reset, which means the fault latches through a power cycle of the controller and can only be cleared via a fault reset button press.

## 2.12 MOTOR OVERHEAT MODE

**Motor Overheat** input is monitored through a normally open dry contact actuated by a thermal switch located inside or connected to the pump motor. This is fed back to the system via a 24VDC Motor Overheat input on the MR board.

When the **Motor Overheat** input is activated, the car aborts its current run and returns to the bottom landing, where it opens its doors and initiates the closing sequence within 15 seconds of the doors becoming fully open. The car then goes out of service. The in-car door open button remains operative, but no other functions cause the door to re-open, including hall calls at the landing or Manual Door Open buttons for Freight doors located in the hallway.

Once the motor cools and the **Motor Overheat** input goes inactive, the fault clears automatically, and the car returns to normal operation.

## 2.13 LOW PRESSURE

### 2.13.1 OVERVIEW

**Low Pressure** input is monitored by a normally closed dry contact actuated by an external pressure sensing device, as per A17.1. During Low Pressure Operation, running cars stop in flight and do not actuate the down valves until the issue is cleared. The car then tries to run up to the nearest door zone (DZ). Once the car arrives in the DZ, the doors do not automatically open, but the Door Open buttons work while the car remains in the DZ. If the car is running up, it continues the run to the nearest DZ and prevents the doors from automatically opening. The door open buttons remain active while the car is stopped in the DZ.

Once the car completes either of these operations, the car goes out of service until the fault is cleared.



Low Pressure is ignored during recycling operation (Jack Sync) and is not monitored again until the car returns to the DZ after the sync is complete. Once it reaches 3fpm, there is sufficient pressure to assert movement, and the switch should be inactive again.

## 2.13.2 HOW TO ACTIVATE

---

1. Place the controller in automatic **Normal** operation mode. On the **Home** screen, **Operation Mode** displays **Normal**.
2. Map the **Low Pressure** input to the controller (if not already mapped).
3. Set the input active. On the **Home** screen, **Operation Mode** displays **Low Pressure**.
  - a. If the car is not moving and in DZ:
    - Active fault displays **162 Low Pressure** and the fault LEDs blink.
    - DOB works.
  - b. If the car is moving up:
    - The car continues up to the nearest DZ.
    - Once the DZ, the UI active fault displays **162 Low Pressure** and the fault LEDs blink.
    - DOB works if in DZ.
  - c. If the car is moving down:
    - i. The car stops, then attempts to run up to the nearest DZ.
    - ii. Once at DZ, the active fault displays **162 Low Pressure** and the fault LEDs blink.
    - iii. DOB works if in DZ.
4. To remove the car from **Low Pressure** mode, set the input inactive.
  - **Operation Mode** displays **Normal**.
  - Active fault clears.
  - Fault LEDs turn off.

## 2.14 JACK SYNC

---

### 2.14.1 OVERVIEW

---

**Jack Sync**, or recycling operation, is used when multiple pistons are used for hydraulics to equalize pressure. The function allows the car to be lowered below the bottom landing to restore the alignment, as per A17.1 3.26.7.

The car must be:

- At rest at the bottom landing
- Car and Hall doors closed
- No active car calls
- The car remains out of service until the operation is complete and the car is back at the bottom landing in normal operation.
- The car descends at leveling speed, not exceeding 20 ft/min.
- NTSD and Releveling can be bypassed during Jack Sync.



Jack Sync can be canceled if the car has not been recalled to the bottom landing. Once the car arrives at the bottom landing, Jack Sync exits after the procedure is complete.

---

## 2.14.2 HOW TO ACTIVATE

### 2.14.2.1 ACTIVATE BY INPUT

1. Place the controller in automatic **Normal** operation mode. On the **Home** screen, **Operation Mode** displays **Normal**.
2. Map the **Jack Sync** input to the controller (if the input is not already mapped).
3. Set the input active.
  - On the **Home** screen, **Operation Mode** displays **Jack Sync**.
  - Active alarm displays **63 Jack Sync Active** and the alarm LEDs blink.
  - The car continues to take car calls.
4. Once the car is idle for three seconds, it recalls to the bottom landing.
5. Once at the bottom landing, the car runs down (and bypasses NTS) at leveling speed for parameter 8-65 (Jack Sync Duration) duration in seconds.
6. Once the duration timer elapses, the car runs up at leveling speed to the bottom landing DZ.
7. Once the car reaches DZ, the car exits **Jack Sync** and on the **Home** screen **Operation Mode** changes to **Normal**.
8. The active alarm clears, and the alarm LEDs turn off.

### 2.14.2.2 ACTIVATE BY DAY/TIME

1. Place the controller in automatic **Normal** operation mode. On the **Home** screen, **Operation Mode** displays **Normal**.
2. Set parameter 16-771 (Jack Sync Time and Day) to today's day and a few minutes ahead of the current time.
3. When the parameter time and day matches with the current RTC time and day:
  - **Operation Mode** displays **Jack Sync**.
  - The UI active alarm displays 63 Jack Sync Active and the alarm LEDs blink.
  - The car continues to take car calls.
4. Once the car has been idle for three seconds, the car recalls to the bottom landing.
5. Once the car reaches the bottom landing, the car runs down (and bypasses NTS) at leveling speed for the parameter 8-65 (Jack Sync Duration) duration in seconds.
6. Once the duration timer elapses, the car runs up at leveling speed to the bottom landing DZ.
7. Once the car reaches DZ, the car exits Jack Sync and on the **Home** screen **Operation Mode** changes to **Normal**.
8. The active alarm clears, and the alarm LEDs turn off.

## 2.15 INDEPENDENT SERVICE MODE

**Independent Service** is a mode of operation used by elevator operators that removes the elevator from normal group service (i.e., the elevator operates independently of other elevators in the system), as per A17.1 2.27.5 Firefighters' Emergency Operation: Automatic Elevators with Designated-Attendant Operation.

## 2.15.1 OVERVIEW

When on **Independent Service**, the car runs from floor to floor in response to registered car calls only. The car does not respond to hall calls, nor does it “park” when idle, but remains with at least one set of doors open until DCB is activated.

Place a car in **Independent Service** mode. The switch for this is usually in the car operating panel (COP) in the elevator cab. (There can be other locations for that switch, inside or outside of the elevator cab, based upon specific requirements of the elevator site.)

When a car is placed on **Independent Service**, a one-time cancellation of all registered car calls is executed. After that one-time cancellation, new car calls can be registered. (The one-time cancellation is traditional behavior; a configuration option can be created to change this behavior.)

## 2.15.2 HOW TO ACTIVATE

1. Place the controller in automatic **Normal** operation mode. On the **Home** screen, the **Operation Mode** displays **Normal**.
2. Map the **Independent Service** input to the controller if the input is not already mapped.
3. Set the input active. **Operation Mode** displays Independent. If the car is moving:
  - a. The car clears its car calls when the mode of operation changes from Normal to Independent (if the parameter 1-32 Independent Cancel CCs on Entry is ON).
  - b. The car makes a no-demand stop and opens the door associated with the landing.
  - c. The door stays open and closes when holding DCB with constant pressure.
  - d. If DCB is released, the door reopens.
  - e. If parameter 1-58 Independent Service Door Close on CCB is ON, press and hold with constant pressure a CCB. The doors close and the destination latches. Otherwise DCB with constant pressure and a CCB press is required to latch a destination.
  - f. Multiple car calls can be placed, but If parameter 1-65 Independent Service Cancel CCs is ON, all car calls are cleared after a car call is answered. Otherwise, they remain latched.
4. If the car is idle:
  - a. The car opens the door associated with the landing.
  - b. The door stays open until closed by DCB with constant pressure.
  - c. If DCB is released, the door reopens.
  - d. If parameter 1-58 Independent Service Door Close on CCB is ON, press and hold with constant pressure a CCB. The doors close and the destination latches. Otherwise DCB with constant pressure and a CCB press is required to latch a destination.
  - e. Multiple car calls can be placed but if the parameter 1-65 Independent Service Cancel CCs is ON, all car calls are cleared after a car call is answered. Otherwise, they remain latched.
5. To remove the car from Independent Service, set the input inactive. **Operation Mode** displays **Normal**.

## Section 3 Installation



These installation procedures are for a typical installation. Your elevator setup and options may differ, so alter these procedures where necessary.

### 3.1 SITE PREPARATION

When selecting the best physical location for the control equipment consider the following:

- Ensure the control system is placed logically, considering all elevator system components and non-elevator equipment sharing the space.
- Use four 3/8" diameter Grade 5 Zinc Finish Hex Cap Screws, four 3/8" Zinc Finish Lock Washers, and four 5/16" x 0.875"OD Zinc or Galvanized Finish Steel Flat Washers in the designated enclosure mounting holes to secure controller.
- Provide adequate working space for control system installation, wiring, and maintenance. Nexus™ standard equipment enclosures require front access only. This eliminates many constraints that would otherwise limit how equipment can be located.
- Do not install equipment where it may create a hazard.



Install equipment according to all applicable electrical, fire, and building codes. Improper installation and/or equipment location may create a **HAZARDOUS CONDITION**.

- Do not install control system components in areas or on surfaces where there is exposure to vibration that may be produced by other equipment. Modern control systems contain socket-mounted parts whose function may be compromised by vibration.
- Provide adequate lighting for safety and efficiency.
- If cellphone reception at the installation location is poor or intermittent, then a wired phone installed in the machine room is recommended.

## 3.1.1 ENVIRONMENTAL CONSIDERATIONS

Install the elevator control system according to the following requirements to ensure proper operation and longevity:

1. Temperature inside the control system enclosure should be maintained between 32- and 104-degrees Fahrenheit (0 to 40 degrees Celsius). Temperatures outside this range may affect normal operation and/or reduce system life. If required, make provisions for machine room air conditioning. Vantage can quote and provide an enclosure-mounted air conditioning unit.
2. Machine room air should remain free of corrosive gases and sufficiently dry to prevent condensation from moisture. NEMA 4 or NEMA 12 enclosures, with integral air conditioning units, are recommended for applications that do not meet these requirements. Vantage can quote and provide the full range of specialized NEMA rated enclosures for proper and safe operation in non-standard environments.
3. Locate control system enclosures and components away from any window or opening to minimize the risk of equipment damage due to severe weather conditions.
4. Protect control system equipment from exposure to extreme levels of electromagnetic (EM) and radio frequency (RF) radiation. Vantage systems are certified to meet current EMI/RFI standards. However, note that EMI and RFI can interfere with electronic systems.



Hand-held communications devices used close to the system CPUs have been known to generate disruptive RF interference.

## 3.1.2 RECOMMENDED TOOLS, TEST EQUIPMENT & MANUALS

The following tools are recommended for installation:

- Digital multi-meter
- Assorted tools used for electronics work such as pliers, cutters, screwdrivers, etc.
- Amprobe or similar probe equipped amp meter
- Telephone
- Test weights
- Torque wrench capable of 40–50 Nm (33.19–36.87 lb-ft)
- Control system “as built” job wiring prints
- This installation and adjustment manual
- Solid State Starter Motor Control Manual, if applicable
- Oscilloscope may be desirable for advanced troubleshooting (rarely required)

## 3.2 INSTALL THE CONTROL SYSTEM

Mount the controller enclosure in the machine room.

### 3.2.1 INSTALL THE CONTROLLER CABINET



Use appropriate lockout/tagout (LOTO) procedures while running any mechanical functions in Construction Mode. Follow company approved lockout/tagout procedures, ensuring that hazardous energy is completely controlled and preventing accidental startup or release of stored energy while work is in progress. Always consult company documented lockout/tagout procedures for the exact steps.

### 3.2.2 WIRE THE CONTROL SYSTEM



Proper grounding is vitally important to the safe and successful operation of this system, and proper grounding must be installed to comply with all applicable codes. A separate ground wire must be installed from the building earth ground to the earth ground terminal in each controller. Proper conductor size must be used for grounding. To minimize resistance to ground, the shortest possible length must be used for the ground conductor. All installation and wiring must meet national electrical code and all local codes. The 3-phase AC power supply to the equipment must originate from a properly fused disconnect or circuit breaker that is properly designed and sized for the specific controller requirements and the Short Circuit Current Rating listed on the controller.

#### 3.2.2.1 TEST GROUND CONTINUITY

Test all non-ground terminals for continuity to ground. If continuity is found, resolve the problem before proceeding.

#### 3.2.2.2 WIRE MAINLINE TO CONTROLLER

Wire the main line from the disconnect switch to the motor starter or terminal block provided in the controller enclosure as indicated on job prints page 4.

#### 3.2.2.3 VERIFY SUPPLY VOLTAGES

1. Turn on the disconnect switch to verify that voltages at controller terminals are correct based on the electrical schematic.
2. Turn off the disconnect switch then turn ON L1-L2 2-pole breaker.
3. Turn ON the disconnect switch and confirm that the input to PS breaker is 120VAC.
4. Turn ON PS breaker and verify input to MR24 and CT24 breakers are 24 volts DC (Adjust the power supply output as needed to get withing 10% of 24VDC). Turn ON MR24 breaker. Verify that buss voltages (Blue Buss block) are 24 volts DC; and 120VAC (Red Buss block).
5. Confirm that the MR board display is ON, and the processor Heartbeat (HB) green LEDs are blinking.

#### 3.2.2.4 WIRE MOTOR LEADS TO PUMP UNIT

Verify motor data tag information to the information found on page 3 of prints. Wire according to motor data tag for appropriate application. Contact Vantage Technical Support before proceeding if there is any discrepancy between the motor data tag and prints.

#### 3.2.2.5 WIRE VALVE COILS TO CONTROLLER

Verify valve coil voltages. Wire valve coils according to page 4 of job prints.

#### 3.2.2.6 WIRE TEMPORARY PENDANT STATION

Wire Pendant station according to page 5 of job prints.



To enable Construction Mode, set MR inspection switch to INSP and turn ON DIP switch 2 and then DIP switch 3. The **Home** screen will display Construction Mode. If cartop is not connected or CT inspection is active, DIP 7 must be ON.

## 3.3 STARTUP PROCEDURE

### 3.3.1 ENTERING CONSTRUCTION MODE

The Nexus™ Controller comes prepared to run on Construction Mode, which will allow the elevator to run while the safety devices are being installed after completing the following steps.



If controller has not learned the hoistway or landing system is not installed, landing system feedback must be bypassed in the inspection menu (**Adjust > Inspection > Bypass Landing System Feedback > ON**).



If Construction mode exits, it must be reentered by setting the inspection switch to INSP (Toggled) and toggling DIP2 and then DIP3 from OFF to ON.



DIP7 Must be turned ON if bypassing Cartop Inspection switch.

To Run in Construction Mode:

1. The following signals are bypassed when in Construction mode
  - Hall Locks
  - LBA: Lock Bottom Access – AC input 01
  - LTA: Lock Top Access – AC input 02
  - LCKF: Lock Front – AC input 03
  - LCKR: Locks Rear – AC input 04
  - PIT: Pit switch – AC input 09
  - BUF: Buffer Switch – AC input 10
  - BFL: Bottom Final Limit – AC input 11
  - TFL: Top Final Limit – AC input 12
  - ALL In-Car and Cartop devices.
  - Any other applicable AC input. AC inputs 13-16 may be used in future releases, refer to the Machine Room I/O Continued page of prints.
2. The machine room inspection switch must be set to INS.
3. Set DIP2 to ON(UP) and then DIP3 to ON(UP) position to enter Construction Mode. Mode of Operation will display Construction. DIP 7 Set ON if Cartop is not connected.
4. The following connections are needed when using a temporary pendant station. Verify the **ACCESS** inputs are set in the inspection menu (**Adjust > Inspection > Construction Mode Run Controls > Access**).
  - a. Access Bottom UP (AC Input 05): Stop switch input (if low, stops all movement. Must be ON to run).
  - b. Access Bottom Down (AC Input 06): Enables input monitoring (Must be ON before a direction is enabled).
  - c. Access Top Up (AC Input 07): Moves the car down
  - d. Access Top Down (AC Input 08): Moves the car up



The enable switch must be held while the direction input is applied, and released when the direction input is released.

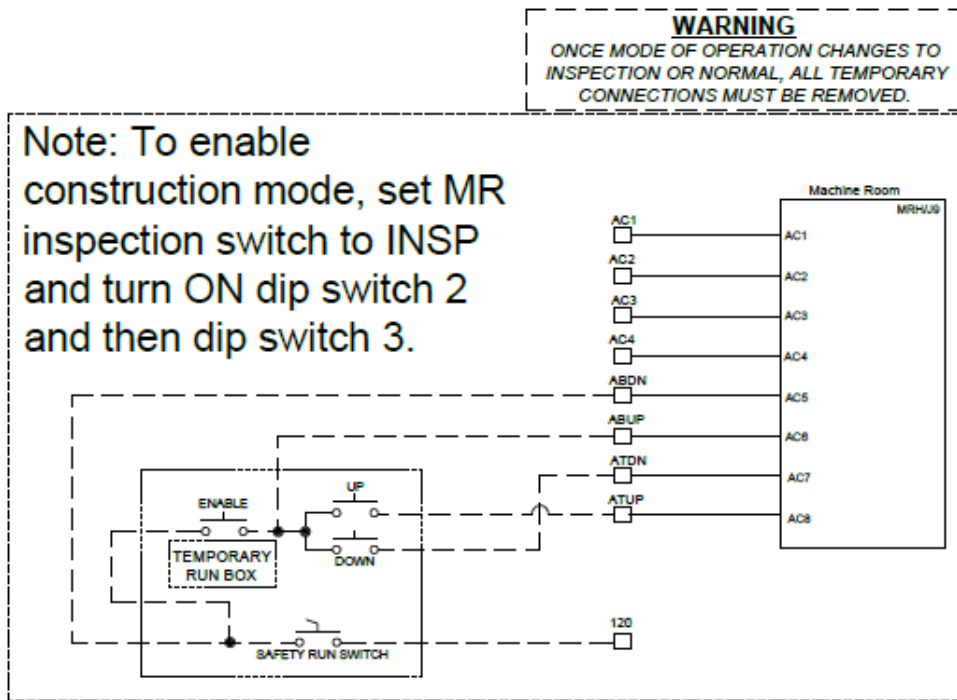

Figure 26: Construction Mode Run Box Connections

### 3.3.2 VERIFY PUMP MOTOR ROTATION - HYDRAULIC

Read the manufacturer’s solid-state starter unit (SSSU) application instructions and use them for reference in this section. The ready light illuminates when power is applied to the input side of the SSSU. If there is phase loss, the phase reverse indicator comes on. Verify that the line-to-line voltage is the proper value. If incorrect, swapping any two power input lines to the starter should correct the problem, and the LED ready indicator should come on. Refer to SSSU manufacturer’s manual for advanced troubleshooting.

### 3.3.3 ATTEMPT TO MOVE THE CAR - HYDRAULIC

Verify proper operation of elevator components while confirming the car moves up and down.

#### 3.3.3.1 CONFIRM SHUTOFF VALVES AND CLEARANCES

Confirm hydraulic shutoff valves are open and ensure there’s sufficient clearance to avoid contact with any hoistway obstructions.

#### 3.3.3.2 CONFIRM VALVE SOLENOID OPERATION

Run the car on MR Inspection to verify valve activation. If running low speed, UL for UP and DL for Down should activate. The command can be verified on the **Home** screen Command section and by the command LEDs on the valve board. If all is active but the car doesn’t move, confirm the valve circuit output by measuring voltage at the appropriate valve terminal (UL/DL/UL/UH) to N, and verifying 120VAC is present when the circuit is active.

### 3.3.3.3 VALVES ADJUSTMENT

---

Perform per valve manufacturer's adjustment instructions.

### 3.3.3.4 DETERMINE DESIRED INSPECTION SPEED

---

Run the inspection on Low Speed or High Speed.

#### 3.3.3.4.1 RUNNING ON INSPECTION LOW SPEED

---

Run the car Up/Down while on inspection and verify only Low speed valves (UL/DL) are actuating. If speed feedback is active, verify the Inspection speed in the Inspection menu matches the desired speed.

#### 3.3.3.4.2 RUNNING ON INSPECTION HIGH SPEED

---

To engage the highspeed valve on inspection, set the Inspection speed (Found in Adjust → Inspection) equal to the contract speed.



Inspection speed cannot be set higher than 150 fpm. If the elevator is detected moving >150 fpm, it activates an Inspection Overspeed fault.

---

If Leveling valve is required to be engaged with Highspeed valve, the option can be set for the UP and the DOWN independently in the Adjust → Control Menu.

### 3.3.4 ADJUST THE BRAKE VOLTAGE - TRACTION

---

The controller utilizes an electronic brake board that is triggered from the Safety Processor on the Main I/O board. To adjust the brake voltage, navigate to the "Adjustable Variables" menu, and "Car Brake" sub menu on the LCD Interface. Set the "Brake Pick Volt", "Brake Hold Volt" and "Brk AC L-L Volt" to the proper values. Verify these voltages at the brake board AC1/AC2/AC3 and BK+/BK- terminals once it is possible to pick the brake.

### 3.3.5 VERIFY DRIVE PARAMETERS

Check the KEB F6 drive settings are set according to the job schematics and the defaults shown in **Table 2**.

*Table 2: KEB F6 drive settings*

Drive Parameter	Value	Drive Parameter	Value
<b>US - Basic Setup Parameters</b>		<b>LC - Control Settings Parameters</b>	
US03: Motor Type	JOB SPECIFIC	LC01: Control Mode	2: Closed Loop FOC + Basic Pre-Torque
US04: Control Type	5: Serial Speed DIN66019 serv. 50	<b>LT - Timer Parameters</b>	
US06: Contract Speed	JOB SPECIFIC	LT01: Brake Release Delay	0.00s
<b>LI - Input Parameters</b>		LT02: Control Hold Off	.40s
LI04: Input 1 Function	21: Emergency Slowdown	LT03: Speed Start Delay	3.00s
<b>LM - Motor Data Parameters</b>		LT10: Brake Drop Delay	0.00s
LM01: Motor Power	JOB SPECIFIC	LT12: Current Hold Time	0.00s
LM02: Motor Speed	JOB SPECIFIC	LT13: Current Ramp Down Time	0.75s
LM03: Motor Current	JOB SPECIFIC	<b>LO - Output Parameters</b>	
LM04: Motor Frequency	JOB SPECIFIC	LO20: Output Brake X1C	3: Drive on
LM05: Motor Voltage	JOB SPECIFIC	LO25: Output Function SW	13: Condition 1
LM07: Motor Torque	JOB SPECIFIC	LO30: Data Value 1	6: dg06
<b>LE - Encoder Parameters</b>		LO31: Condition 1	6: dg06
LE01: Encoder 1 Interface	JOB SPECIFIC	LO32: Comparison Level 1	0.0
LE02: Encoder 1 Pulse Number	JOB SPECIFIC	<b>LX - Special Functions Parameters</b>	
<b>LN - Machine Data Parameters</b>		LX02: Switching Frequency	2: 8KHz : Base 2 KHz : Base 2 KHz
LN01: Traction Sheave Diameter	JOB SPECIFIC	LX27: IP Address	192.168.0.2
LN02: Gear Reduction Ratio	JOB SPECIFIC	LX28: IP Subnet Mask	255.255.255.0
LN03: Roping Ratio	JOB SPECIFIC	LX29: IP Gateway Address	192.168.0.2

## 3.3.6 MOTOR LEARN PROCEDURE - TRACTION

Before starting the motor learn procedure, verify the wire connections between the drive, motor contactor and the motor.

To perform a motor tune, please follow these steps:

1. Go to **Adjust/Learn**.

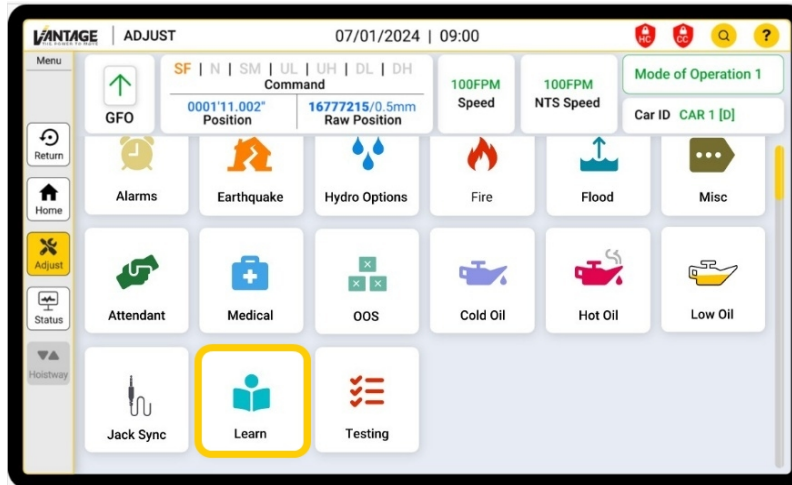

Figure 27: Adjust Screen

3. On the **Learn** screen select the **Motor Drive Learn** option menu.

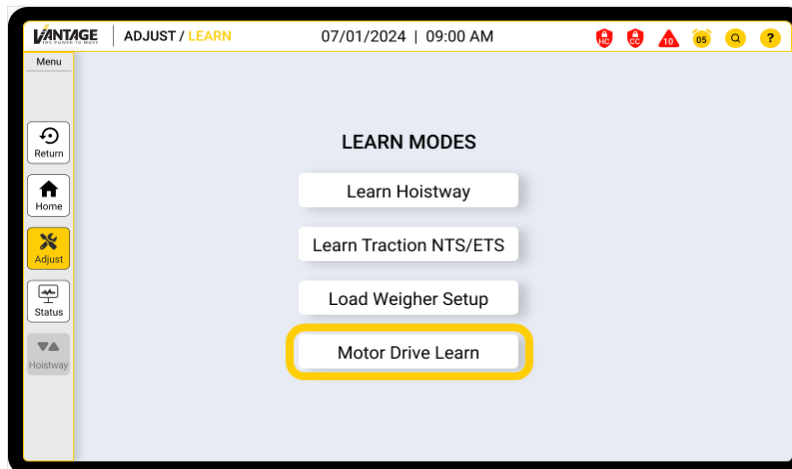

Figure 28: Learn Screen

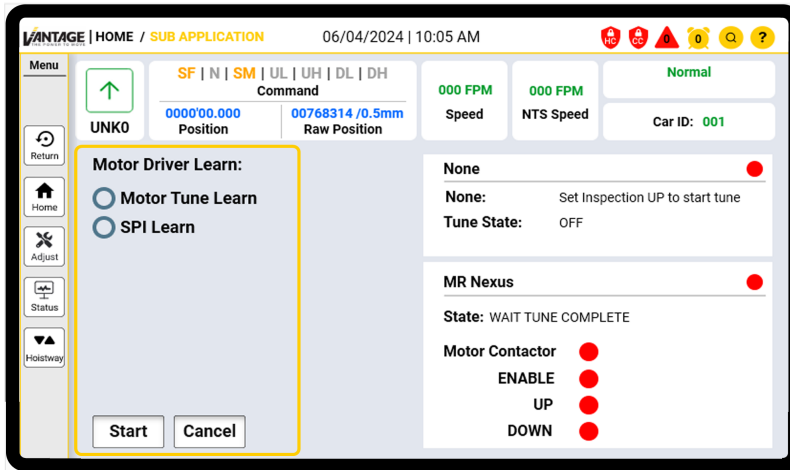

Figure 29: Motor Drive Learn Screen

4. Place the car on MR Inspection mode.
5. On the drive, go to LL Tune Parameters/LL01 Motor Tune. Set the LL01 Motor Tune Parameter to START. If doing SPI learn, set LL05 to START instead of LL01
7. Repeat steps for SPI learn (PM Motor Only) by setting LL05 SPI to START.

### 3.3.6.1 ENCODER SYNCHRONIZATION

To synchronize the encoder direction, from the "Tune Parameter" menu, set LL07 (Encoder Synchronization) to "Start" and follow the keypad instruction. When the drive finishes, the encoder direction has been learned. After making a trial run, verify that the current is not excessive and that the elevator moves in the correct direction. If the encoder synchronization is not successfully completed, follow the directions below to set the motor and encoder direction manually. If changes are made to LE03, the encoder must be relearned.

### 3.3.6.2 MANUAL ENCODER AND MOTOR DIRECTION SETUP PROCEDURE

1. From the **Adjust** screen, navigate to the **Inspection** menu and set the "Inspect Speed = 25".
2. Go to the "Encoder Data" menu on the KEB F6 Drive and select the LE03 (Swap Encoder Channels) parameter and select "Not Inverted". Run the car in the up or down direction.
3. If the car runs in the correct direction, proceed to the next step. If the car runs in the opposite direction, change LE03 parameter to "Inverted Rotation". If LE03 is already set to "A-B Swapped", then change the parameter to "A-B swap & inverted direction".
4. If the motor oscillates or takes off abruptly, change LE03 to "A-B Swapped". If LE03 is already set to "Inverted Rotation", then change the parameter to "A-B swap & inverted direction". Check the run direction again and repeat this step.
5. Select the **Home** screen on the drive's LCD display and then run the car again. Verify that the car runs in the correct direction and the current is less than the full load amps. If so, then the encoder synchronization is complete. If the car moves in the correct direction but the current is greater than the full load amps, then again go to the "Encoder Data" menu and select the LE03 (Swap Encoder Channels) parameter and change the parameter to "A-B Swapped". If LE03 is already set to "Inverted Rotation", then change the parameter to "A-B swap & inverted direction". Repeat this process until the correct motor and encoder directions are correct.

## 3.3.7 CHECK INSPECTION SPEED - TRACTION

From **Adjust** screen, navigate to the "Inspection" menu and set the "Inspect Speed = 25". During controller testing at the factory, the drive is setup to run on an un-rope machine so the gain adjustments might be set too low. Set the gain adjustments to the default values and then follow the gain adjustments for the "LC Control Settings" parameters in the KEB Combivert F6 Elevator Drive Technical Manual.

Run the elevator on inspection and verify that there is less than full load current draw on the KEB LCD "Home" display. If not then relearn the encoder. Press the "EN" + "UP" inspection button and verify motor is rotating in the up direction, and then press the "EN" + "DN" inspection button and verify that the motor is rotating in the down direction. With a hand held tachometer, check the speed of the elevator while running on inspection. The elevator should be running at 25 fpm. Adjust the speed of the car by changing LN01 (Traction Sheave Diameter) parameter in the "Machine Data" menu. Decreasing the Sheave Diameter will increase the speed of the car and vice versa.

UI **Home** screen and monitor the Speed feedbacks. While running on inspection, monitor the controller demand speed "cmd" and the speed feedback "Speed" and "NTS Speed". These values should both display 25.

If the demand and velocity feedback on the UI do not match but the speed on the hand held tachometer and on "cmd" and the Drive feedback all read 25 fpm (within +/- 2 fpm), , contact Technical Support.

### 3.4 SYSTEM COMPONENTS INSTALLATION AND WIRING

---

This section covers top of car, COP, hoistway and hall network installation.

#### 3.4.1 TOP OF CAR BOX INSTALLATION AND WIRING

---

The Nexus™ Cartop box is typically permanently attached to the crosshead using Unistrut and clamps. Survey the cartop and determine the best quadrant for mounting, setup and ease of wiring to door operator(s), load weighing devices, positioning system, fans and cab accessories to the cartop box. Consider clearance requirements for inspection station. Once the Cartop box has been installed, wire the top of car devices, referring to Cartop I/O in the prints for wiring instructions.

#### 3.4.2 COP INSTALLATION AND WIRING

---

Refer to the COP panel provider and cab manufacturer for any special installation instructions if using a pre-wired COP panel. Make Cartop to COP connections, referencing the Car Operating Panel sheet of the Job Specific prints.

COP connects to the car top via Cat5 cable (or discrete if preferred) as noted on page 8 and 10 of the schematics. The Cat5 carries CAN1 H/L, 24VDC power, and SF1-4 signals.

Safety devices in the car (fire stop switch, in-car stop switch, HA switch, in-car inspection switch) are captured on the COP board.

#### 3.4.3 TRAVELER CABLE INSTALLATION AND WIRING

---

Install the Traveler Cable and wiring. Refer to the traveler cable provider and cab manufacturer for any special installation instructions. The traveler cable must be wired to the terminal block in the cartop box. See Travelers page of the Job Specific prints for the terminal block in the cartop box.

#### 3.4.4 RUNNING CAR TOP INSPECTION

---

Once the Machine Room, Car Top, and COP boards are connected, car top inspection can be enabled. All safety devices and door signals monitors are active and must be in the appropriate state. A fault occurs if any of the signals need to be corrected. Once all the faults are cleared, use the Inspection station and enable CT Inspection using the enable switch. On the **Home** screen, the mode of operation shows CT Inspection. The Enable and UP/DOWN buttons on the inspection station can be used to run the elevator.

Doors can be controlled with the Door open and Door close buttons.

Car doors can be bypassed by setting the Car Bypass Switch to CAR BYPASS on the MR board

Hall doors can be bypassed by setting the Hall Bypass Switch to HALL BYPASS on the MR board



If the hoistway has not been learned or landing system not installed, it may be necessary to bypass landing system feedback in the **Adjust > Inspection Menu** to clear any Landing system/NTS/TSRD/Position Limit faults.

## 3.4.5 LANDING SYSTEM INSTALLATION

The following instructions apply to a Kubler landing system.

1. Select a hole depending on the existing rail.

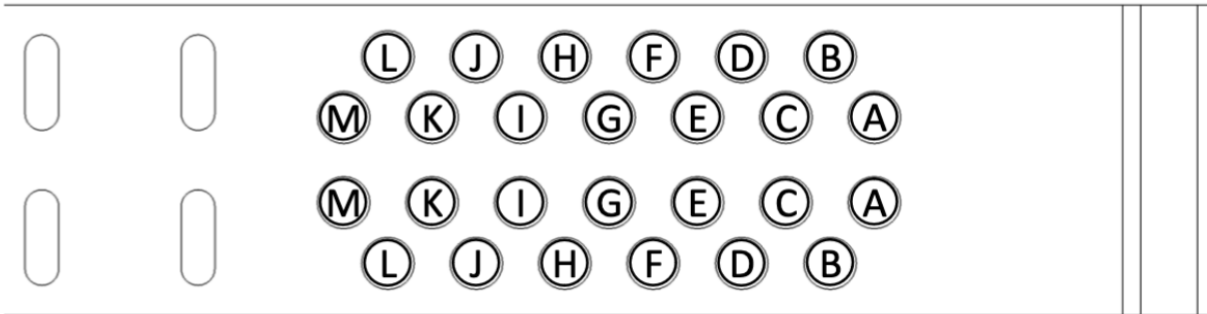

Figure 30: Rail Hole Patterns

Table 3: Rail Hole Settings

	A	D	E	F	I	J	K	L	M
Rail Type	T45 T50	T75-3	T78 T82	T89 T90	T114	T125 T127-1	T127-2	T140-1 T141-2	T140-3

2. Screw counter-screw through rail fastening with claw screw by hand.
3. On the upper rail fastening, attach the code tape by turning the eccentric part away from the bend.

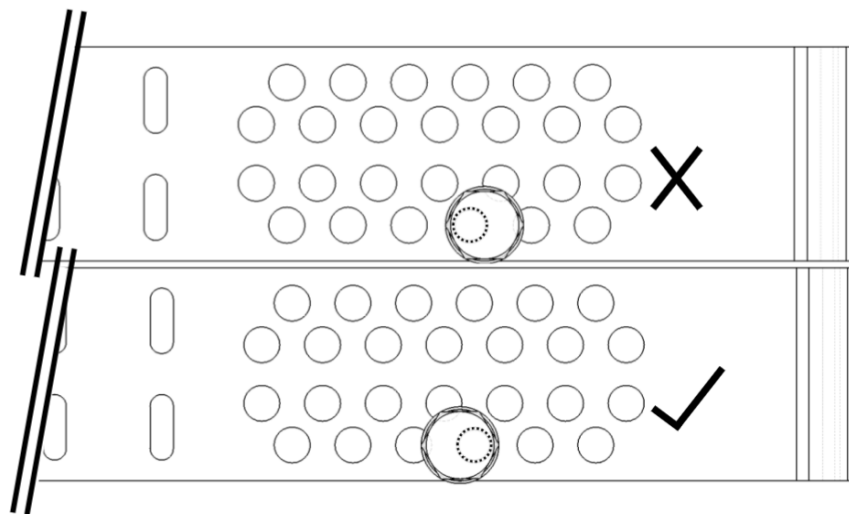
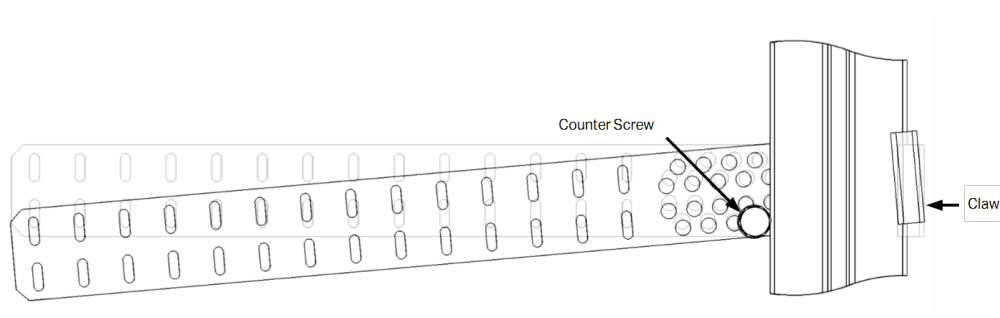

Figure 31: Rail Fastener Eccentric Orientation

4. Do the same for the lower rail.
5. Attach the upper rail fastening to the lift rail at the bend and turn until the rail fastening is in contact with the lift rail.



**Figure 32: Claw Screw Eccentric Head Turned Away from Rail**

6. Lower the rail fastening so that the claw screw rests against the lift rail. The rail fastening now holds itself in the given position.
7. Tighten the claw screw and counter screw by turning them in the same direction (anticlockwise) at the same time. The claw screw now "claws" into the winding rail and the rail fastening aligns itself at right angles to the winding rail. Ensure the two pieces are perpendicular.
8. To lock the upper rail fastening, first ensure that the rail fastening is in contact with the lift rail (see the arrows below).

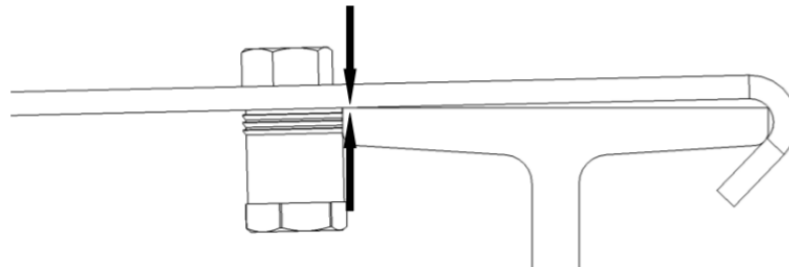

**Figure 33: Selector Rail Bracket Contact Point**

9. Tighten the counter screw to a torque of 33.19–36.87 lb-ft. (40–50 Nm).
10. Attach the code tape.

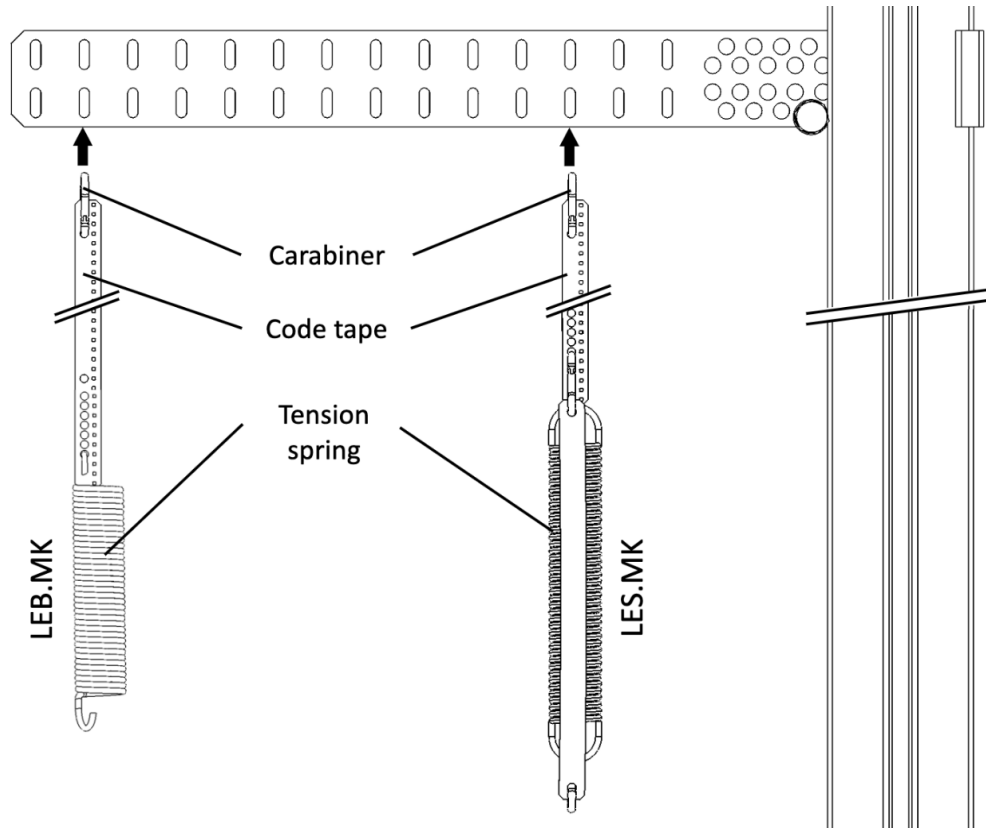

*Figure 34: Attaching Tape to Upper Selector Rail Bracket*

Detailed view: LES.MK

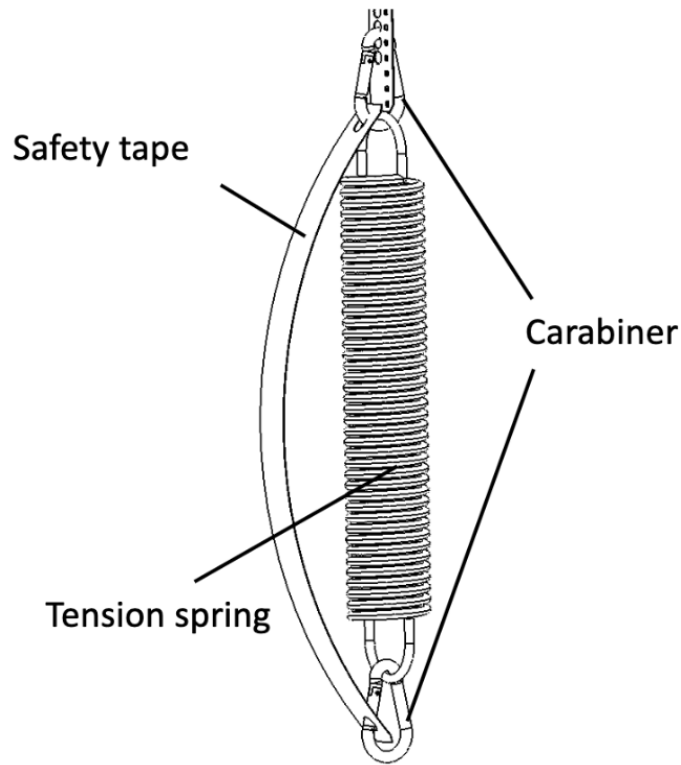

*Figure 35: Selector Tape Spring Tensioner Assembly*

11. Hook in the lower rail fastening. Attach the lower rail fastening to the lift rail at the bend and turn until the rail fastening is in contact with the lift rail, as in Step 5.
12. Lower the rail fastening so that the claw screw rests against the lift rail. The rail fastening now holds itself in the given position.
13. Attach and pretension the spring. Attach and pretension the spring (preload spring to 11.24 - 22.48 lb-ft. (50-100N)) by pushing the rail fastening downwards, which corresponds to 1.18 - 2.36 in (30-60mm) travel. The carabiner at the bottom must be hooked into the parallel hole as the carabiner at the top.

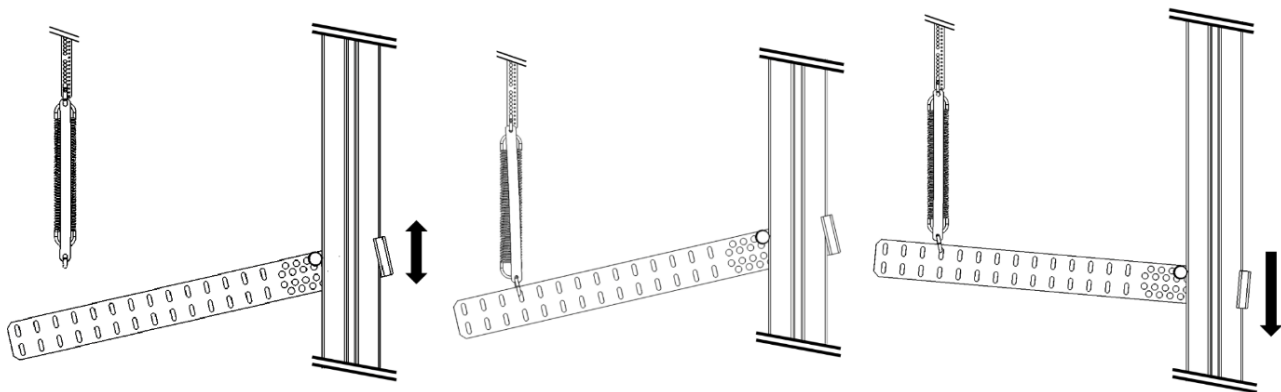

*Figure 36: Attaching the Selector Tape to the Lower Selector Rail Bracket*

14. Position the suspended rail fastening along the rail so that the carabiner on the tension spring can be hooked into one of the suspension holes without tension.
15. Tighten the claw screw and counter screw by turning them in the same direction (anticlockwise) at the same time. The claw screw now "claws" into the winding rail and the rail fastening aligns itself at right angles to the winding rail. Ensure the two pieces are perpendicular.
16. To lock the lower rail fastening, first ensure that the rail fastening is in contact with the lift rail, as in step 8.
17. Tighten the counter screw to a torque of 33.19–36.87 lb-ft. (40–50 Nm).

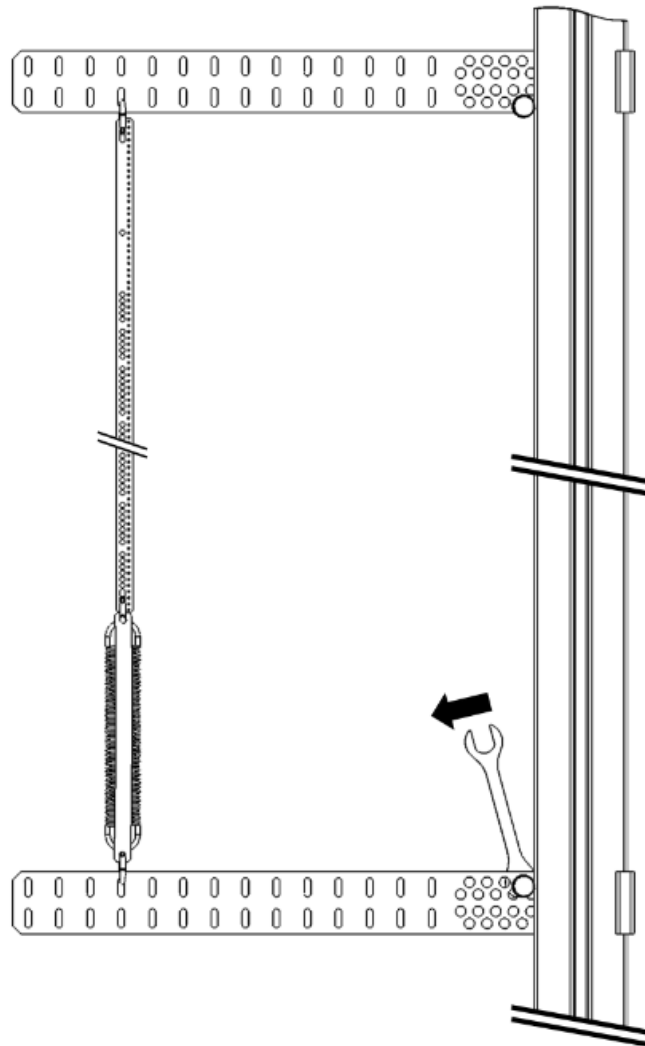

*Figure 37: Tightening the Eccentrics on the Selector Rail Brackets*

18. Install sensor according to sensor instructions.

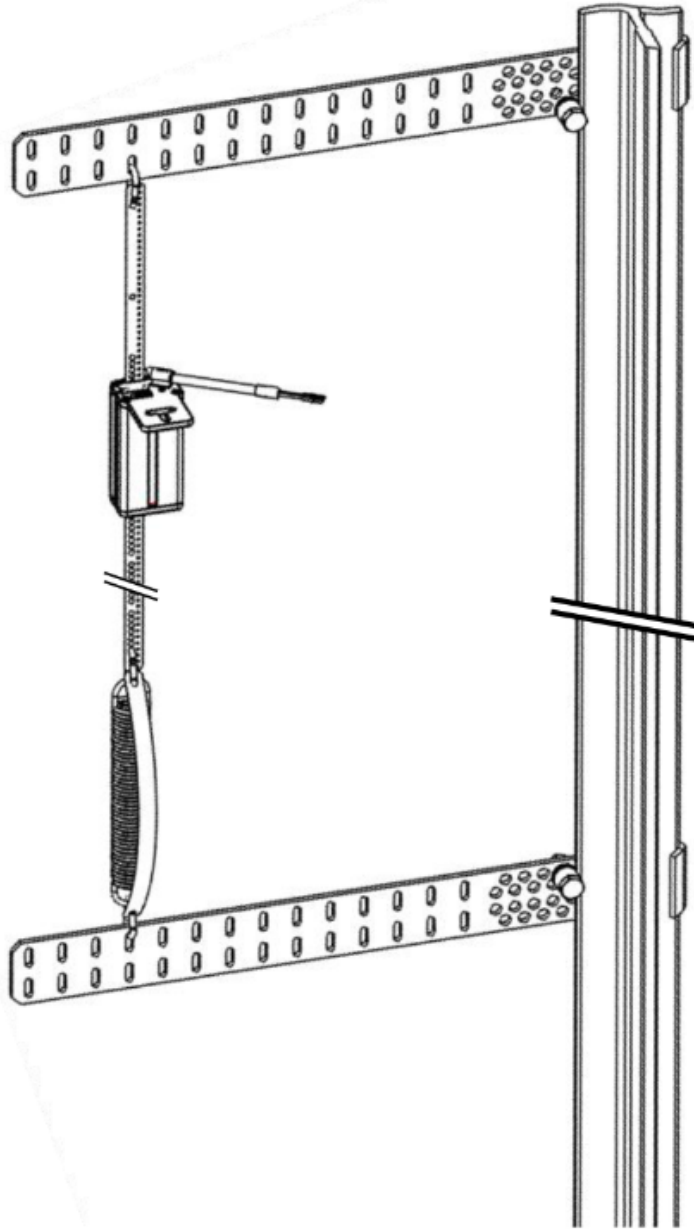

*Figure 38: Illustration of Selector Sensor Head in Contact with the Selector Tape*

## 3.4.5.1 LANDING SYSTEM INSTALLATION VERIFICATION

---

Once the sensor head is mounted to the car, feed the tape through it. Verify installation by running the car Up/Down the hoistway to ensure there's no excessive rubbing/friction between the tape and sensor. Verify the sensor is clear of all obstructions. Verify proper sensor functioning by observing position feedback changes during movement on the **Home** screen.

## 3.4.6 HOISTWAY WIRING

---

Install electrical wiring for all components and CAN bus wiring for all boards that need to communicate with the system.

### 3.4.6.1 MECHANICAL SWITCHES AND PERIPHERALS WIRING

---

While wiring switches and peripherals, verify that wiring meets all relevant AHJ regulations and standards.

#### 3.4.6.1.1 SAFETY CIRCUIT

---

Hoistway and MR safety devices are wired and monitored on independent 120VAC inputs. Each input is redundantly monitored by an independent secondary safety processor.

The following devices are wired to the MR board. If not present, they must have a permanent connection to the input. Confirm code compliance prior to completing a permanent connection.

- **PIT**: Pit switch – AC input 09 on the MR board.
- **BUF**: Buffer Switch – AC input 10 on the MR board.
- **BFL**: Bottom Final Limit – AC input 11 on the MR board.
- **TFL**: Top Final Limit – AC input 12 on the MR board.
- **RG**: Rope Brake Contact – AC input 13 on the MR board.
- **GOV**: Governor Switch – AC input 14 on the MR board.

#### 3.4.6.1.2 DOOR LOCKS

---

Hall locks are separated into 4 inputs for monitoring.

- **LTA**: Lock Top Access – wired to AC input 01 on the MR board.
- **LBA**: Lock Bottom Access – AC input 02 on the MR board
- **LCKF**: Locks Front – wired to AC input 03 on the MR board.
- **LCKR**: Locks Rear – wired AC input 04 on the MR board.

#### 3.4.6.1.3 ACCESS SWITCHES

---

Access switches are monitored on MR board inputs AC05 to AC08.

- **ABUP**: Access Bottom Up – Wired to AC input 05 on the MR board.
- **ABDN**: Access Bottom Down – Wired to AC input 06 on the MR board.
- **ATUP**: Access Top Up – Wired to AC input 07 on the MR board.
- **ATDN**: Access Top Down – Wired to AC input 08 on the MR board.

#### 3.4.6.2 HALL NETWORK

---

The hall board network provides hall call, lantern and chime functionality.

### 3.4.6.2.1 HALL NETWORK WIRING

Simplex:

Hall lanterns connect to MR board CAN3 when present and are daisy chained.

All other Hall functionality (Hall calls, Swing, Medical, etc.) are connected to the MR board CAN4.

Group:

Hall Lanterns connect to MR board CAN3 when present and are daisy chained.

If a Riser board is present, it communicates with all the cars and connects to the CAN4 group network of the MR board.

All other Hall functionality (Hall calls, Swing, Medical, etc.) connects through CAN2/3 of the Riser board.



Termination is vital when CAN is used and must be set based on the Job Specific configuration. The first and last node of each network chain must be terminated.



MR CAN 1,2 and 3 are automatically terminated on the MR board.

### 3.4.6.2.2 ADDRESSING HALL BOARDS

Each Hall board is uniquely identified using 3 rotary switches and a single DIP switch (Which designates Front or Rear opening). Multiple boards can be daisy chained together on a CAN network.

The unique identity of a board comes from three board settings:

- Function rotary switch setting (can be 0 thru 9)
- Landing number, derived from rotary switches: (Switch 2\*10) + Switch 3
- Single DIP switch for Door Side (OFF: front(F) / ON: rear(R))

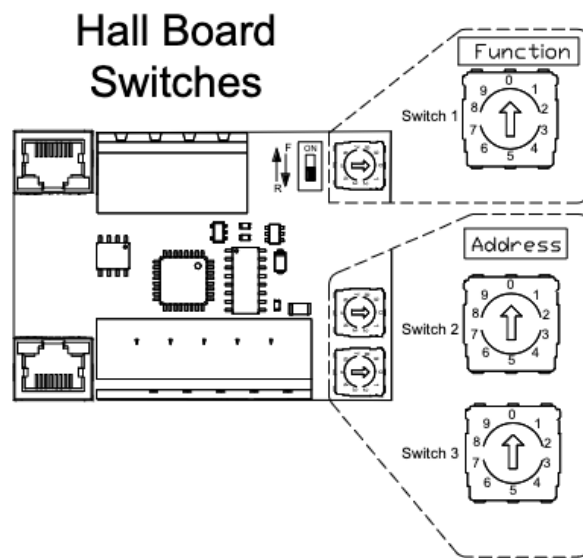

Figure 39: Hall Board Rotary Switch Settings

A set of hall boards on a network can be defined to have some unique shared behavior depending on controller configuration. Hall boards are configured using the board's Function switch setting. For example, all boards with Function setting 0 can be defined to call only cars 1 and 2, while all boards with Function setting 1 can be defined to call only cars 3 and 4.

The floor number determines the landing. The lowest served landing is numbered 1. The 2-position "Door Side" switch determines if the board is for calls/arrivals serving the front car door, or rear car door. Hall boards send errors, up button, down button, and lantern/output state updates to the hall master software running on the controller at regular intervals. The hall master processes the data from all the hall boards and determines which ones are valid. It provides feedback that the call is latched by sending commands to the hall board that the lantern for the call direction should turn ON. The hall master sends lantern commands at regular intervals to all active hall boards in the system to maintain communication. Due to call request propagation delays, hall boards always illuminate call buttons locally long enough to receive feedback from the controller, at which point the button light is set according to feedback.

### 3.4.6.2.3 VERIFY HALL NETWORK

For diagnostics, the hall boards self-report errors. Verify that the heartbeat LED illuminates once a second to show the device is operational.

Hall boards connected to the system can be detected using the **Hall Board** screen in the **Status** menu. Touch the **Hall Board** icon to enter the **Hall Board** screen.

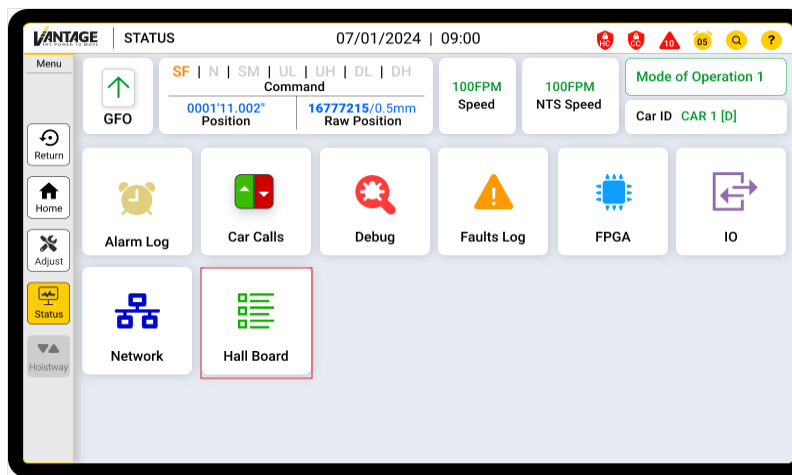

Figure 40: Status Screen

Touch **Scan** for the controller to search the system for hall boards

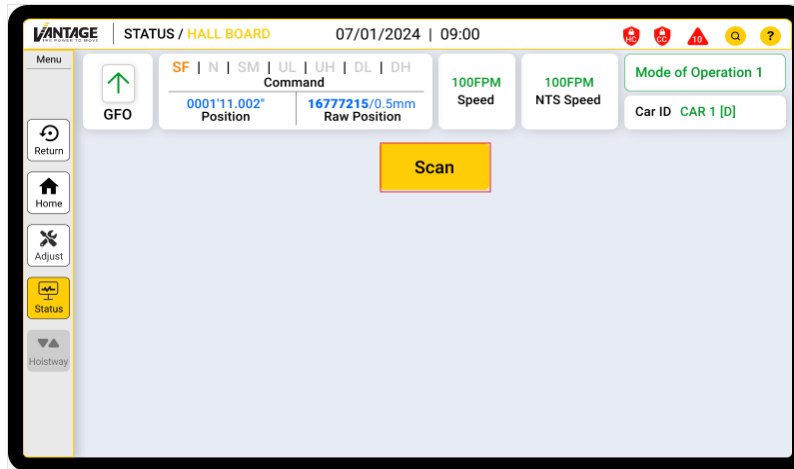

Figure 41: Hall Board Status Screen

This displays a list of hall boards communicating on the hall and group networks, MR CAN3 and CAN4.

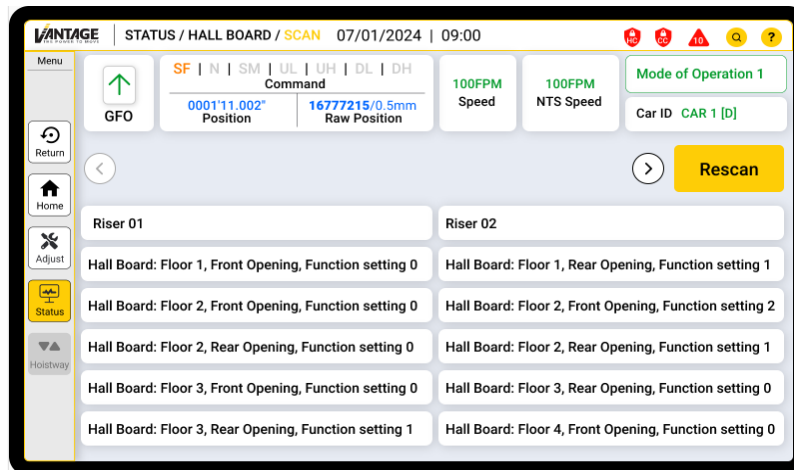

Figure 42: Hall Network Scan Example

## 3.5 LEARNING THE HOISTWAY

The controller needs to learn the positions of the floor landings. This process can be completed by individually learning each landing position, or all landings at once by setting a distance between landings.

1. To begin the learn process, turn on MR DIP switch 4 (sets the Mode of Operation to Learn), then in the Adjust menu, select the Learn icon.

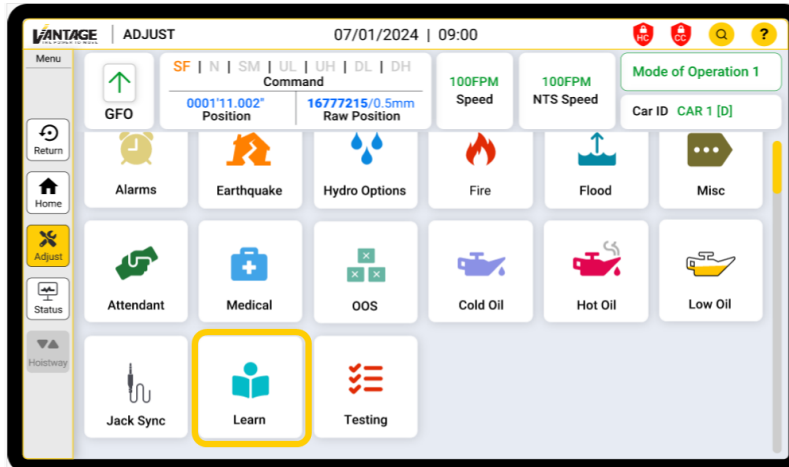

Figure 43: Adjust Screen

2. Next, select Learn Hoistway.

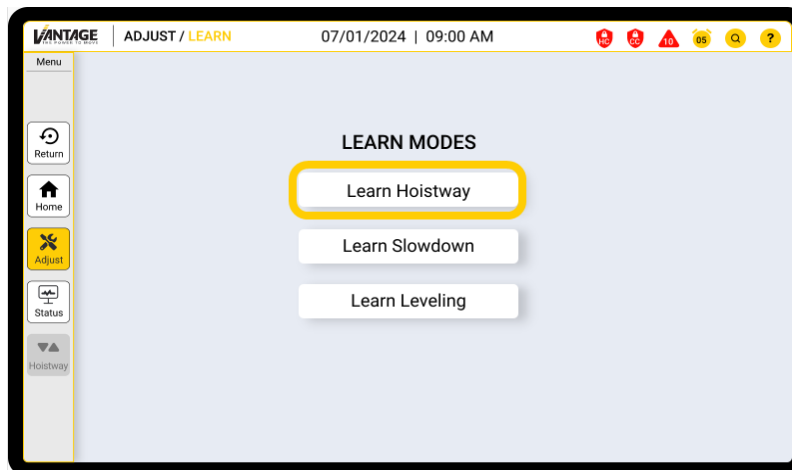

Figure 44: Learn Selection Screen

3. Configure the Learn Hoistway process.

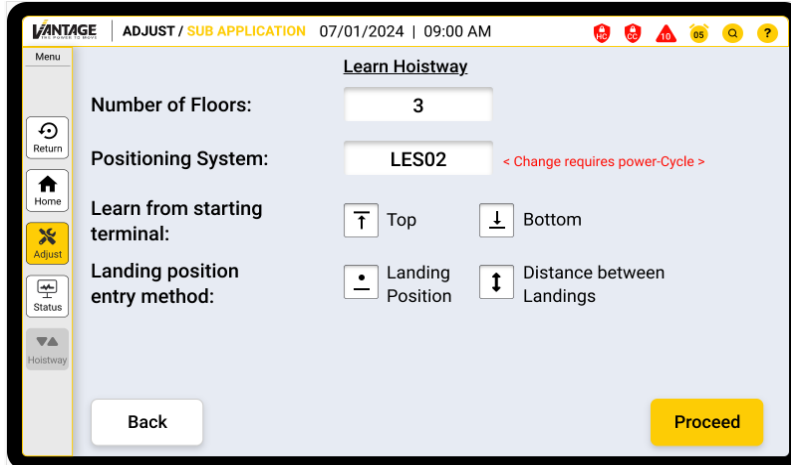

Figure 45: Hoistway Learn Example

- Number Of Floors: Number of floors in the hoistway for which landing positions to learn. If this parameter value is changed, the learn process can proceed without reset, but the car cannot be moved while leaning (enter position values manually).
- Positioning System: The car position sensor system used for the Job Specific. If this value is changed, the learn process cannot proceed, and must restart after a controller reset.

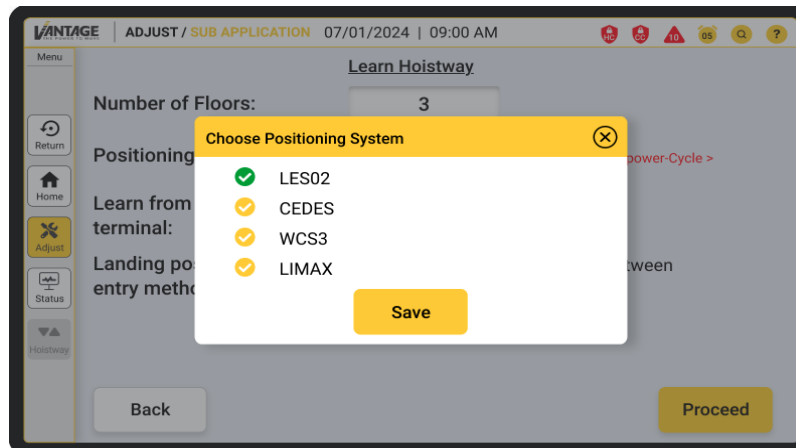

Figure 46: Hoistway Learn Position System Selection Example

- Learn From Start Terminal (Top / Bottom): The hoistway learn process must start from either the bottom or top terminals. select either Top or Bottom Icons.
- Landing Position Entry Method (Landing Position/Distance Between Landings): The Landing Position option learns each landing position value individually. The Distance Between Landings option requires first learning one of the terminal landing positions, then setting the remaining landings by using a single distance between landings value.

## 3.5.1 LEARN BY LANDING POSITIONS

To learn landing positions individually, starting from either bottom or top terminal, do the following:

1. In the **Learn Hoistway Configuration** screen select:
  - Learn From Start Terminal: Select Top or Bottom.
  - Landing Position Entry Method: Select Landing Position.
2. Select Proceed, and the display transitions to the following:

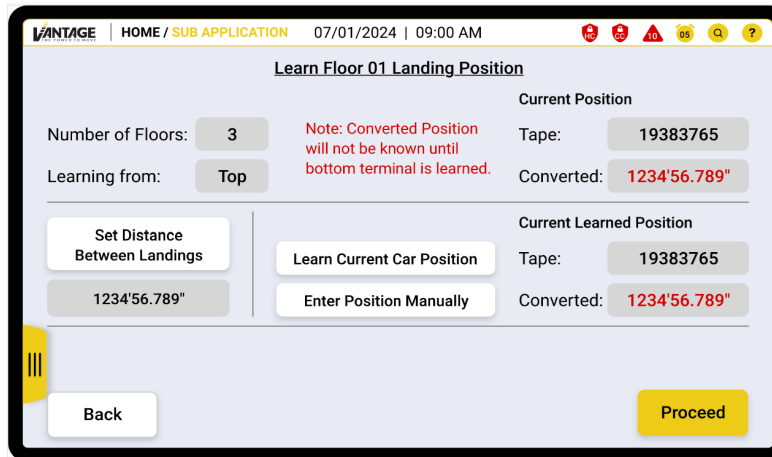

*Figure 47: Hoistway Learn Landing Position Learn Example*

3. Start with learning Floor 1 (the bottom or top terminal). Enter the position either from the car's current position value (selecting Learn Current Car Position), or by manually entering a position value.



Position the car as level as possible as this becomes the center of the 6" virtual Door Zone (DZ).

4. To move the car during the learn, activate any inspection operation, and use the manual mode's run controls to change the car's position. The car's position displays top right under Current Position. The tape value is simply the raw value read of the positioning system sensor. The Converted position is distance in feet/inches from the bottom terminal. (NOTE: This value cannot be determined until the bottom terminal is learned.) The position learned for this floor's landing displays under Current Learned Position.
5. After entering the landing position for this floor, select Proceed. The floor number at the top of the screen changes to 2, set the car level at the next floor and the same landing position entry methods can be repeated to learn this floor's landing position.
6. Repeat the process through the next terminal landing. At this point the Proceed button turns to Finish. Select Finish to save all the landing positions as permanent parameter values.
7. If the learn process is completed successfully, the following message is displayed.

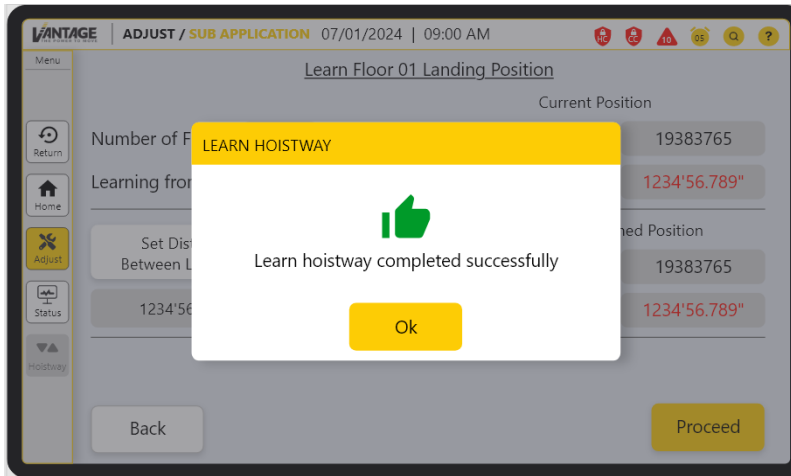

Figure 48: Hoistway Learn Successful Learn Example

8. Touch OK to return to the **Home** screen. Deactivate Learn mode by turning off MR DIP switch 4. NOTE: In the background, the MR board could still be syncing the newly learned floor parameter values with the rest of the system. Do not reset or turn off the controller until the successful popup is displayed
9. A controller power cycle is required after the learn operation is successful.

On a Hydro, The Slowdown distances, NTSD positions, and TSRD position are calculated based on the table below once the learn operation is complete. Slowdown Distance value is calculated from the destination landing position value. DNTS value is set based on offset from the bottom terminal landing position value. UNTS and TSRD values are set based on offset from the top terminal landing position value.

Table 4: Suggested Slowdown and Offset Distances - Hydraulic

Speed (FPM)	Slowdown Distance (in)	UNTS/DNTS Offset (in)	TSRD Offset (in)
0 to 25	6	5	4
>25 to 50	12		
>50 to 75	18	9	7
>75 to 100	24	12	10
>100 to 125	30	21	17
>125 to 150	36		
>150 to 175	42	30	22
>175 to 200	48		

## 3.5.2 NTSD/ETSD LEARN – TRACTION

Before running a traction elevator on normal operation, NTS and ETS learn operation must be completed. During this process NTS and ETS Speeds will be learned.



Changing speed profile characteristics may require a relearn of the NTS and ETS speeds.

To perform a NTS/ETS learn, follow these steps

1. Flip dip switch 4 on the MR board (Mode of operation changes to Learn)
2. Go to Adjust/Edit Parameters/8 BIT and check that parameter 08-127 "NTS position cross check" is not zero. If it is, the learn process will most likely fail.
3. Go to Adjust/Learn
4. Select Learn Traction NTS as shown in figure 36.

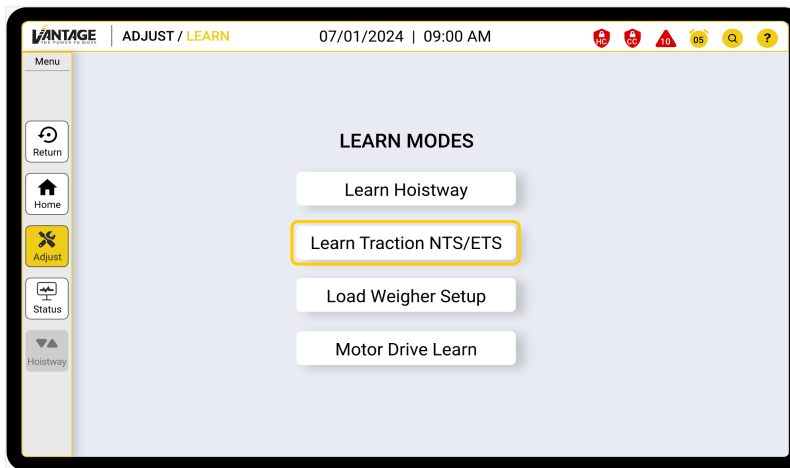

Figure 49: Learn Traction NTS/ETS

4. Select UNTS/UTS or DNTS/DETS Learn by selecting one of the options shown in figure 37.

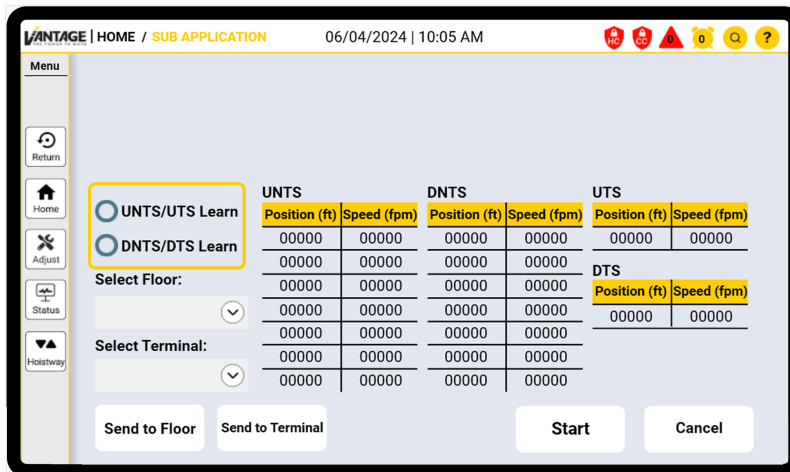

Figure 50: Select one of the highlighted options

- Press the "Start" button to start the learn process. The elevator will start moving if it is at the correct position and the doors are closed. For UNTS/ETS the car must be at floor that is not the top terminal. Contrary to UNTS/ETS, for DTNS/DTS, the car must be at a floor that is not the bottom terminal. Move the car to any floor in the hoistway by selecting a floor on the "Select Floor" or "Select Terminal" list menus. See [Figure 26](#) for reference.

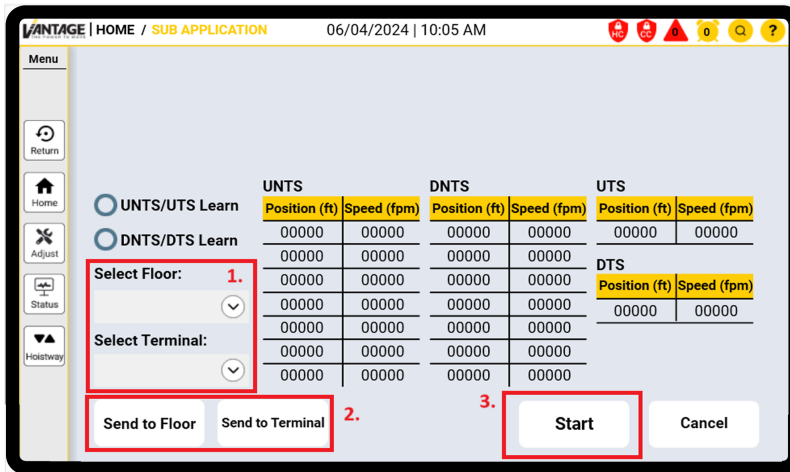

Figure 51: Screen selections

- Once the learn process is complete, please verify that there is at least one non-zero UNTS/DNTS position and speed values. Moreover, ensure that ETS also has non-zero values. If that is not the case, please repeat the UNTS or DNTS learn process.

### 3.6 ADJUSTING

**Adjust** screen allows for changes to be made for functions that are sorted in easy to find phone app like blocks. Each block will have all the options related to the selection title.

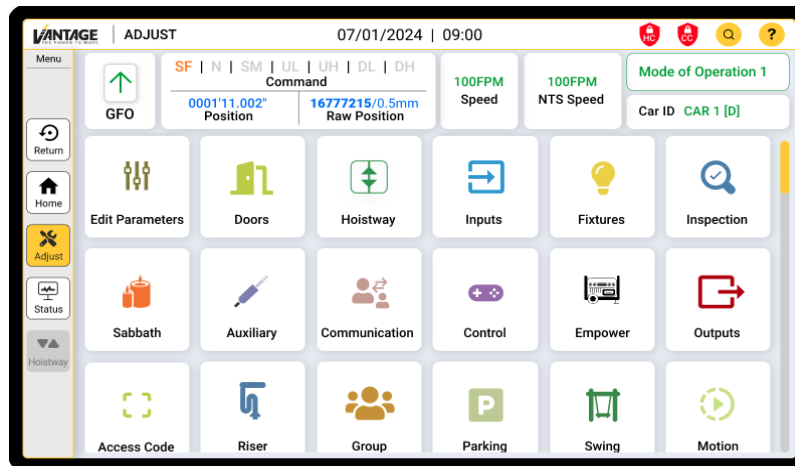

Figure 52: Adjust Screen

## 3.6.1 ADJUST PARAMETERS

Parameters are used to configure and adjust the controller settings.

1. To modify parameters, select **Edit Parameters** on the **Home > Adjust** screen.

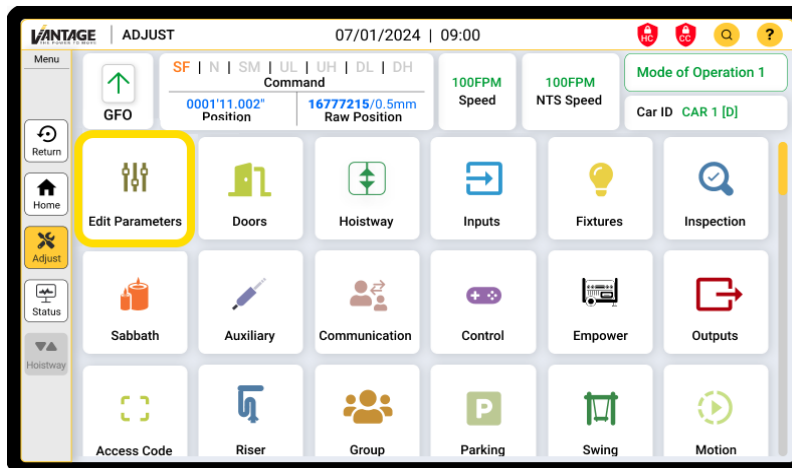

Figure 53: Adjust Screen

Parameters are broken down into groups that allow the user to access and adjust the raw value of all system parameters. Adjustments are done in different ranges depending on the BIT selection.

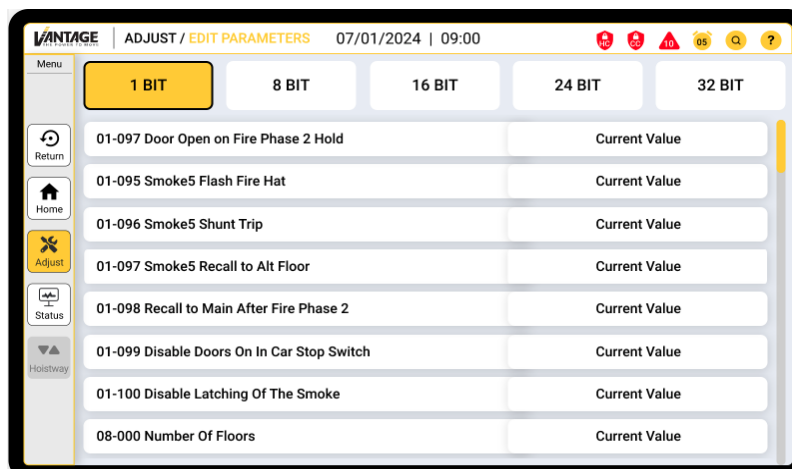

Figure 54: Edit Parameter Screen

2. Select a parameter to bring up the detail screen for that parameter:

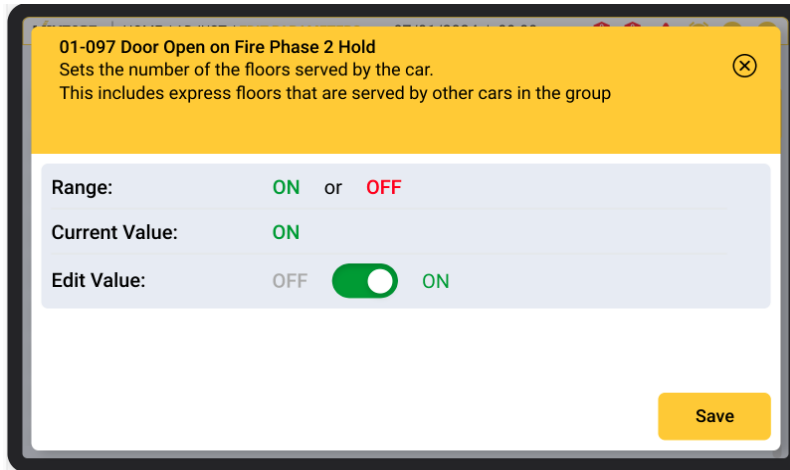

Figure 55: Modify Selected Parameter

Options are as follows:

- Range: Parameter range.
- Current value: The parameter value currently active.
- Edit value: New parameter value selection.

3. Adjust parameters as needed and touch **Save**.

### 3.6.2 ADJUST SLOWDOWN DISTANCE - HYDRAULIC

Slowdown distance is the distance from the destination floor the controller turns off the high-speed valve and transitions to the low-speed valve. To adjust this setting, do the following:

1. Go to **Adjust > Control > Slowdown Distance Down** or **Adjust > Control > Slowdown Distance Up**.

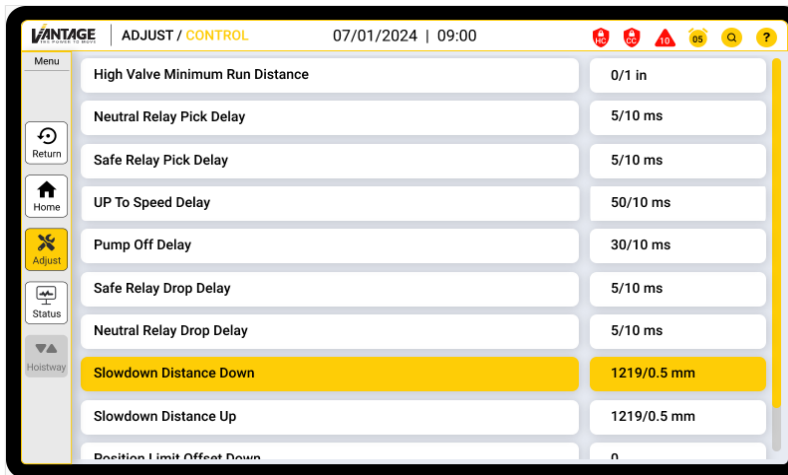

Figure 56: Control Screen

2. This value is an offset from the learned floor position in .5mm counts. The Up and Down slowdowns are set independently.

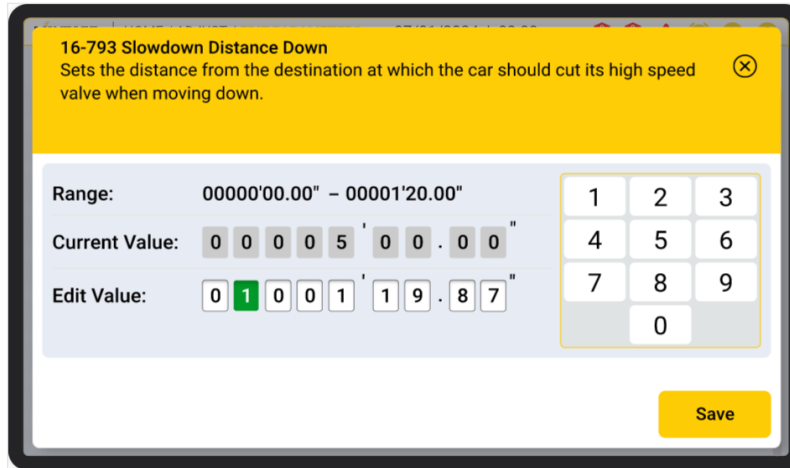

Figure 57: Slowdown Distance Example



Changing slowdown distance activates relearn of the NTS and TSRD positions. Once changed, run the car to the terminals to verify no nuisances tripping occurs.

### 3.6.3 ADJUST NUMBER OF FLOORS

To adjust number of floors, do the following:

1. Navigate to **Adjust > Hoistway** and select Number of Floors.

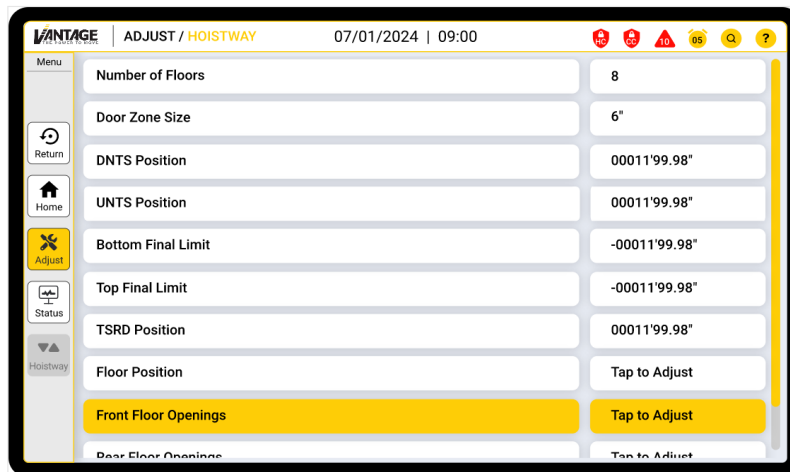

Figure 58: Hoistway Adjustment Screen

2. Select the number next to the **Edit Value** and enter the new value. Touch **Save**. The controller requires a reset once the parameter is changed

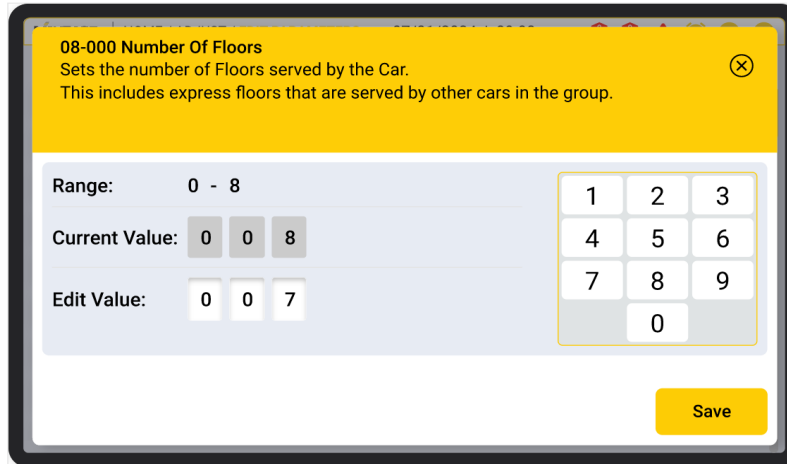

Figure 59: Hoistway Number of Floors Example

### 3.6.4 ADJUSTING INPUTS

1. On the MR UI, navigate to the **Home > Adjust > Inputs** screen. A list of boards appears.

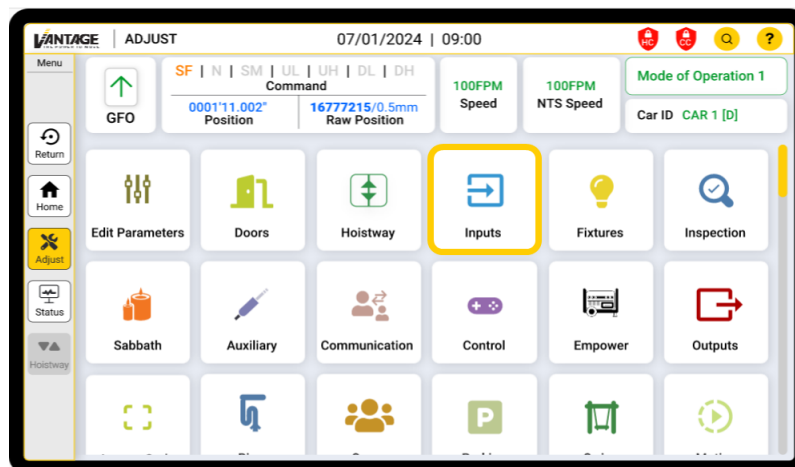
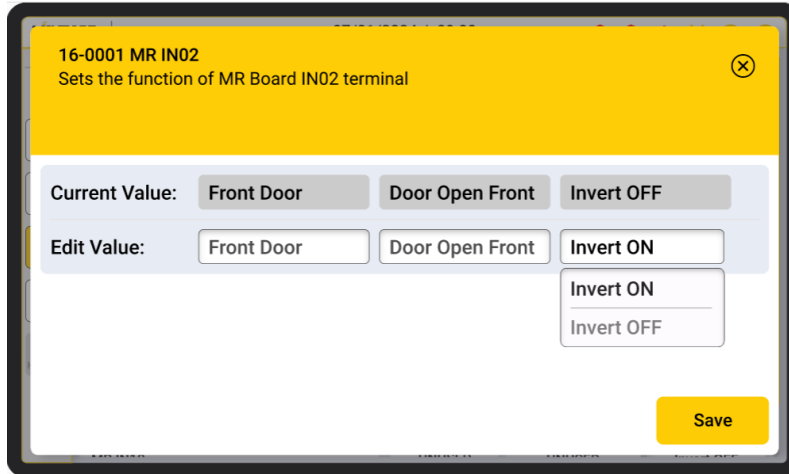

Figure 60: Adjust Inputs Screen

2. Select the board which the input is on. A list of mappable input terminals appears.
3. Scroll the desired input to change. A popup appears, displaying:
  - a. The 16-bit parameter index associated with MR input 02.
  - b. The parameter name associated with the parameter index.
  - c. The **Current Value**.
    - i. The first drop down menu corresponds to the **Input Setup Group** of the currently mapped function. If no function is mapped, it displays **UNUSED**.
    - ii. The second drop down menu corresponds to the Input Setup Index of the currently mapped function. If no function is mapped, it displays **UNUSED**.

- iii. The third drop down menu corresponds to the **Invert Flag** of the currently mapped function.



*Figure 61: Adjusting Input Value Example*

- d. The Edit Value:
  - i. The first drop down menu corresponds to the **Input Setup Group** of the input function to be edited.
  - ii. The second drop down menu corresponds to the **Input Setup Index** of the input function to be edited.
  - iii. The third drop down menu corresponds to the **Invert Flag** of the input function to be edited. Optionally modify the third drop down menu (**Invert Flag**) if the input needs to be changed from **Active Low** to **Active High** or vice versa.
- e. Select **Save**. The input function is mapped to the selected input.

## Section 4 Testing



Every safety precaution, whether specifically stated in this document, must be implemented when installing, adjusting, or servicing elevator equipment. All safety precautions must be followed to ensure the safety of elevator personnel and the public.



The test procedures outlined in this manual provide a guide for elevator personnel to perform the specific tests in this Appendix. These test procedures are not intended to override or circumvent any procedure mandated by the applicable codes and the Authority Having Jurisdiction.



All temporary connections must be removed before placing the elevator in service.



If there are any questions about the procedures for performing these tests with a Nexus™ controller, please contact Vantage toll free at 1 (877) 425-7778 for free technical assistance.

### 4.1 TESTING PROCEDURES

#### 4.1.1 LOW OIL OPERATION

Test this in compliance with ASME A17.1 Section 3.26.9:

- A17.1 3.26.9.1: A means shall be provided to render an elevator on normal operation inoperative if for any reason the liquid level in the tank falls below the permissible minimum. Suitable means include, but are not limited to, the following: (a) direct sensing of the liquid level (b) a pump-run timer. Actuation of the means shall automatically bring the car down to the lowest landing, when the doors are closed.
- A17.1 3.26.9.2: When at the lowest landing, the doors shall comply with the following: (a) For elevators with power-operated doors that automatically close, the door(s) shall open and shall initiate automatic closing within 15 s. (b) For elevators with manual doors or with doors that do not automatically close, they shall be provided with a signal system to alert an operator to close the doors.
- A17.1 3.26.9.3: The car shall then shut down. The means shall require manual reset before returning the car to service. For elevators with power-operated doors, the in-car door open button (s) shall remain operative, but the doors shall not be able to be power-opened from the landing.

##### 4.1.1.1 SIMULATING A LOW OIL CONDITION

**Low Oil** input is monitored by a normally closed dry contact actuated by an external device located in the pump unit. This is fed back to the controller via a 24VDC **Low Oil** input on the MR board.

When the **Low Oil** input is activated, the car aborts its current run (stopping the run in-flight at its current point) and returns to the bottom landing, where it opens its doors and initiates the closing sequence within 15 seconds of the doors becoming fully open. The car then goes out of service. The in-car door

open button remains operative, but no other functions cause the door to re-open, including hall calls at the landing or Manual Door Open buttons for Freight doors located in the hallway.

## By Input Assertion

1. Place the controller in automatic **Normal** operating mode. On the **Home** screen, **Operation Mode** displays **Normal**.
2. Map the **Low Oil** input to the controller (see **Inputs** on the **Home > Adjust** screen) if the input is not already mapped.
3. Set the input active. On the **Home** screen, **Operation Mode** displays **Low Oil**.
  - a. If the car is not moving and in door zone:
    - i. If the car is not at the bottom landing, the car recalls to the bottom landing.
    - ii. When the car reaches the bottom landing and is in door zone, the door(s) open.
    - iii. The **UI active** fault displays **158 Low Oil** Input and the fault LEDs blink.
    - iv. The door(s) close within 15 seconds. DOB is operative.
  - b. If the car is moving up:
    - i. The car stops and recalls to the bottom landing.
    - ii. When the car reaches the bottom landing and is in door zone, the door(s) open.
    - iii. The UI active fault displays **158 Low Oil** Input and the fault LEDs blink.
    - iv. The door(s) close within 15 seconds. DOB is operative.
  - c. If the car is moving down:
    - i. The car recalls to the bottom landing.
    - ii. When the car reaches the bottom landing and is in door zone, the door(s) open.
    - iii. The UI active fault displays **158 Low Oil** Input and the fault LEDs blink.
    - iv. The door(s) close within 15 seconds. DOB is operative.
4. To remove the car from **Low Oil**, set the input inactive. Then press the MR fault reset button.
  - a. On the **Home** screen, **Operation Mode** displays **Normal**.
  - b. The active fault clears, and the fault LEDs turn off.

## By Timer

1. Place the controller in automatic **Normal** operation mode. On the **Home** screen, **Operation Mode** displays **Normal**.
2. Set the parameter 8-41 General Pump Time Limit to 30 (see Parameters).
  - a. To test while running up, place a car call several floors above the cars current position (far enough for the run timer to elapse within 30 seconds). As the car moves up to service the call, the run timer expires after 30 seconds. On the **Home** screen, **Operation Mode** displays **Low Oil**.
  - b. The car stops and recalls to the bottom landing.
  - c. When the car reaches the bottom landing and is in door zone, the door(s) open.
  - d. The UI displays an active **159 Low Oil Timer** fault and the fault LEDs blink.
  - e. The door(s) close within 15 seconds. DOB is operative.
  - f. To test while running down, place a car call several floors below the cars current position (far enough for the run timer to elapse within 30 seconds). As the car moves down to service the call, the run timer expires after 30 seconds. On the **Home** screen, **Operation Mode** displays **Low Oil**.
  - g. The car recalls to the bottom landing.
  - h. When the car reaches the bottom landing and is in door zone, the door(s) open.
    - i. The UI active fault displays **159 Low Oil Timer** and the fault LEDs blink.
    - j. The door(s) close within 15 seconds. DOB is operative.

- k. To remove the car from **Low Oil** mode, press the MR FAULT RST button.
- l. **Operation Mode** displays **Normal**.
- m. Active fault clears, and the fault LEDs turn off.
- n. Set parameter 8-41 General Pump Time Limit back to its original value.

#### 4.1.1.2 RESETTING LOW OIL

---

Low Oil requires a manual reset which means the fault latches through a power cycle of the controller and only clears by pressing the fault reset button.

#### 4.1.2 HOT OIL

---

In compliance with ASME A17.1 Section 3.26.6.5

##### 4.1.2.1 SIMULATING HOT OIL UNDER NORMAL CONDITIONS

---

1. Place the controller in automatic **Normal** operation mode. On the **Home** screen, **Operation Mode** displays **Normal**.
2. Map the **Hot Oil** input to the controller (see Inputs on the **Home > Adjust** screen) if the input is not already mapped.
3. Set the input inactive. On the **Home** screen, **Operation Mode** displays **Hot Oil**.
4. If the car is not moving and in door zone, and if the car is not at the bottom landing, the car recalls to the bottom landing.
5. Once the car is at the bottom landing and is in the door zone, the door(s) open.
6. The UI displays an active **161 Hot Oil** fault. The fault LEDs blink.
7. The door(s) close within 15 seconds. DOB is operative.
8. If the car is moving up, the car stops and recalls to the bottom landing.
9. When the car reaches the bottom landing and is in door zone, the door(s) open.
10. The UI displays an active **161 Hot Oil** fault, and the fault LEDs blink.
11. The door(s) close within 15 seconds. DOB is operative.
12. If the car is moving down, the car recalls to the bottom landing.
13. When the car reaches the bottom landing and is in door zone, the door(s) open.
14. The UI displays an active **161 Hot Oil** fault and the fault LEDs blink.
15. The door(s) close within 15 seconds. DOB is operative.
16. To remove the car from **Hot Oil**, set the input inactive. Then press the MR fault reset button.
17. On the **Home** screen, **Operation Mode** displays **Normal**. The active fault clears and fault LEDs turn off.

## 4.1.2.2 RESETTING HOT OIL

After the condition is cleared, press the fault reset button on the MR Board.

## 4.1.3 VALVE PRESSURE RELIEF TEST

In compliance with \_\_\_\_\_

1. Place machine room DIP switch 5 in the up position to capture the car and turn the automatic doors off
2. Place a car call from the controller **Hoistway View** to the top landing.
3. Place the car on Machine Room Inspection.
4. Navigate to **Adjust > Inspection > Parameter 1-33 Bypass Landing System Feedback** and set to **ON**.
5. Run car up on inspection until reaching the stop ring and pressure test is performed.

## 4.1.4 NORMAL TERMINAL STOPPING DEVICE (NTSD)

In compliance with ASME A17.1 – Section 3.25.1

This test verifies failure of Normal means to slowdown the car into a terminal landing.

Upper and lower normal terminal stopping device is used to detect the position of the car and slow and stop it automatically, at or near the top and bottom terminal landings, with any load up to and including rated load in the car from any speed reached in normal operation. Tests can be run by adjusted the downward normal travel speed (DNTS) or upward normal travel speed (UNTS) position towards the opposite terminal.

To test **NTS** in the **UP** direction:

1. Place car at the bottom terminal
2. Capture the car by turning DIP5 ON (**UP**) in the MR. This takes the car out of the group. Capture Alarm displays when the car is captured.
3. Go to **Adjust > Testing**.

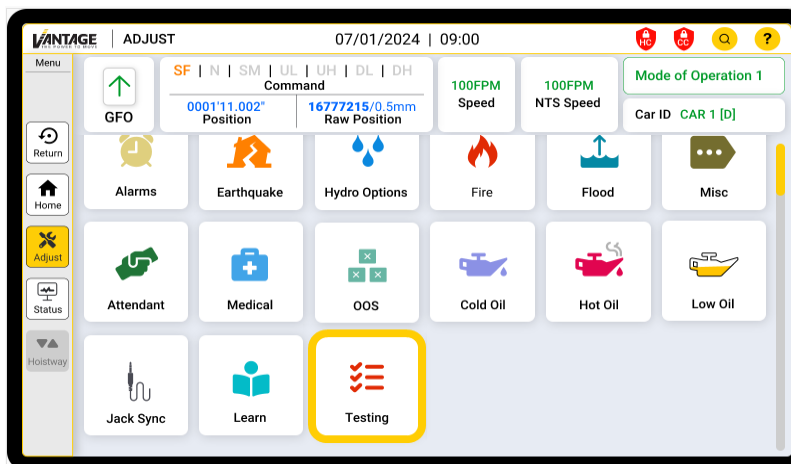

Figure 62: Compliance Testing Icon Screen

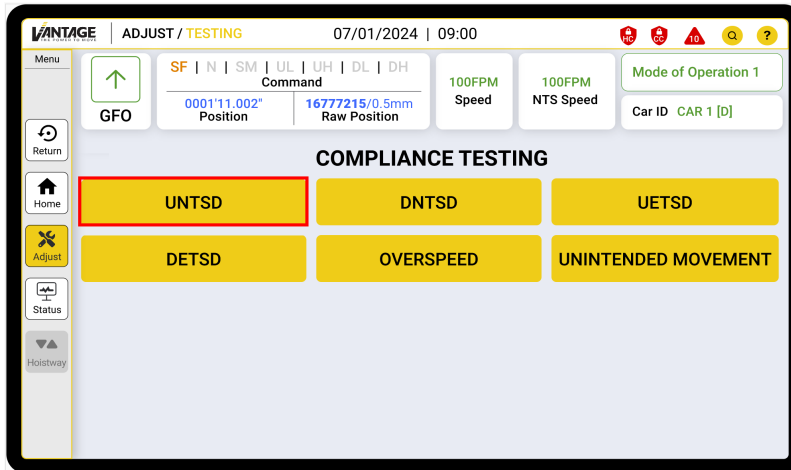

Figure 63: Compliance Testing Selection Screen - UNTSD

4. If the car is not at the terminal landing, touch the Call Car to Terminal button.
5. Follow on-screen instructions to begin the test.
6. Once **UNTS D** test passes, the success screen pops up.

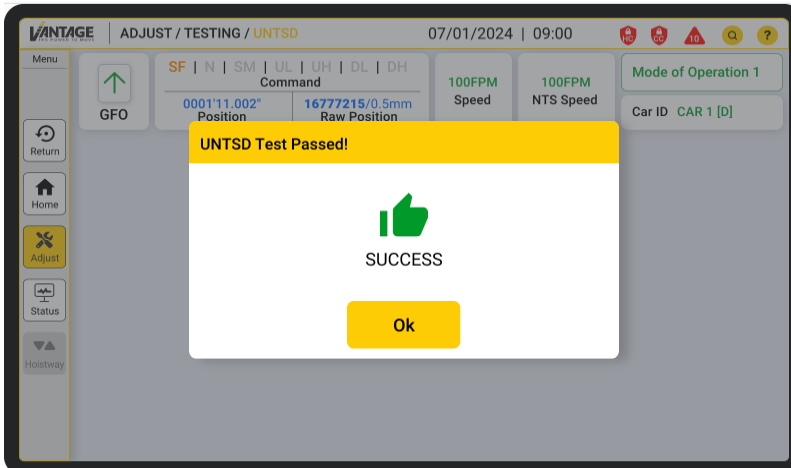

Figure 64: Compliance Testing Completion Message

7. Turn off DIP7 on the MR.

To test **NTS** in the **Down** direction:

1. Place the car at the top terminal.
2. Capture the car by turning DIP5 ON (**UP**) in the MR. This takes the car out of the group. Capture Alarm displays when the car is captured.
3. Go to **Adjust > Testing**.

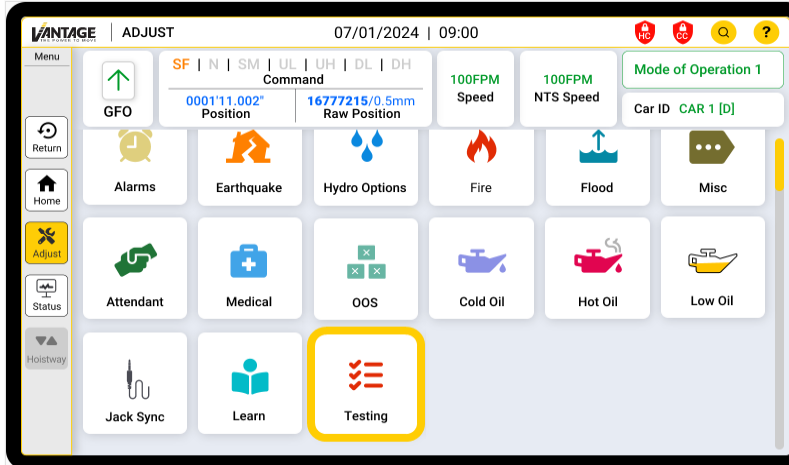

Figure 65: Compliance Testing Icon Screen

4. Select **DNTSD** from the **Compliance Testing** list screen.

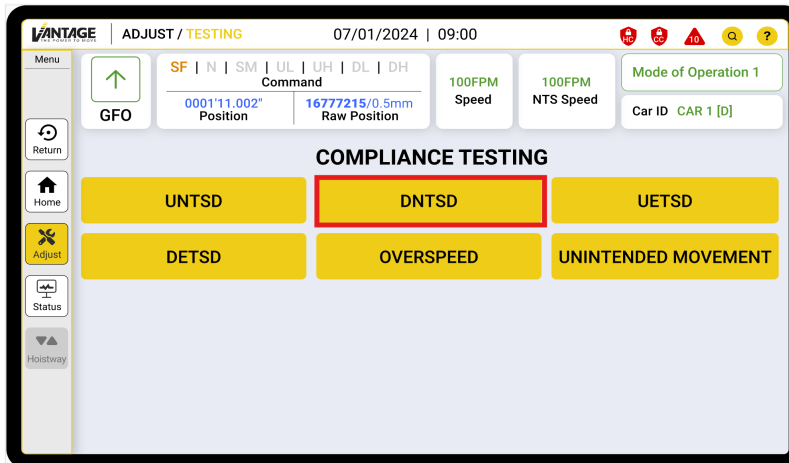

Figure 66: Compliance Testing Selection Screen - DNTSD

5. If the car is not at the terminal landing, touch Call Car to Terminal.
6. Follow on-screen instructions to begin the test.

7. Once **DNTSD** test passes, the success screen pops up.

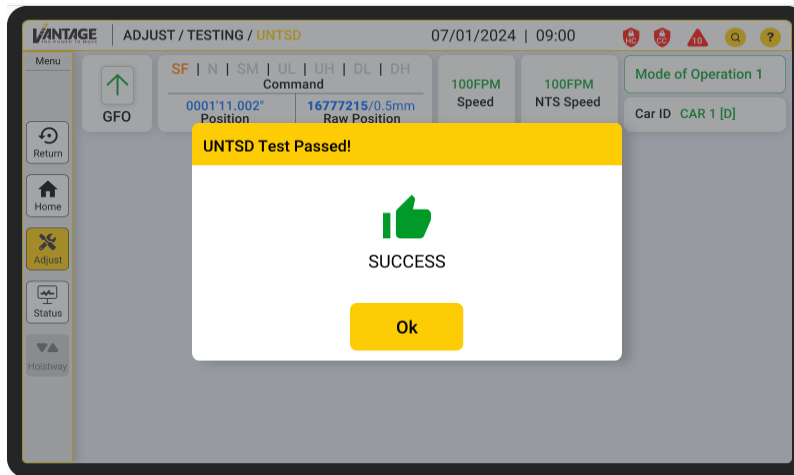

Figure 67: Compliance Testing Completion Message

8. Turn off DIP7 on the MR.

#### 4.1.5 TERMINAL SPEED REDUCING DEVICE (TSRD) – HYDRAULIC

In compliance with ASME A17.1 – Section 3.25.2, terminal speed-reducing devices shall be installed for the up direction where the car speed exceeds 0.25 m/s (50 ft/min), to ensure that the plunger does not strike its solid limit of travel at a speed in excess of 0.25 m/s (50 ft/min).

To test **TSRD**:

1. Place car at the bottom terminal
2. Capture the car by turning DIP5 ON (UP) in the MR. This takes the car out of the group. Capture Alarm displays when the car is captured.
3. Go to **Adjust > Testing**.

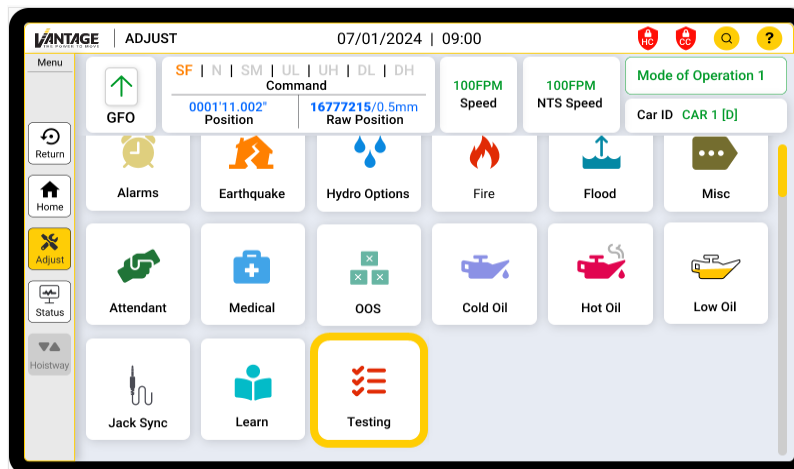

Figure 68: Compliance Testing Icon Screen

4. Select **TSRD** from the **Compliance Testing** list screen.

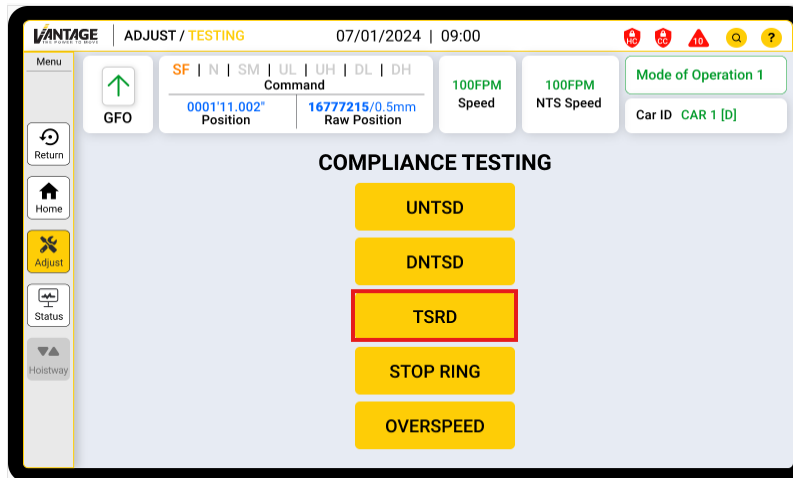

Figure 69: Compliance Testing Selection Screen - TSRD

5. If the car is not at the terminal landing, touch Call Car to Terminal.
6. Follow on-screen instructions to begin the test.
7. Once **TSRD** test passes, the success screen pops up.

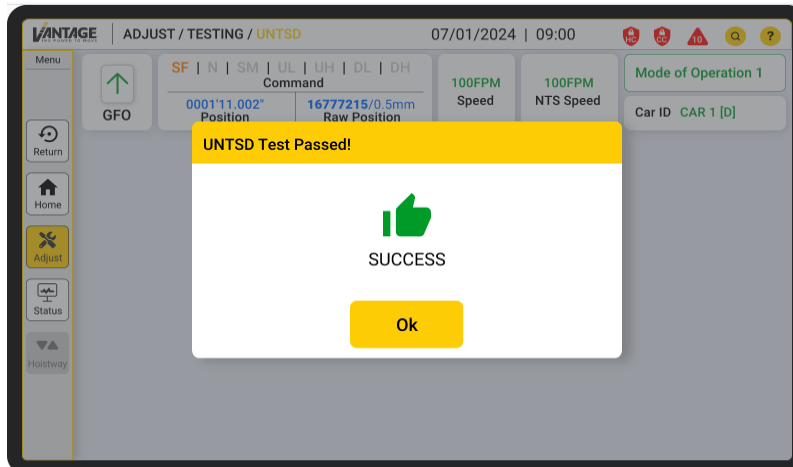

Figure 70: Compliance Testing Completion Message

8. Turn off DIP7 on the MR.

### 4.1.6 ETSD TEST

ETSD test must be done in both directions, follow the steps below to perform the tests.

1. Capture the car by turning DIP5 ON (UP) in the MR. This takes the car out of the group. Capture Alarm displays when the car is captured.
2. Go to **Adjust > Testing**.

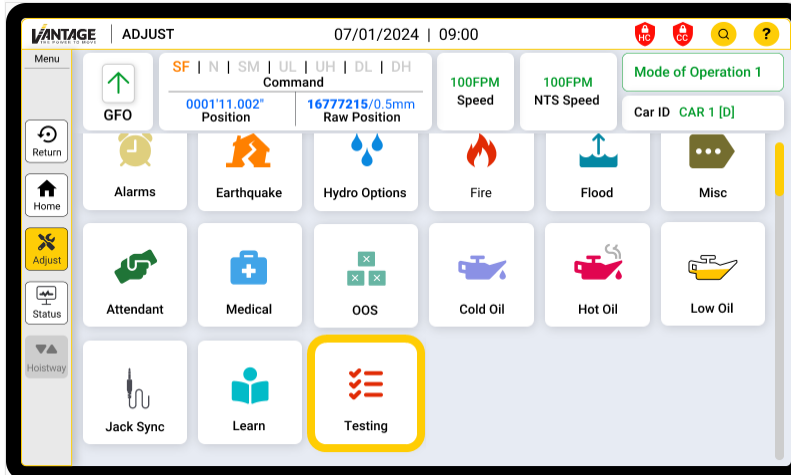

Figure 71: Compliance Testing Icon Screen

3. Select **UETSD** or **DETSD** from the **Compliance Testing** list screen.

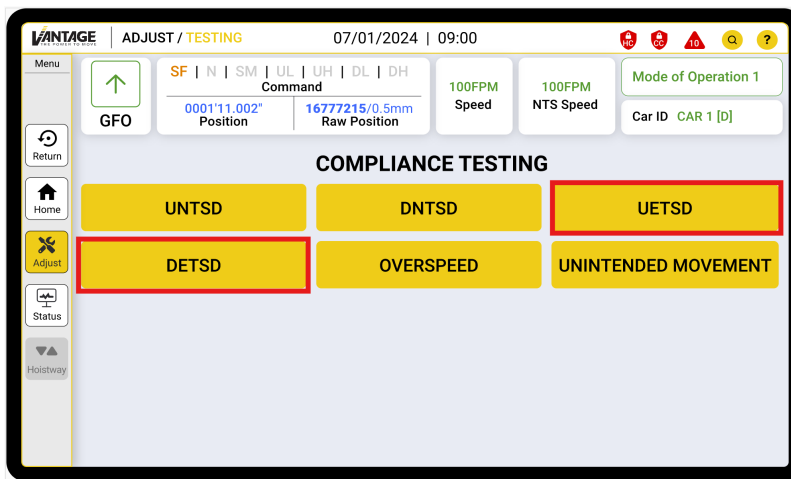

Figure 72: Compliance Testing Selection Screen - UETSD or DETSD

4. If the car is not at the terminal landing, touch Call Car to Terminal.
5. Follow on-screen instructions to begin the test.

6. Once test passes, the success screen pops up.

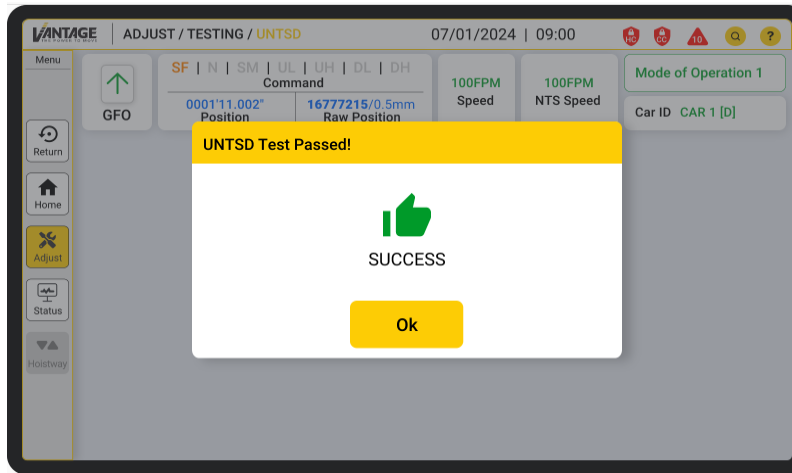

Figure 73: Compliance Testing Completion Message

7. Turn off DIP7 on the MR.

#### 4.1.7 UNINTENDED MOTION TEST

With an empty car, place the elevator at the bottom landing, level with the floor and the front doors open. Properly barricade the elevator opening and ensure that elevator personnel are outside the elevator at the bottom floor to ensure that no one enters the elevator during this test.

1. From the **Adjust > Test** screen, select **Unintended Movement Test**.

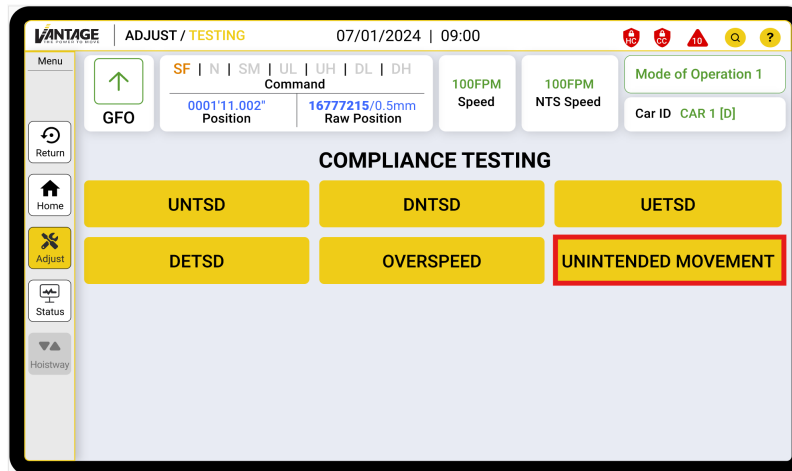

Figure 74: Compliance Testing Selection Screen - Unintended Movement

- Follow the onscreen instructions to select the proper opening and call the car to a floor if required.

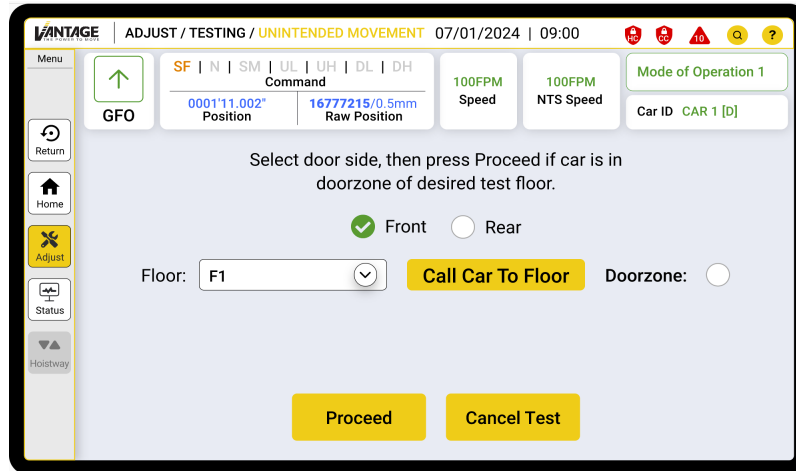

Figure 75: Unintended Movement Testing Adjustment Screen

- Follow the next screen instructions.

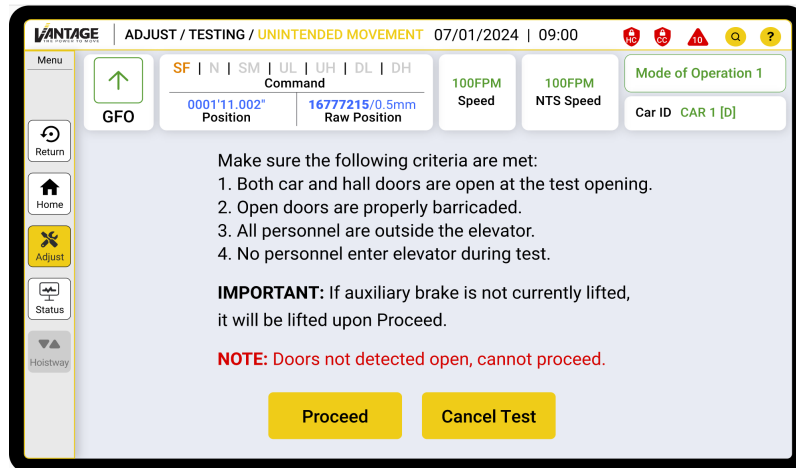

Figure 76: Unintended Movement Testing Screen

- The controller will be ready to release the main brake when the user manually presses the main brake (B1) contactor.

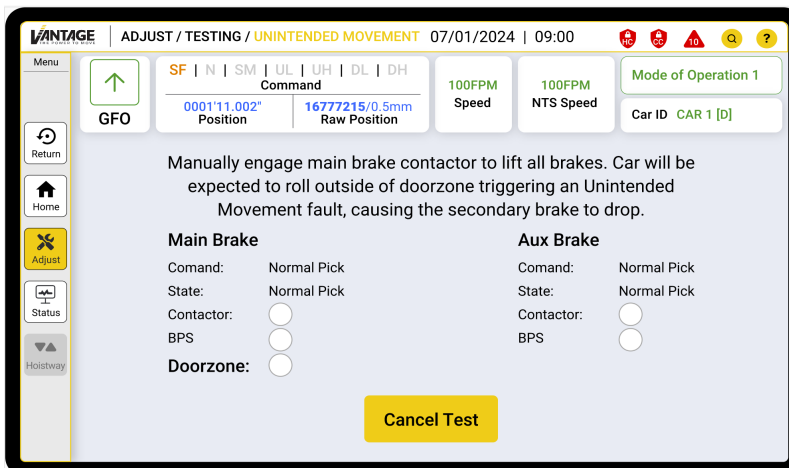

Figure 77: Unintended Movement Testing Status Screen

- When the car rolls outside of the door zone with the doors open, Unintended motion will trigger. The screen will record the starting distance when the emergency brake drops, and the difference between the two to estimate total distance moved.

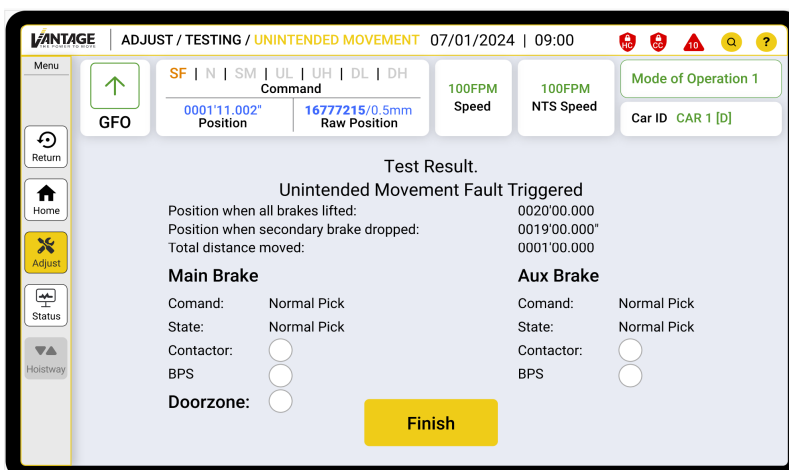

Figure 78: Unintended Movement Testing Results Screen

- With 125% load, place the elevator at the second landing, level with the floor and the front doors open on inspection. Properly barricade the elevator opening and ensure that elevator personnel are outside the elevator at the second floor to ensure that no one enters the elevator during this test. Repeat the steps above,
  - Push and hold the **Enable** and **UP** button. This will cause the elevator to roll down with the doors open.
  - Verify that the Rope Gripper or Emergency Brake activates and stops the car.

#### 4.1.8 OVERSPEED TEST

The **Overspeed** test allows the user to run the car at a speed greater than the contract speed to verify the overspeed safety devices.

1. From the **Adjust > Testing** menu, select the **Overspeed** test.

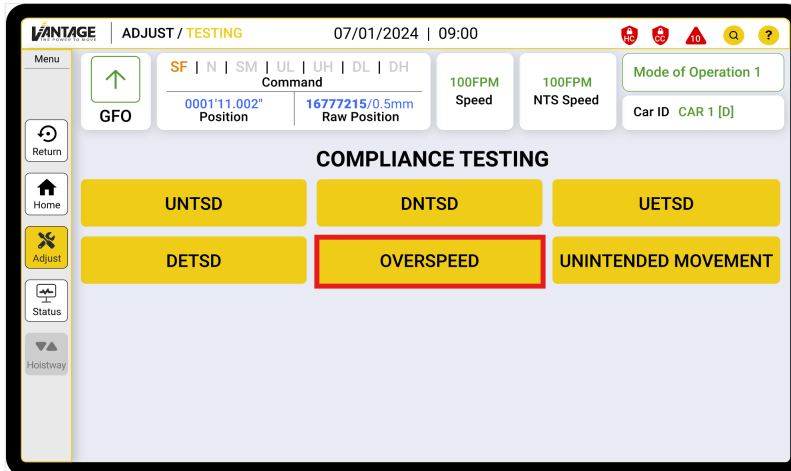

Figure 79: Compliance Testing Selection Screen - Overspeed

2. Follow the onscreen instructions to move the car to the terminal and setup the test.

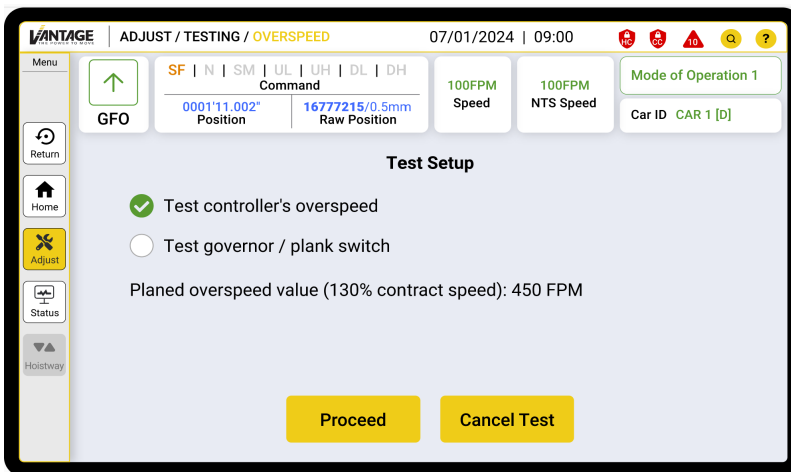

Figure 80: Overspeed Testing Setup Screen

3. Follow the onscreen instructions to run the test.

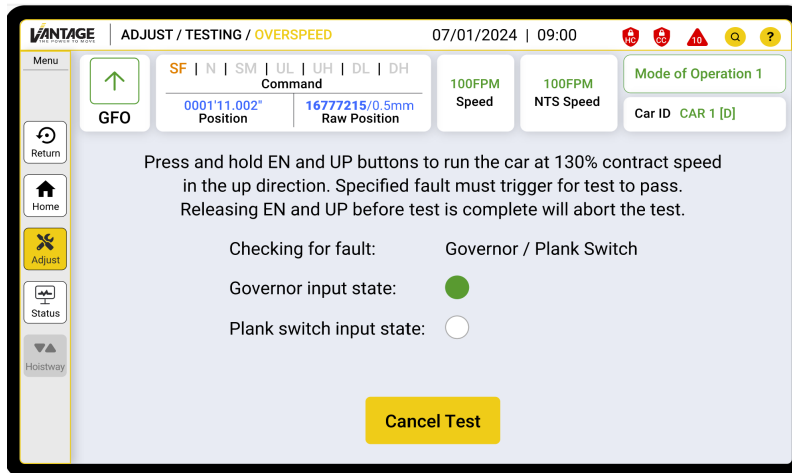

Figure 81: Overspeed Testing Status Screen

4. Test can be aborted at anytime by releasing the command buttons. Once the test is passed, the success screen will be shown.

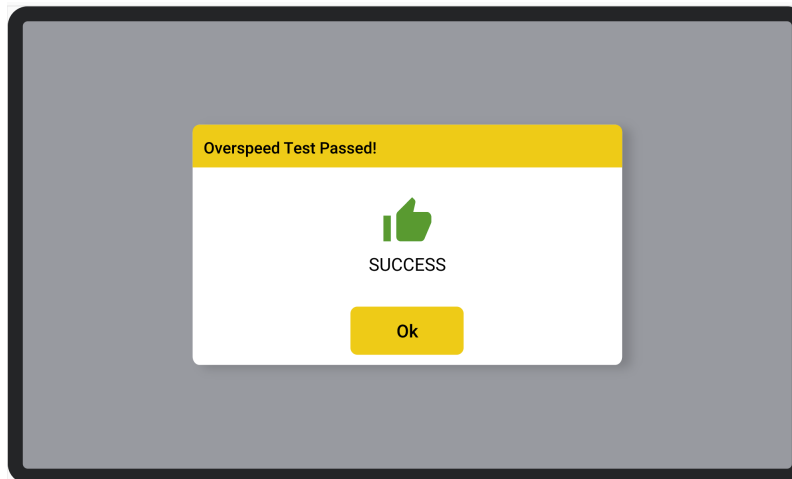

Figure 82: Compliance Testing Completion Message

# Section 5 Troubleshooting

## 5.1 FAULTS

Faults stop and prevent the car from running. Each board reports and clears their own fault. Faults clear after three seconds.

### 5.1.1 FAULT PROCESS

When a fault occurs:

1. The reporting board records the following information:
  - a. Time of fault
  - b. Position
  - c. Speed
  - d. Current Floor
  - e. Destination Floor
  - f. Door State Front
  - g. Door State Rear
  - h. Mode of Operation
2. The reporting board blinks its fault LED.
3. The reporting board transmits the fault information to the system.
4. When each board receives the fault information, each board blinks its fault LED.
5. The MR records the fault information into an entry of the FRAM for use with the fault log. The fault log supports up to 64 entries.
6. When the reporting board clears its fault, all boards stop blinking their fault LED. Faults can be viewed in two locations:
  - **Homescreen:** The **Faults** section of the **Home** screen displays the current active faults. Active faults are those currently present in the system. If a board suffers multiple faults at the same time, the highest priority fault becomes its active fault.

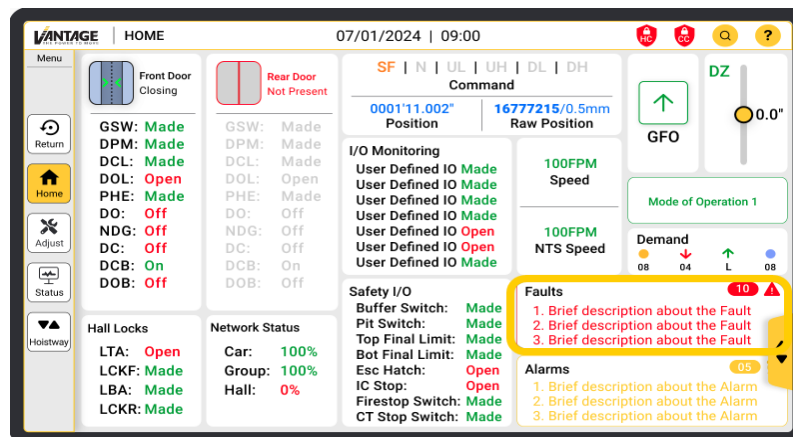

Figure 83: Home Screen Faults Selection

- **Fault Log screen.** This screen displays the recorded fault data from when the fault was captured. This screen can be accessed by tapping the faults section of the **Home** screen. This screen can also be accessed by navigating to **Home > Status > Faults** screen.

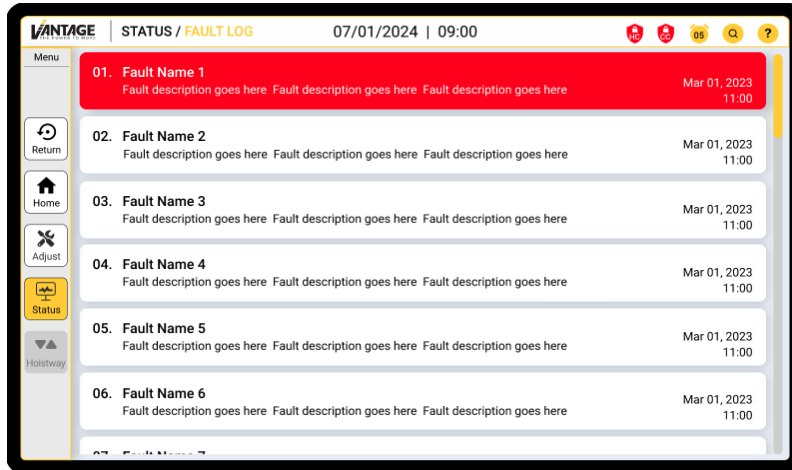

Figure 84: Fault Log Screen

## 5.1.2 FAULT RECORD

The fields listed below represent the columns referenced in the faults document.

- **Software Index:** The value identifier of the fault.
- **UI String:** String that identifies the fault on UI screens. Limited to 48 characters.
- **UI Description:** Description of how the fault is activated.
- **UI Troubleshooting:** Description of how to troubleshoot the fault.

## 5.2 ALARMS

Alarms alert technicians to check the controller. Alarms do not stop or prevent the car from running. Each board reports and clears their own alarm. Alarms clear after three seconds. The system supports up to 2000 alarms.

### 5.2.1 ALARMS OVERVIEW

When an alarm occurs:

- The reporting board records the following information:
  - Time of alarm
  - Position
  - Speed
  - Current Floor
  - Destination Floor
  - Door State Front
  - Door State Rear
  - Mode of Operation
  - Hall Board error
- The reporting board blinks its alarm LED.
- The reporting board transmits the alarm information to the system.

- When each board receives the alarm information, each board blinks its alarm LED.
- The alarm log supports up to 64 entries.
- When the reporting board clears its alarm, all boards stop blinking their alarm LEDs.
- Alarms can be viewed in two locations:
  - **Home screen.** The **Alarms** section of the **Home** screen displays the current active alarms. Active alarms are alarms that are currently active in the system. If a board has multiple alarms at the same time, the highest priority alarm is its active alarm.

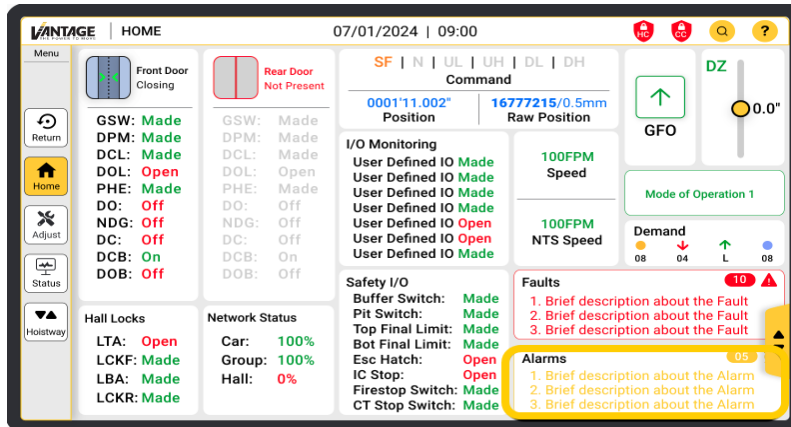

Figure 85: Home Screen Alarms Selection

**Alarm Log screen.** This screen displays the recorded alarm data from when the alarm was captured. This screen can be accessed by tapping the alarms section of the **Home** screen. This screen can also be accessed by navigating to the **Home > Status > Alarms** screen.

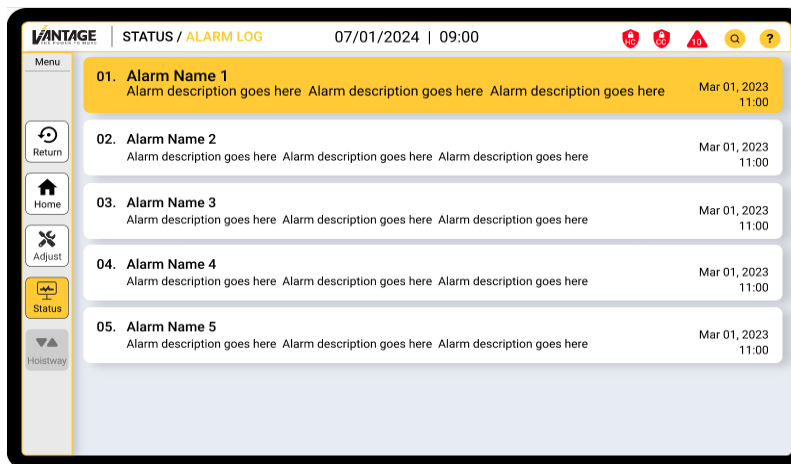

Figure 86: Alarm Log

## 5.2.2 ALARM FIELDS

---

The alarm fields shown are:

- **Software Index:** The unique value identifier of the alarm.
- **UI String:** String that identifies the alarm on UI pages. Limited to 48 characters. This field appears on the UI screens.
- **UI Description:** Description of how the alarm was activated. Limited to 400 characters.
- **UI Troubleshooting:** Description of how to troubleshoot the alarm. Limited to 576 characters.

# Section 6 Updating Software

Nexus uses a Bootloader to allow software to be installed to the system.

## 6.1 ENTERING AND EXITING BOOTLOADER MODE

To enter the bootloader mode for all nodes, change the MR, CT or COP board's DIP switch 1 from the OFF to the ON position as shown in **Figure 3**.

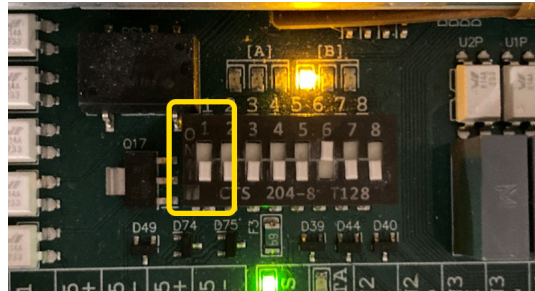

Figure 87: Flip DIP switch 1 from the OFF to the ON position

After setting DIP switch 1 to the ON position, hit the RESET button on the board that will initiate the bootloader sequence. After the board is restarted, the entire system will enter bootloader mode. Once in bootloader mode, the screens for the MR, CT and COP display the bootloader menu options. Additionally, all other nodes should rapidly blink to their green status LED.

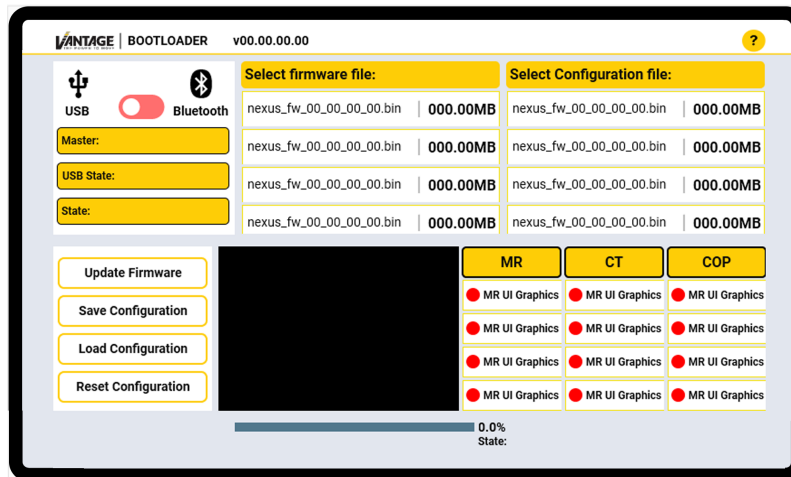

Figure 88: Bootloader Screen (Example)

To exit bootloader mode, simply set the MR, CT and COP DIP switch 1 from the ON position to the OFF position. This will make the nodes perform a system reset and start the application normally.

If a node cannot find a valid application installed in its flash storage, the node will simply stay in bootloader mode. This can be easily identified by seeing the green LED of that node rapidly flashing while the other nodes flash their LEDs normally. If this is the case, please enter bootloader mode, and flash the application again.

## 6.2 PREPARING USB WITH NEXUS FIRMWARE

Connect the USB 2.0 stick (formatted to FAT32) With the Binary file (nexus\_fw\_X\_X\_XX\_X\_XXXXX.bin) to the MR or CT USB port as shown in the following figure.

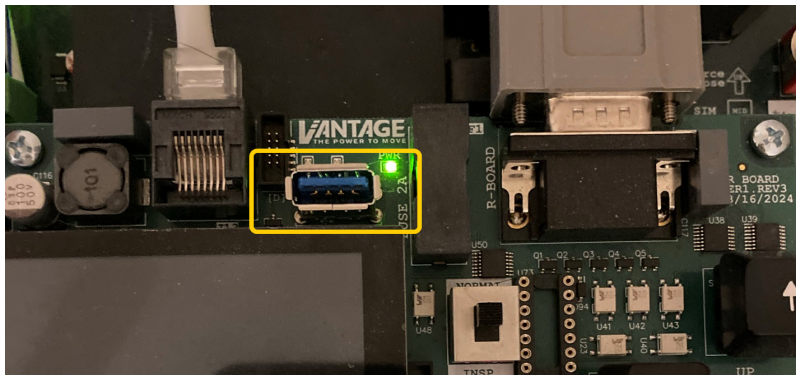

Figure 89: Insert USB on the MR or CT board USB slot

## 6.3 FLASHING NEW APPLICATIONS TO NODES

On the MR screen, select the firmware file (1), and the nodes to be flashed (2). Once the selections have been confirmed, please press the "Update firmware" button (3). See the following figure to identify the different UI components on the bootloader menu.

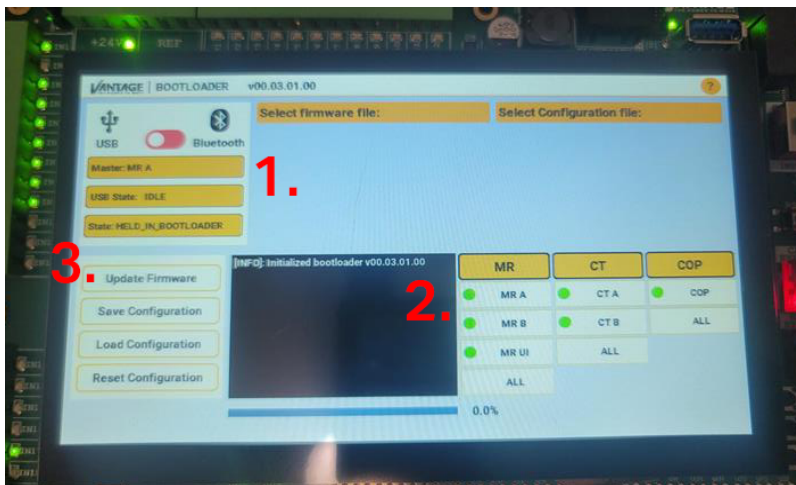

Figure 90: Bootloader Screen

Observe the progress and status of the flashing process at the progress bar and the bootloader message window.







**DO NOT DISCONNECT POWER TO THE NEXUS SYSTEM WHILE FLASHING NODES.**

### 6.3 BOOTLOADER LED SEQUENCE STATUS

The three onboard LEDs for MR, CT and COP display the status of the bootloader. **Table 5** shows the LED color and sequence that represents the status of the bootloader.

*Table 5: Bootloader LED Status*

LED Flash Sequence	Status
 0.1 Seconds	Heartbeat, bootloader online
 0.001 – 0.1 Seconds	Master-sending, Slave-receiving
 0.25 Seconds, 10 times	Bootloader error
 Continuous	Hard fault

# Glossary

- **AHJ:** Authority Having Jurisdiction
- **ASME:** American Society of Mechanical Engineers
- **BFL:** Bottom Final Limit
- **BUF:** Buffer Switch
- **CC:** Car Call
- **COP:** Car Operating Panel
- **CT:** Car Top
- **DC:** Door Close
- **DCB:** Door Close Button
- **DCL:** Door Close Limit
- **DH:** Down High
- **DL:** Down Leveling/Low or Down Lantern/Lamp
- **DNTS:** Down Normal Terminal Slowdown
- **DO:** Door Open
- **DOB:** Door Open Button
- **DOL:** Door Open Limit
- **DPM:** Door Position Monitoring
- **DZ:** Door Zone
- **FPM:** Feet Per Minute
- **GSW:** Gateswitch (Car Gate)
- **HC:** Hall Call
- **HB:** Hall Board
- **INSP:** INSPECTION switch position on Machine Room board
- **LBA:** Lock Bottom Access
- **LCKF:** Locks Front
- **LCKR:** Locks Rear
- **LTA:** Lock Top Access
- **MCU:** Micro Controller Unit
- **MR:** Machine Room
- **N:** Neutral Relay
- **NDG:** Nudge
- **NEMA:** National Electrical Manufacturers Association
- **NTSD:** Normal Terminal Stopping Device (the camera sensor feedback)
- **PHE:** Photoeye
- **PI:** Position Indicator
- **PIT:** Pit Switch
- **PLD:** Programmable Logic Device
- **TSRD:** Terminal Speed Reducing Device
- **SF:** Safety Relay
- **UI:** User Interface
- **UL:** Up Leveling/Low or Up Lantern/Lamp
- **UNTS:** Up Normal Terminal Slowdown
- **UH:** Up High
- **VAC:** Volts Alternating Current
- **VDC:** Volts Direct Current