

PAD POSITION REFERENCE;
CENTERLINE OF ROPE WILL
VARY WITH ROPE SIZE

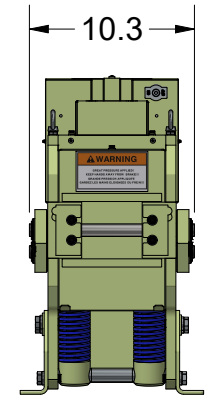
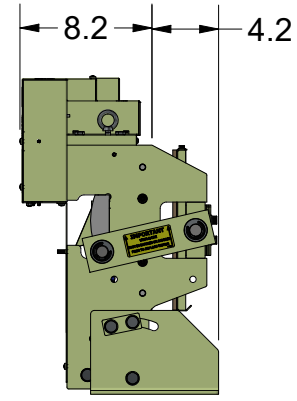
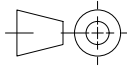

WEIGHT: 120 lbmass

		D	REMOVED MD1 / MD2 / P-237 & UPDATED SOFTWARE / LABELING FOR 4 WIRE SYSTEM, UPDATED NAMEPLATE, PUR #1773	DRO 05/23/23	HOLLISTER-WHITNEY ELEVATOR CO. LLC			
E					REVISED CONDUIT KNOCKOUT, PUR #1939	DRO 04/14/25	TITLE 622L - LINEAR ROPE GRIPPER ASSEMBLY	
THIS DRAWING IS SUPPLIED AS A REPRESENTATION OF THE EQUIPMENT HOLLISTER-WHITNEY ELEVATOR CO. LLC ("MANUFACTURER") HAS AGREED TO SUPPLY. SLIGHT ADJUSTMENTS MAY OCCUR DURING MANUFACTURING AND INSTALLATION. ANY MODIFICATIONS NOT APPROVED IN WRITING BY MANUFACTURER MAY AFFECT OPERATION, VOIDS ANY WARRANTY AND RELEASES MANUFACTURER OF ALL LIABILITY. THIS DOCUMENT CONTAINS CONFIDENTIAL AND PROPRIETARY INFORMATION THAT CANNOT BE REPRODUCED OR DIVULGED, IN WHOLE OR IN PART, WITHOUT WRITTEN AUTHORIZATION FROM THE MANUFACTURER.			THIRD ANGLE PROJECTION 		DRAWN BY DRO	SCALE 1:12	MATERIAL N/A	REFERENCE TOL. ALL DIMENSIONS REFERENCE UNLESS OTHERWISE SPECIFIED
					SHEET SIZE A	DATE 6/14/2019	622L SHEET 1 OF 1	