



# REGIONAL SERVICE CENTER PARTS CATALOG

SPARE PARTS | TECHNICAL SUPPORT | TRAINING | SALES | PROJECT COORDINATION

# VANTAGE

THE POWER TO MOVE



PAGE  
04



PAGE  
46



PAGE  
68



PAGE  
70



SCAN TO DOWNLOAD APP

# INDUSTRY LEADING FIXTURES & SOLUTIONS

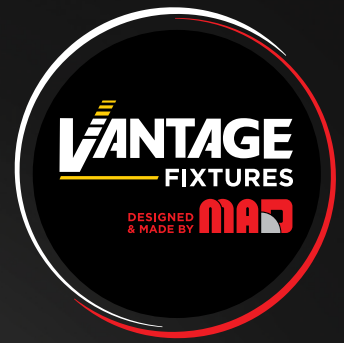

Vantage is proud to be the exclusive source for MAD Fixtures to the Independent Market in North America. Now offering the convenience and value of a combined controller/fixture solution across all Vantage controller product lines. Contact [sales@vantageelevation.com](mailto:sales@vantageelevation.com) for more information.



# WELCOME TO FASTER ELEVATOR PARTS, SERVICE, AND SUPPORT

This catalog contains the parts you need to keep your passenger and freight elevators running optimally. It contains parts from four Vantage companies: GAL Manufacturing, Hollister-Whitney, Elevator Controls and Courion.

The Vantage family of brands has served the elevator community with dependable, non-proprietary elevator transportation modernization solutions and outstanding customer care. The promise we make to our customers is to remain true to our heritage of quality and excellence, while delivering the innovative solutions that meet the needs of tomorrow. Together, we leverage our collective expertise and experience to deliver the power to move.



## GAL

Non-proprietary elevator door equipment, controls, and signal fixtures. Renowned for solid customer service and crafting innovative products.

## HOLLISTER-WHITNEY

Extensive line of elevator hoist machines for gearless and geared applications, elevator platforms, slings, safeties, guides, governors, buffers, equipment guarding, and patented Rope Gripper systems.

## ELEVATOR CONTROLS

Complex vertical transportation control systems, specifically non-proprietary, microprocessor-based systems that are uniquely simple for customers to install, adjust, and maintain

## COURION

Durable and reliable solutions for freight elevator doors, car gates, car enclosures, and all related systems and components. Freight Tech, a subsidiary of Courion, specializes in installation, repair, and maintenance.

## VANTAGE REGIONAL SERVICE CENTERS

Close to you for faster parts, service, and support

Vantage Regional Service Centers provide the whole suite of Vantage products. In addition to a warehouse stocked with a wide range of spare parts (same day or expedited pick up), Vantage Regional Service Centers provide local resources for sales, technical support, training, and project coordination.

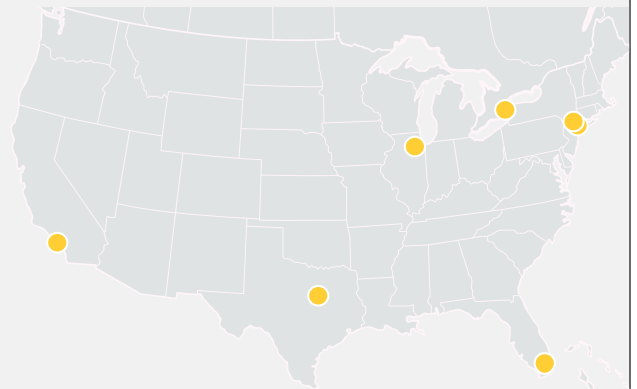

### NEW YORK - BRONX

50 E. 153rd St.  
Bronx, NY 10451  
917.336.4597

### NEW YORK - QUEENS

19-19 37th St.  
Astoria, NY 11105  
917.336.4597

### LOS ANGELES

9704 Jordan Circle,  
Santa Fe Springs, CA 90670  
877.300.5816

### CHICAGO

1930 East Devon Ave.  
Elk Grove Village, IL 60007  
877.300.5830

### MIAMI

15825 NW 15th Ave.  
Miami Gardens, FL 33169  
877.241.9354

### TORONTO

6500 Gottardo Ct.  
Mississauga, ON L5T 2A2  
888.425.2262

### DALLAS

3247 W. Story Road  
Irving, Texas 75038  
469.706.9316



# GAL PARTS

# DOOR EQUIPMENT

## DOOR OPERATORS MOVFR/MODL

PART ID	PART DESCRIPTION
OP1-0089L	OPERATOR, SS-2S, MODL, LH (NO DRIVE ARM)
OP1-0089R	OPERATOR, SS-2S, MODL, RH (NO DRIVE ARM)
OP2-0086N	OPERATOR, MODL, CP (NO DRIVE ARM)
OP106-0004L	OPER, SS-2S, 36 D.O. MOVFRW II W/ DRIVE ARM, LH
OP106-0004R	OPER, SS-2S, 36 D.O. MOVFRW II W/ DRIVE ARM, RH
OP106-0005L	OPER, SS-2S, 42 D.O. MOVFRW II W/ DRIVE ARM, RH
OP106-0005R	OPER, SS-2S, 42 D.O. MOVFRW II W/ DRIVE ARM, LH
OP108-0003N	OPER, CP 40-49 D.O. MOVFRW II W/ DRIVE ARM
OP115-0003L	OPER, SS-2S MOVFR II (NO DRIVE ARM)
OP115-0003R	OPER, SS-2S MOVFR II (NO DRIVE ARM)
OP115-0004N	OPER, CP MOVFR II (NO DRIVE ARM)

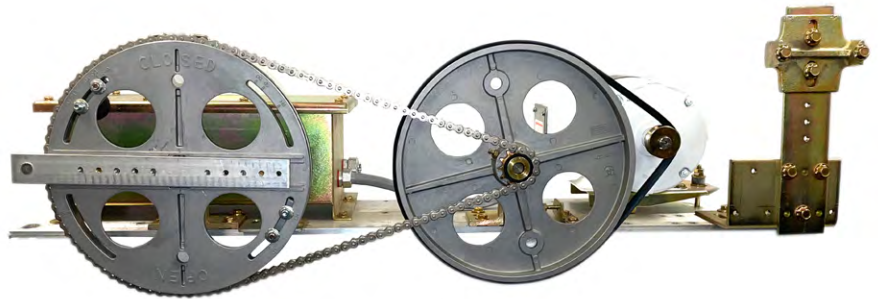

OP106-0004L

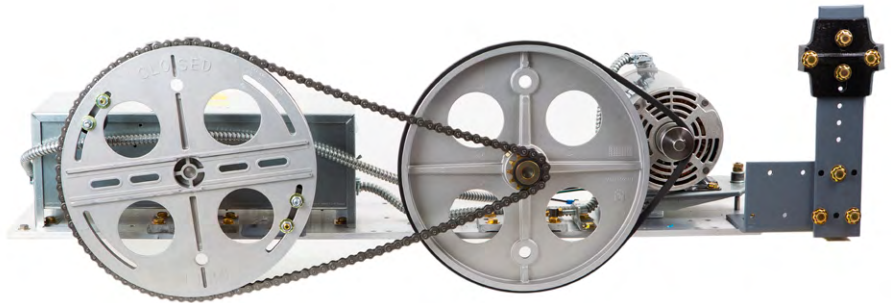

OP115-0003L

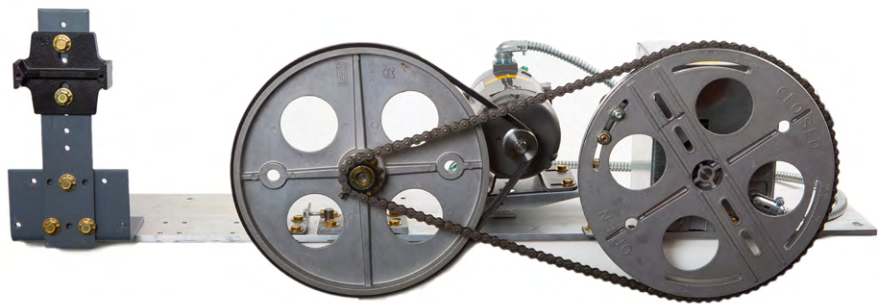

OP1-0089R

# HOW TO CHOOSE AN OPERATOR FROM TABLES

- 1) Choose Equipment Type:
  - Conventional
  - Vandal Resistant
  - Dust/Explosion Resistant
  - Water Resistant
- 2) Choose Operator Models. (Example: MOVFRII, MODL, MOHL...ETC.)
- 3) Door Style :
  - Single Speed
  - Two Speed
  - Three Speed
  - Center Parting
  - Two Speed Center Parting
  - Three Speed Center Parting
- 4) Voltage Supply :
  - Standard - 200 - 230 V AC for MOVFR II Operators
  - 200 - 230 V DC for DC Operators
  - 200 - 230 V AC/DC for CT Operators
  - Contact G.A.L. for 100 - 115 V AC/DC

**5) Header Height**

**How to CHOOSE Header Height**

**Method 1: Measure the existing Operator Header**  
 When choosing a header size from tables, use the exact size or the next largest size. EXAMPLE: 14" existing header for single speed, use 15" header from tables.

**Method 2: Formula: 'C' + 1" - 'A' = 'H'**  
 Measure O.A. cab height 'C', the door opening O.A. height 'A'. Use the difference between 'C' + 1" and 'A' to determine header height from tables. Header height must match with or be greater than this difference 'H'.

**6) Door Opening Size, Width & Height**

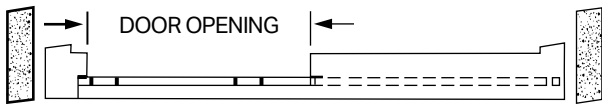

**7) Specify Hand**

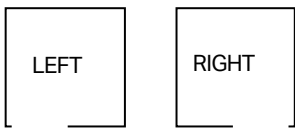

**Door hand determined by what side the strike jamb is on from corridor or hall looking into elevator**



**NOTE:**

**"L" Type Operators** are supplied with aluminum drive arm assemblies. **Shoe Type Operators** are supplied with crank arm w/ roller bearing & drive shoe. **Gate Switch**, mandatory & included with all operators, is charged separately.

**Door Link & Bracket** is needed if **NO** G.A.L. clutch is being used.

If **Center Parting Operator** is ordered and not being used with a G.A.L. hanger, **(2)** drive arm support brackets (**OP25-0001N** or **OP25-0002N**) are required for mounting drive arm to existing header.

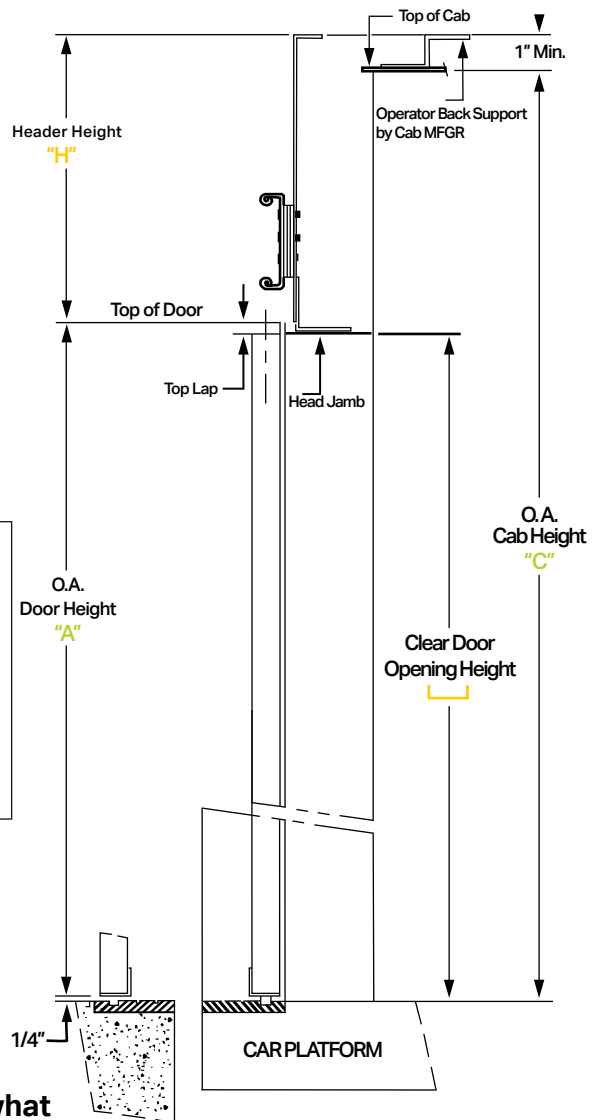

# OPERATOR ISOMETRIC DRAWING MOVFR II OPERATOR

SINGLE SPEED 22"-48" D.O./  
TWO SPEED 30"-72" D.O.

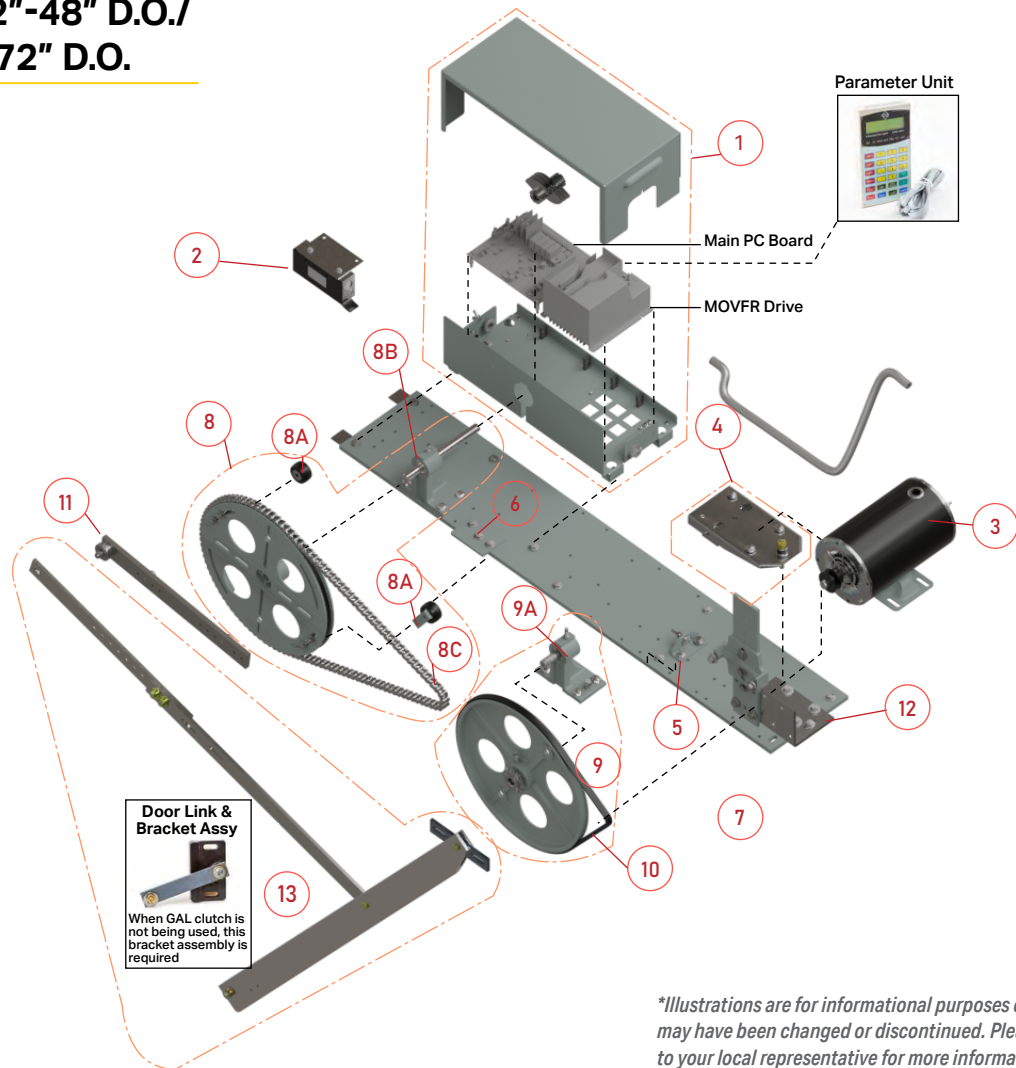

*\*Illustrations are for informational purposes only. Part #'s may have been changed or discontinued. Please reach out to your local representative for more information.*

ITEM NO	PART DESCRIPTION
1	MOVFR II LIMIT CONTROL ASSEMBLY
2	GATE SWITCH ASSEMBLY
3	1/2 HP 230 VAC MOTOR
4	MOTOR BASE ASSEMBLY
5	BEARING BLOCK ADJUSTABLE ANGLE
6	STOP ROLLER PLATE
7	MOTOR PULLEY
8	DRIVE PULLEY & BEARING ASSEMBLIES
8A	STOP ROLLER ASSEMBLY

ITEM NO	PART DESCRIPTION
8B	DRIVE BEARING BLOCK ASSEMBLY
8C	DRIVE PULLEY CHAIN
9	INTERMEDIATE PULLEY & BEARING BLOCK ASSEMBLIES
9A	INTERMEDIATE BEARING BLOCK ASSEMBLY
10	2440 "V" BELT
11	CRANK ARM ASSEMBLY
12	DRIVE ARM SUPPORT ASSEMBLY
13	DRIVE ARM ASSEMBLY

# MOVFR II WIRING DIAGRAMS

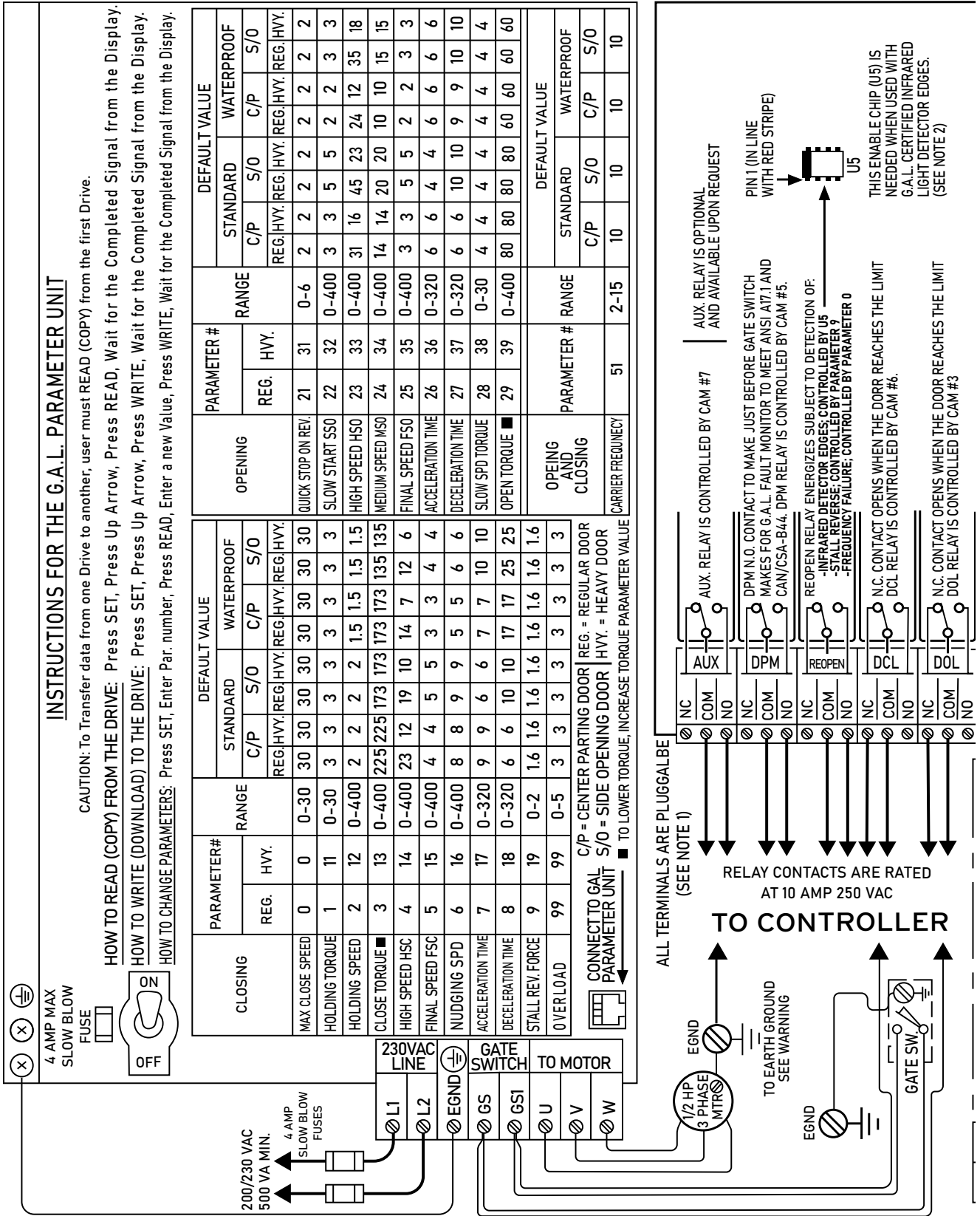

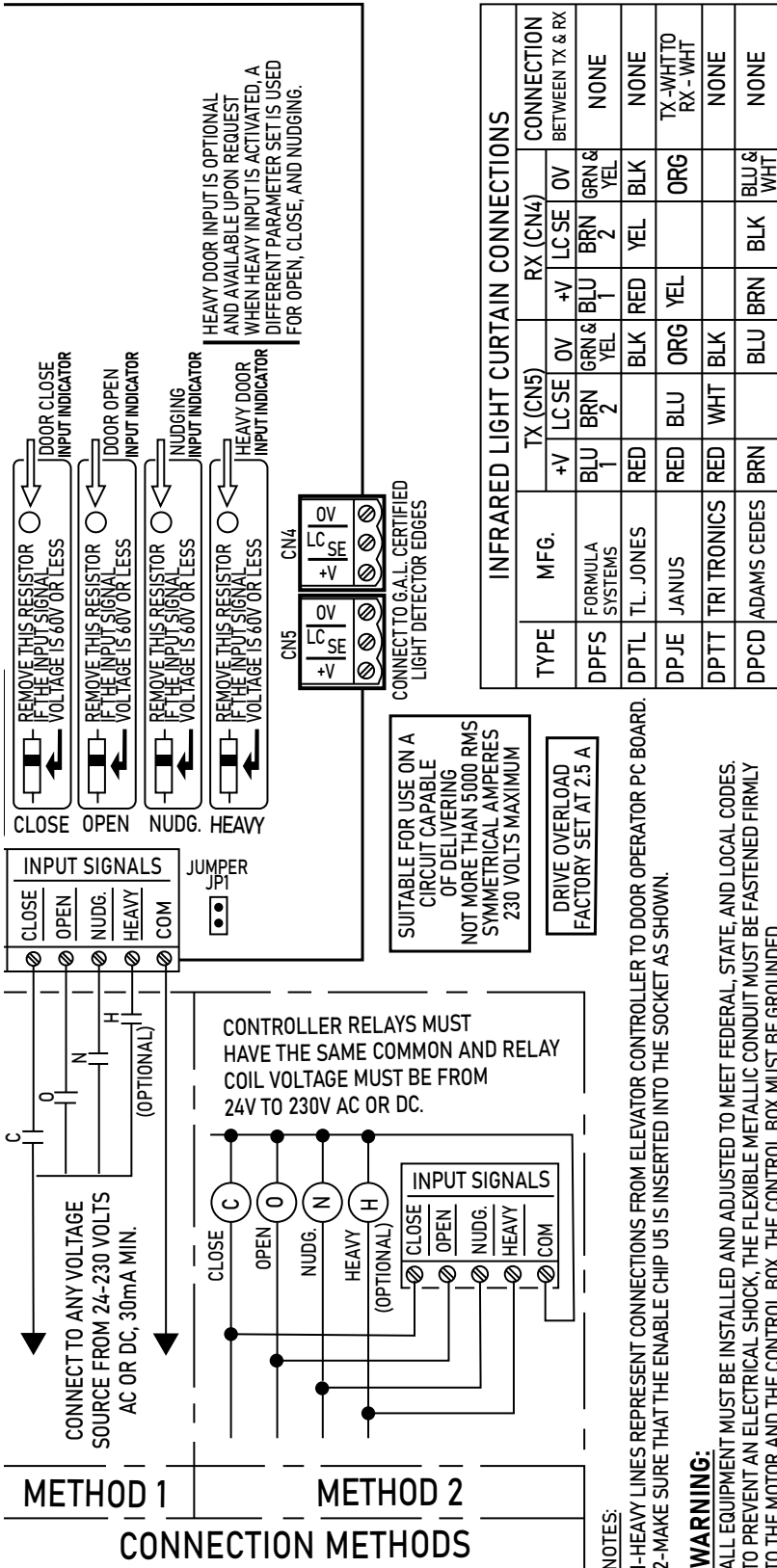

DATE 1 - 24 - 05  
DOC. No. 8032

**MOVFR DOOR OPERATOR WITH MOVFR II  
LIMIT CONTROL CONNECTION DIAGRAM**

**G.A.L. MANUFACTURING CORP.**  
50 E. 153rd STREET  
TEL. 718 292 9000  
BRONX, N.Y. 10451  
FAX 718 292 2034



# OPERATOR ISOMETRIC DRAWING MODL OPERATOR

SINGLE SPEED 22"-48" D.O./  
TWO SPEED 30"-72" D.O.

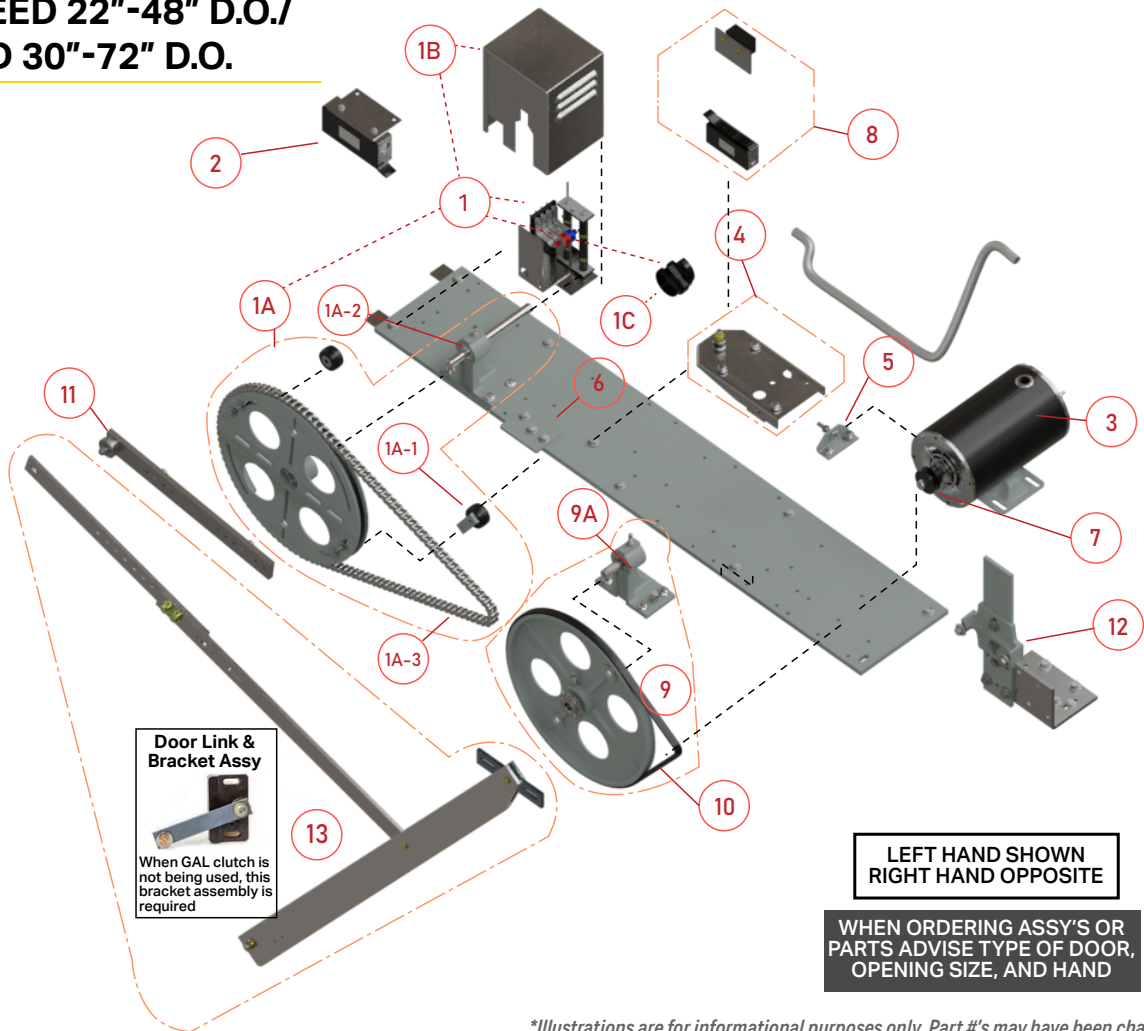

*\*Illustrations are for informational purposes only. Part #'s may have been changed or discontinued. Please reach out to your local representative for more information.*

ITEM NO	PART DESCRIPTION
1	MOD LIMIT CONTROL ASSEMBLY
1A	MOD DRIVE PULLEY & BEARING ASSEMBLY
1A-1	STOP ROLLER ASSEMBLY
1A-2	DRIVE BEARING BLOCK ASSEMBLY
1A-3	DRIVE PULLEY CHAIN
1B	LIMIT CONTROL BOX COVER
1C	LIMIT CONTROL CAM SET
2	GATE SWITCH ASSEMBLY
3	1/6 HP 230 VDC PM MOTOR
4	MOTOR BASE ASSEMBLY
5	BEARING BLOCK ADJUSTABLE ANGLE

ITEM NO	PART DESCRIPTION
6	STOP ROLLER PLATE
7	MOTOR PULLEY
8	MICROSWITCH KIT
9	INTERMEDIATE PULLEY & BEARING BLOCK ASSEMBLIES
9A	INTERMEDIATE BEARING BLOCK ASSEMBLY
10	2440 "V" BELT
11	CRANK ARM ASSEMBLY
12	DRIVE ARM SUPPORT ASSEMBLY
13	DRIVE ARM ASSEMBLY

# DOOR OPERATOR PARTS

PART ID	PART DESCRIPTION
MOVFE-0002N	MOVFE DRIVE/PCB ASSY 230VAC
MOVFE-0003N	MOVFE DRIVE/PCB ASSY 115VAC
MOVFE-0008N	MOVFE, PARAMETER UNIT
DPPC-0001N	CHIP PROTECTION ENABLING
DRV-0003N	PARAMETER UNIT, FR-PU04-7 HAND HELD W/CBL
DRV-0009N	PARAMETER UNIT, MOVFR II HAND HELD 7FT
HH5-0029N	OILER, TYPE "C" HANGER 3-1/4" ROLLER
HWBL-0001N	BELT, 2440 TRUFLEX "V"
HWBR-0001N	BEARING, 7/8 OD X 3/8 ID NO SHOULDER
HWBR-0008N	BEARING KIT, 7/8 SHOULDER
HWBR-0009N	BEARING KIT, 7/8 WITH RETAINER
HWBR-0013N	BEARING, 3.157" LG PUMP
HWBR-0014N	BEARING, 6.388" LG PUMP
HWBS-0001N	BUSHING, NYLINER TYPE 7, .250 ID X .140
HWBS-0002N	BUSHING, NYLINER 5/8 ID TYPE 4
HWNR-0001N	SLEEVE, 3/8" OD X 5/16" ID X 17.75 NYLON
HWRV-0014N	PIN, CLEVIS, .25 X .688, CS, COTTERLES
HWSC-0072N	SCREW, 1/4-20 X 3/8" HEX LOWER HDSTEEL
HWSC-0186N	SCREW, 3/8-16 X 3/4" HEX HD STEEL PLATED
HWWS-0092N	WASHER, .656 ID X 1.25 OD FLAT STEEL
IC-0068N	IC, OPTOISOLATOR DARYLINGTON TRANSISTOR
IC-0072N	IC, TRIAC 1.2A 120VAC 8 PIN DIP
IC-0129N	IC, TRIAC 1.2A 120VAC 8 PIN DIP
MOVFR-0002N	INPUT PC, MOVFR & MOVFR II BOARDS
MOVFR-0070N	BOARD, MOVFR II & MOVFRW II MAIN PC
MOVFR-0072N	DRIVE, MOVFR II OPERATOR FREQUENCY 230VA
MOVFR-0074N	RELAY/CAM SET, MOVFR II AUX OUTPUT SIGNAL
MOVFR-0075AN	BOARD, MOVFR II & MOVFRW II MAIN PC
MOVFR-0099N	DRIVE, 115VAC MOVFR II OPERATOR FREQUENCY
MOVFR-0502AN	BOARD, MOVFR II CAN BUS INTERFACE SMT
MTR-0008N	MOTOR, 1/6 HP 230VDC PM
MTR-0010N	MOTOR, 1/2 HP 230VDC PM BALDOR
MTR-0011N	MOTOR, 1/6 HP 115 VDC PM
MTR-0021N	MOTOR, 1/2 HP 230VAC
MTR-0023N	MOTOR, 1/2 HP 208-230/460V-WITH CABLE
OP1-0005L	OPERATOR, SS-2S 35"-39" D.O. MODL
OP1-0005R	OPERATOR, SS-2S 35"-39" D.O. MODL
OP1-0089L	OPERATOR, SS-2S MODL KIT
OP1-0089R	OPERATOR, SS-2S MODL KIT
OP2-0086N	OPERATOR, CP MODL KIT
OP10-0004L	SWITCH ASSEMBLY, MOD LIMIT
OP10-0004R	SWITCH ASSEMBLY, MOD LIMIT
OP10-0007N	CAMS ASSEMBLY, MOD LIMIT BRIDGING
OP10-0008N	CAM, MOD SMALL BRIDGING ASSY
OP10-0009N	CAM, MOD LARGE BRIDGING ASSY
OP10-0010N	CONTACT, OPERATOR UPPER BRIDGING
OP10-0023N	RESISTOR ASSEMBLY, MOD 230V
OP10-0024N	RESISTOR ASSEMBLY, MOD 115V
OP10-0072N	STOP ROLLER ASSEMBLY, OPERATOR PULLEY
OP10-0080N	PULLEY, MOD OPERATOR DRIVE
OP16-0017L	SWITCH ASSEMBLY, MODCT LIMIT
OP16-0017R	SWITCH ASSEMBLY, MODCT LIMIT
OP17-0013L	SWITCH ASSEMBLY, MOMCT/MOHCT
OP17-0013R	SWITCH ASSEMBLY, MOMCT/MOHCT
OP20-0003N	PULLEY, MOD INTERMEDIATE /15 TOOTH



MOVFE-0002N



MOVFE-0008N



DRV-0009N

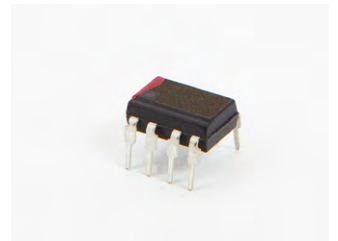

DPPC-0001N



MOVFR-0070N



MOVFR-0072N



MTR-0008N



MTR-0021N



MTR-0023N

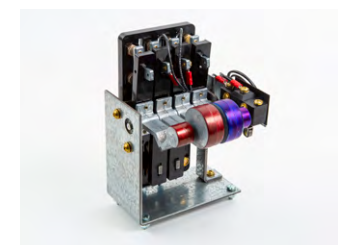

OP16-0017L



HWBL-0001N



HWBR-0008N

# DOOR ARM ASSEMBLIES & PARTS

## MOVFR SS - DRIVE ARM DRAWINGS

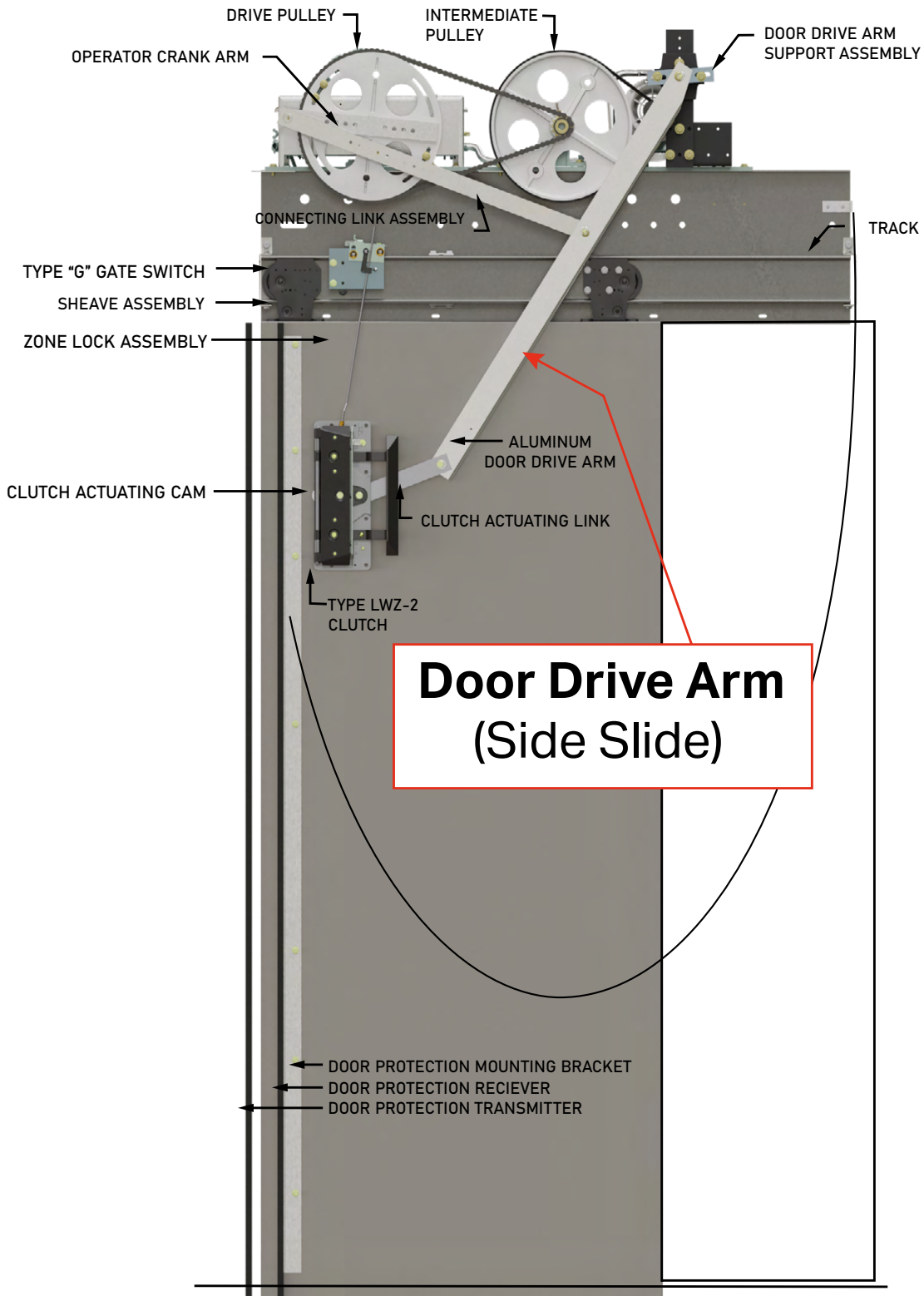

PART ID	PART DESCRIPTION
OP22-0002L	ARM ASSEMBLY, SS 25"-29" D.O.
OP22-0002R	ARM ASSEMBLY, SS 25"-29" D.O.
OP22-0003L	ARM ASSEMBLY, SS-2S 30"-34" D.O.
OP22-0003R	ARM ASSEMBLY, SS-2S 30"-34" D.O.
OP22-0004L	ARM ASSEMBLY, SS-2S 35"-39" D.O.
OP22-0004R	ARM ASSEMBLY, SS-2S 35"-39" D.O.
OP22-0005L	ARM ASSEMBLY, SS-2S 40"-44" D.O.
OP22-0005R	ARM ASSEMBLY, SS-2S 40"-44" D.O.
OP22-0006L	ARM ASSEMBLY, SS-2S 45"-48" D.O.
OP22-0006R	ARM ASSEMBLY, SS-2S 45"-48" D.O.
OP22-0007N	ARM ASSEMBLY, CP 30"-33" D.O.
OP22-0008N	ARM ASSEMBLY, CP 34"-39" D.O.
OP22-0009N	ARM ASSEMBLY, CP 40"-49" D.O.
OP22-0010N	ARM ASSEMBLY, CP 50"-54" D.O.
OP22-0011N	ARM ASSEMBLY, CP 55"-59" D.O.
OP22-0043N	ARM ASSEMBLY, C-HGR 2SCP 32 DO
OP22-0065N	BRACKET, 6" DOOR LINK &
OP22-0066N	BRACKET, 8" DOOR LINK &
OP22-0067N	BRACKET, 10" DOOR LINK &
OP22-0068N	BRACKET, 12" DOOR LINK &
OP22-0167N	ARM ASSEMBLY, CP 40"-44" D.O.
OP22-0177N	LINK, TYPE "III" OPERATOR CONNECTING ASSY
OP22-0178N	LINK, OPERATOR 17 1/4"LG. CONNECTING
OP22-0180N	LINK, TYPE "II" SLOTTED CONNECTING
OP22-0280N	LINK, 6" CL TO CL 3S INTERMEDIATE DOOR
OP22-0294N	LINK & BRACKET, SLOW DOOR
OP22-0531N	ARM, 75"LG UNIVERSAL ALUMINUM DRIVE
OP22-0740N	SIDE SLIDE OPERATOR CRANK ARM
OP22-0742N	CENTER PARTING OPERATOR CRANK ARMS
OP22-0743N	CENTER PARTING OPERATOR CRANK ARMS
OP24-0001N	SUPPORT ASSEMBLY, DRIVE ARM 12 HEIGHT
OP24-0008N	PLATE, 14 5/8"LG ARM SUPPORT
OP24-0026N	MICROSWITCH KIT, LRD-1/LRD-2
OP24-0032N	ANGLE, OPERATOR DRIVE ARM SUPPORT
OP25-0001N	BRACKET, CP ARM SUPPORT
OP25-0003N	HARDWARE, CP-2CP PIVOT
OP34-0079N	PLATE ASSY, CP-2SCP 5" CL ARM SUPPORT
OP71-0003L	SWITCH ASSEMBLY, MOX/MOW LIMIT
OP71-0003R	SWITCH ASSEMBLY, MOX/MOW LIMIT



OP22-0003L



OP22-0065N

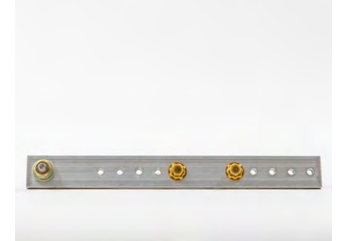

OP22-0740N



OP22-0531N



OP22-0742N



OP24-0001N



OP24-0032N



OP24-0008N



OP25-0001N

# DOOR ARM ASSEMBLIES & PARTS

## MOVFR CP - DRIVE ARM DRAWINGS

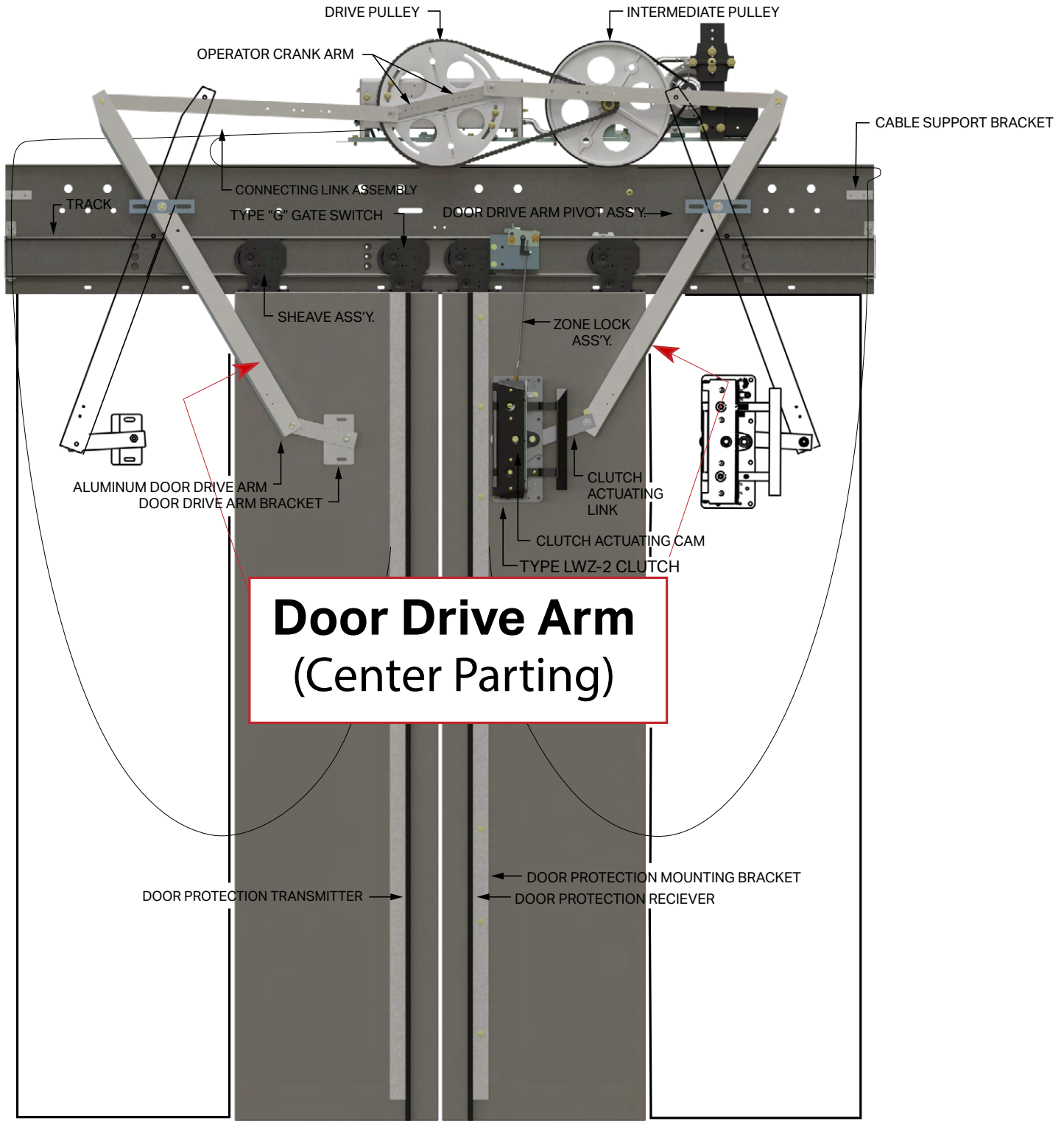

# GATE SWITCHES & RELATED PARTS

PART ID	PART DESCRIPTION
SW-0091N	SWITCH, TYPE"MLS2"PARALLEL MOUNT LIMIT
SW1-0001N	SWITCH ASSEMBLY, GATE
SW1-0003N	CONTACT KIT, G-KT GATE SWITCH
SW1-0044N	SWITCH ASSY, "G" GATE
SW1-0048N	SWITCH ASSY, "G" GATE, MODL & MOVFRII KIT
SW4-0002N	SWITCH, LTD LIMIT DOUBLE CONTACT
SW5-0001N	SWITCH, TYPE "LS" LIMIT 1N.C. CONTACT
SW15-0007L	SWITCH ASSEMBLY, WATER RESISTANT GATE
SW15-0007R	SWITCH ASSEMBLY, WATER RESISTANT GATE
SW21-0111L	LOCK/CONTACT, SN SWING DOOR 4 1/2"CL ARM
SW21-0111R	LOCK/CONTACT, SN SWING DOOR 4 1/2"CL ARM
SW21-0200R	SWITCH ASSEMBLY, SN LOCK SWING DOORS
SW21-0211L	LOCK/CONTACT, SN SWING DOOR 4 1/2"CL ARM
SW21-0211R	LOCK/CONTACT, SN SWING DOOR 4 1/2"CL ARM
SW22-0003N	MAGNET ASSY, LIMIT SWITCH "MLS" RED
SW22-0004N	MAGNET ASSY, LIMIT SWITCH "MLS" GREEN



SW1-0003N



SW1-0048N



SW15-0007L



SW21-0211L



SW22-0003N



SW22-0004N



SW4-0002N

# OPERATOR ISOMETRIC DRAWING MOVFE-HL OPERATOR

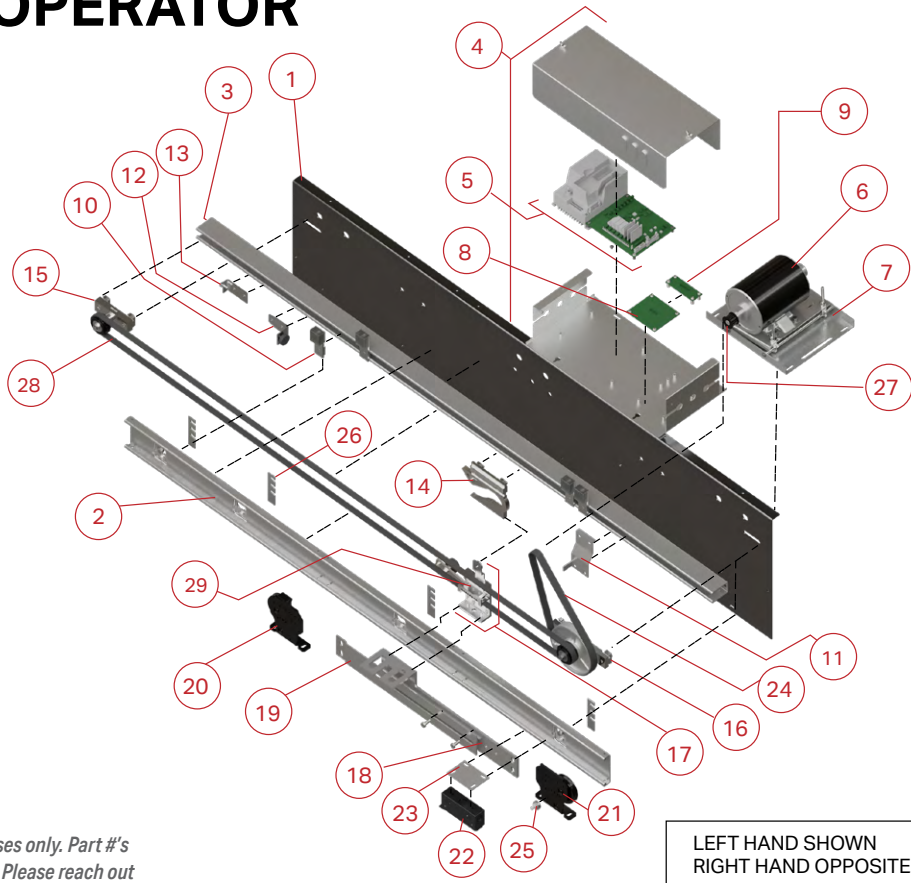

*\*Illustrations are for informational purposes only. Part #'s may have been changed or discontinued. Please reach out to your local representative for more information.*

ITEM NO	PART DESCRIPTION
1	COMBINATION HEADER PLATE
2	HANGER TRACK
3	FIXING STRUT
4	COMPLETE DRIVE UNIT
5	VFE DRIVE UNIT (INCLUDES PARAMETER PART # MOVFE-0008N)
6	1/2 HP MOTOR
7	BASE PIVOT ASSEMBLY
8	I/O BOARD
9	TRANSFER BOARD
10	SENSOR ASSEMBLY
11	KEEPER BRACKET
12	OPEN DOOR STOP
13	TENSION BLOCK
14	CLUTCH CAM

ITEM NO	PART DESCRIPTION
15	TAKE UP PULLEY
16	DRIVE PULLEY
17	LOWER BELT KEEPER BRACKET
18	UNIVERSAL PLATE
19	EXTENSION ARM
20	SHEAVE, RIGHT HAND
21	SHEAVE, LEFT HAND
22	GATE SWITCH TYPE "G"
23	GATE SWITCH MOUNTING PLATE
24	MOTOR "V"-BELT
25	ROLLER & BOLT, GATE SWITCH
26	TRACK SHIMS
27	MULTI- "V" MOTOR PULLEY
28	DRIVE BELT
29	EAGLE BELT BRACKET

# DOOR OPERATORS

## MOVFE-HL

PART ID	PART DESCRIPTION
OPHL1-1505L	MOVFE -HL, SS, 230V, 34-36 D.O.
OPHL1-1505R	MOVFE -HL, SS, 230V, 34-36 D.O.
OPHL1-1507L	MOVFE -HL, SS, 230V, 40-42 D.O.
OPHL1-1507R	MOVFE -HL, SS, 230V, 40-42 D.O.
OPHL3-1503N	MOVFE -HL, CP, 230V, 36-38 D.O.
OPHL3-1505N	MOVFE -HL, CP, 230V, 42-44 D.O.
OPHL3-1507N	MOVFE -HL, CP, 230V, 48-50 D.O.

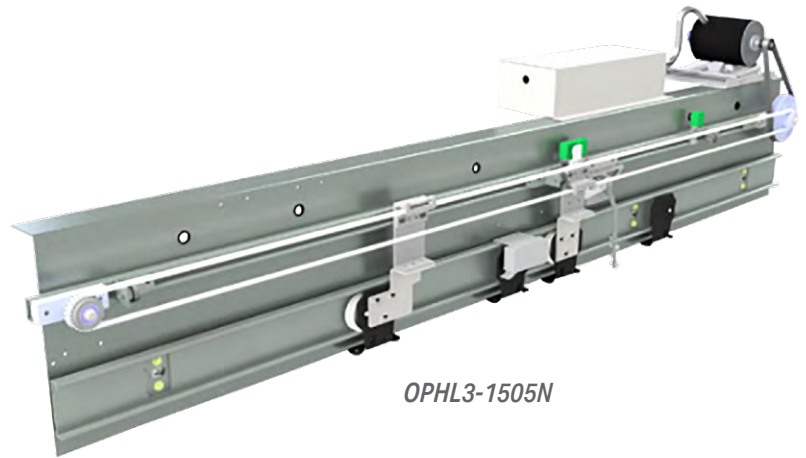

OPHL3-1505N

## MOVFE-HL DOOR OPERATOR PARTS

US PART NO	CANADA PART NO	PART DESCRIPTION
MOVFE-0002N	2500-3050	230V/AC MOVFE BOARD
MOVFE-0003N	2500-3050-1	115V/AC MOVFE BOARD
MOVFE-0008N	2500-3051	PARAMETER UNIT MOVFE/ECI HAND HELD 7FT
OPHL-0120N	2500-5019	SENSOR ASSEMBLY, MOVFE-HL UNIV
HDW-0684N	2500-5026-1	MAGNET, NEODYMIUM, 1.00 X 25
HWBL-0042N	2500-5009	BELT, CHEVRON, 8MM, P X 16MM WIDE, BLK, CUT TO LENGTH, SOLD BY THE METER
HWBL-0044N	2500-2075-1	BELT MULTI-V, 1" MOVFE
HWBL-0045N	2500-2075-2	BELT MULTI-V, 2" MOVFE
HWBL-0046N	2500-2075-3	BELT MULTI-V, 3" MOVFE
HWBL-0047N	2500-2075-4	BELT MULTI-V, 4" MOVFE
HWBL-0048N	2500-2075-5	BELT MULTI-V, 5" MOVFE
OPHL-0113N	2500-3084	CLUTCH CAM ASSEMBLY

# DOOR EQUIPMENT CAR DOOR HANGER SS DRAWING

**SINGLE SPEED - TYPE "A"  
22"- 48" DOOR OPENING**

**FRONT BUMPER**  
(Optional, required for  
"HA" hangers)

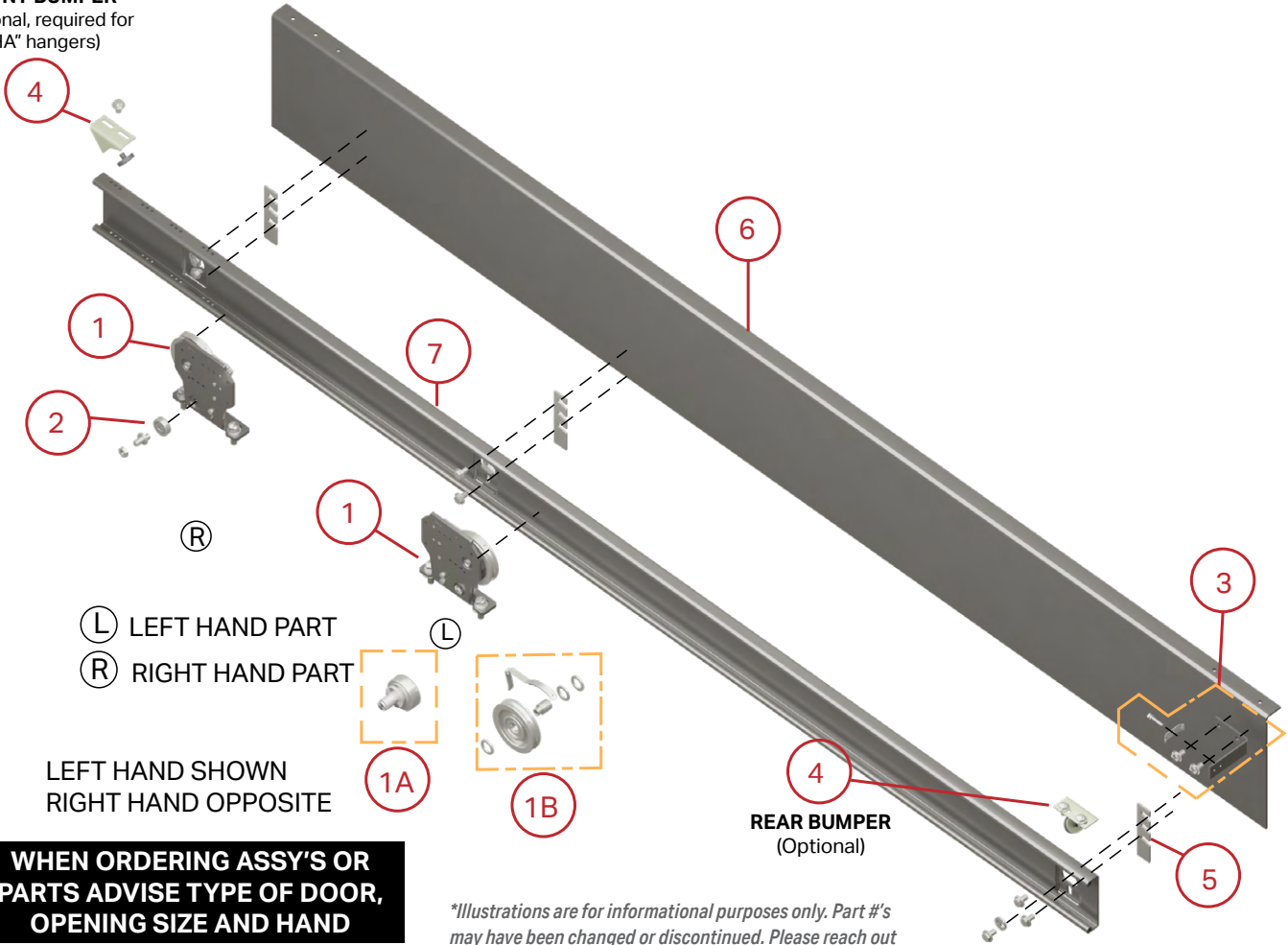

(L) LEFT HAND PART  
(R) RIGHT HAND PART

LEFT HAND SHOWN  
RIGHT HAND OPPOSITE

**WHEN ORDERING ASSY'S OR  
PARTS ADVISE TYPE OF DOOR,  
OPENING SIZE AND HAND**

*\*Illustrations are for informational purposes only. Part #'s  
may have been changed or discontinued. Please reach out  
to your local representative for more information.*

PART NO.	ITEM NO.	PART DESCRIPTION
HH1-0022L/R	1	SHEAVE, 4-1/8 CL WITH 3/8-16 BOLTS
HH1-0024N	1A	ECCENTRIC, "A" SHEAVE
HH1-0025N	1B	ROLLER KIT, 3 1/4" DIA "A"
SW1-0007N	2	ROLLER & BOLT, GATE SWITCH
CDH1-0020N	3	CLAMP, S/S-C/P HANGER SAFETY EDGE CABLE

PART NO.	ITEM NO.	PART DESCRIPTION
HH4-0055N	4	BUMPER, "A" CP ASSEMBLY STOP
HH1-0032N	5	SPACER, 1/8" TRACK
CDH1-0144L/R	6	HEADER, A-HANGER S/S 22"-48" D.O. CAR
CDH1-XXXX	7	TRACK, S/S CAR DOOR

# CONVERSION KITS

## MOVFE-HL FOR THE QKS16 AND IDD LINEAR SERIES OPERATORS

PART ID	PART DESCRIPTION
KIT01-5001N	QKS16VF to MOVFE-HL KIT - 230 Volts
KIT01-5002N	QKS16 to MOVFE-HL KIT - 115 Volts

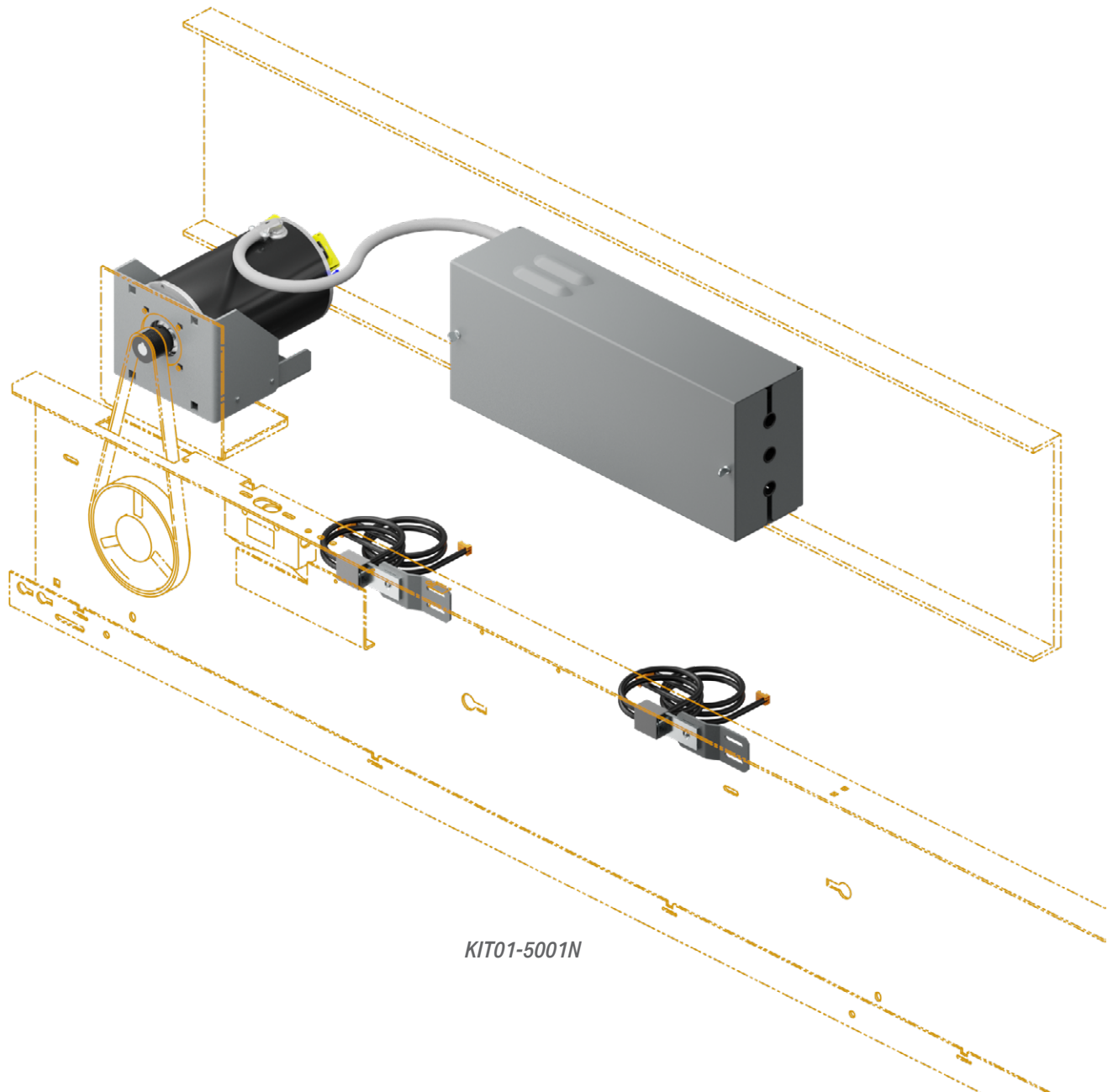

KIT01-5001N

# DOOR EQUIPMENT MODERNIZATION KITS

## **GAL COMPACT MOVFR-II**

Designed for installing a GAL Operator in limited cartop space in Dover IVO Jack Cartop. Allows for easy installation of GAL operators where there is an existing Dover hydraulic piston in the cartop. Adjustable components so that only one part number is needed for an opening regardless of size.

## **DOVER HATCH UNISTRUT TO GAL HATCH HANGER ASSEMBLY ADAPTOR KIT**

Designed for installing GAL "A" tracks in existing Dover unistrut hoistways. Allows for easy installation of GAL hatch tracks where there are existing Dover hatch hanger assemblies with unistrut welded to the hatch header. Includes all necessary hardware for installation.

## **GAL CONVERSION KIT MOVFE-HH to replace existing SEC QKS14 and QKS15 Operators**

Replaces a Schindler QKS-14 or QKS-15 operator with GAL's MOVFE-HH operator. The mechanical profile of the MOVFE-HH is identical to the existing QKS operator. The header, tracks and hangers are retained, allowing the user to easily replace the operator with minimal adjustments required. When properly installed, GAL door operators will give many years of trouble-free service and reliability.

## **GAL UNIVERSAL OPERATOR AND HEADER MOUNTING KITS**

Designed for all GAL Operators and Car Door Headers. Allows for easy installation of GAL headers and operators to the transom and cartop during modernization. Eliminates need for additional brackets from outside vendors and has provisions for all GAL headers and operators.

## **GAL UNIVERSAL INTERLOCK MOUNTING KIT**

Designed for installing a GAL MOH or MOCPPH interlock system in most existing hoistways. Allows for easy installation of GAL interlocks where there are existing non-GAL hatch hanger assemblies. Includes all necessary hardware for installation.

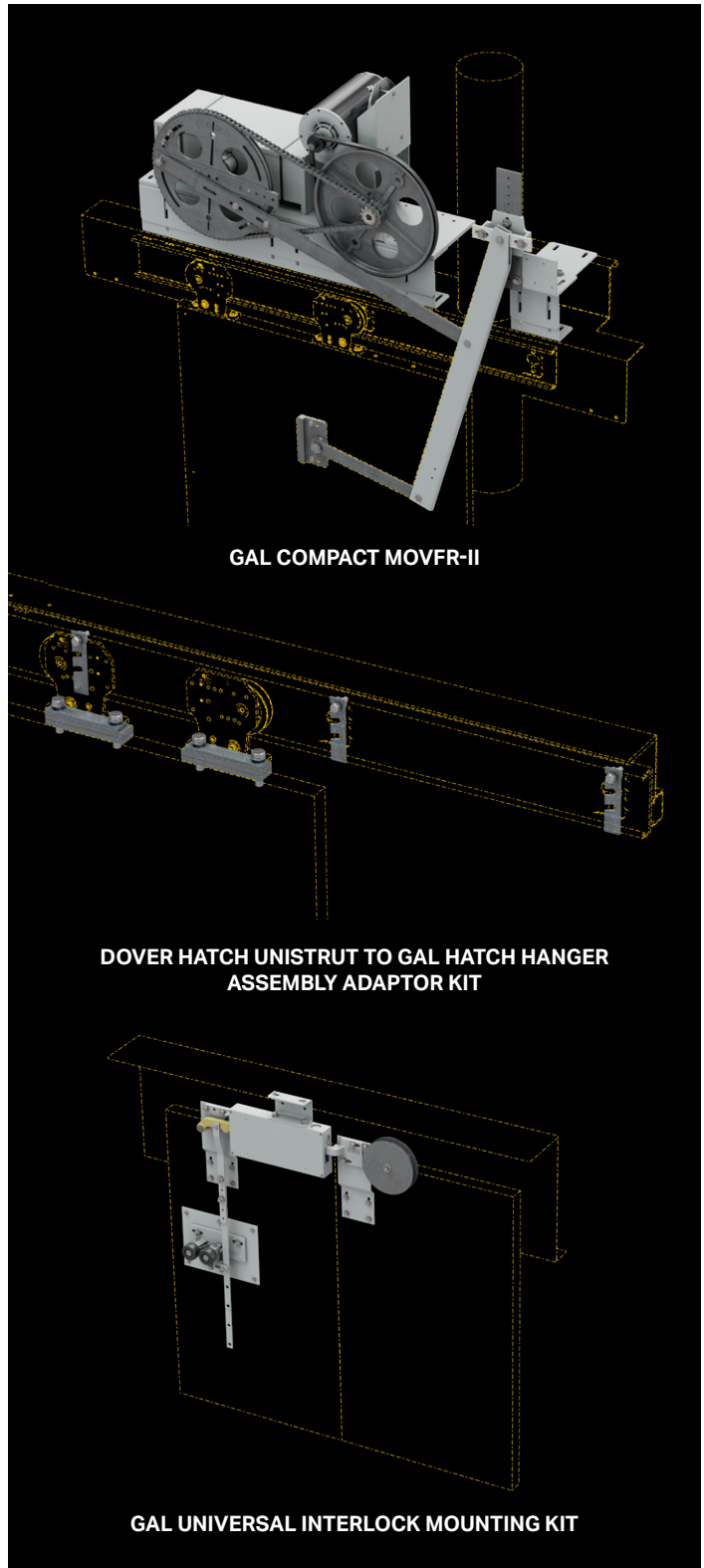

**GAL COMPACT MOVFR-II**

**DOVER HATCH UNISTRUT TO GAL HATCH HANGER ASSEMBLY ADAPTOR KIT**

**GAL UNIVERSAL INTERLOCK MOUNTING KIT**

# DOOR EQUIPMENT MODERNIZATION KITS CONTINUED

## **GAL CONVERSION KIT OTIS OVL to GAL MOVFE-HH**

This retrofit kit replaces an OTIS OVL operator with GAL's MOVFE-HH operator. The mechanical profile of the MOVFE-HH is like the existing Otis OVL operator. The drive arms, header, tracks, and hangers are retained, allowing the user to easily replace the operator with minimal adjustments required.

## **GAL CONVERSION KIT MOVFE-HL to Replace SEC QKS16 Linear and IDD Operators**

This retrofit kit replaces the drive components of an SEC QKS16 or IDD operator with GAL's MOVFE-HL operator. The existing QKS16 header, tracks and hangers are retained, allowing the user to easily replace the motor and add door sensors and controls instead of removing the entire header assembly and rehanging the doors.

## **GAL CONVERSION KIT Westinghouse Integral to GAL**

This kit converts an elevator entrance from Westinghouse Integral door/track equipment to GAL steel tracks and standard door rollers. This kit allows installers to retain hatch doors and headers and install GAL equipment without the need to cut off the door hanger portion of the existing Westinghouse Integral Door.

## **GAL WESTINGHOUSE INTERLOCK MOUNTING KIT**

Designed for installing a GAL MOH or MOCPH Interlock System in existing Westinghouse Integral. Allows for easy installation of GAL interlocks where there are existing non-GAL hatch hanger assemblies. Includes all necessary hardware for installation.

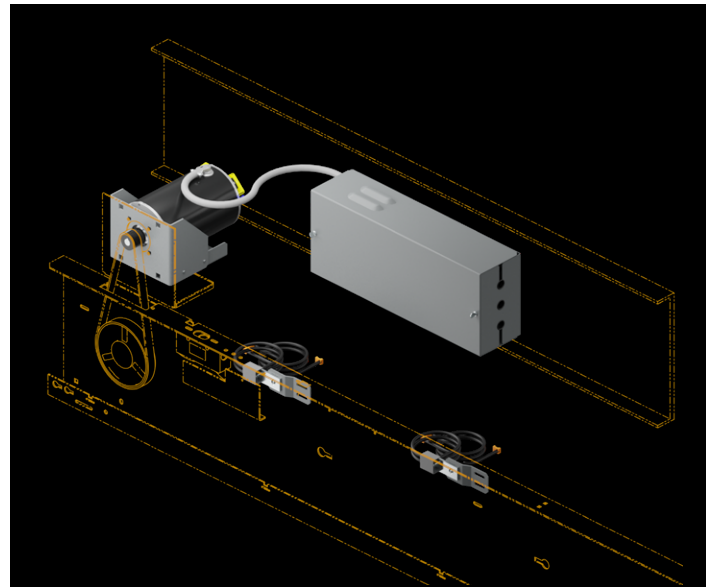

**MOVFE-HL to Replace SEC QKS16 Linear  
and IDD Operators**

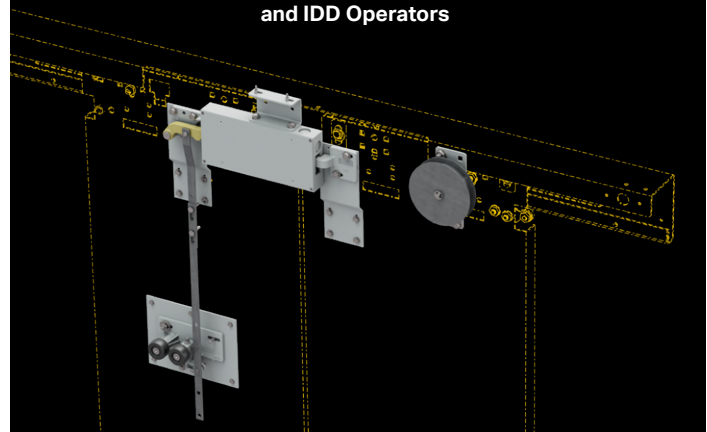

**GAL WESTINGHOUSE INTERLOCK MOUNTING KIT**



**Westinghouse Integral to GAL**

# DOOR EQUIPMENT MODERNIZATION KITS CONTINUED

## CAR SIDE EQUIPMENT

PART NO.	UNIVERSAL OPERATOR MOUNT KITS
KIT00-0101N	HEADER MOUNT KIT, UNIVERSAL
KIT00-0102N	OPERATOR MOUNT KIT, UNIVERSAL
KIT00-0103N	HEADER/OPERATOR MOUNT KIT, UNIVERSAL

PART NO.	QKS16 MODERNIZATION KITS
KIT01-5001N	QKS16VF/IDD TO MOVFE-HL KIT, 230V, 1E
KIT01-5002N	QKS16/IDD TO MOVFE-HL KIT, 115V, 1E

PART NO.	QKS14/15 MODERNIZATION KITS
KIT03-4001L	QKS14/15 to MOVFE HH KIT, SS/2S, 115V
KIT03-4001R	QKS14/15 to MOVFE HH KIT, SS/2S, 115V
KIT03-4003N	QKS14/15 to MOVFE HH KIT, CP, 115V

PART NO.	OVL MODERNIZATION KIT
KIT04-4001L	OVL to MOVFE HH KIT, 115V
KIT04-4001R	OVL to MOVFE HH KIT, 115V
KIT04-4002L	OVL to MOVFE HH KIT, 230V
KIT04-4002R	OVL to MOVFE HH KIT, 230V

PART NO.	IVO JACK MODERNIZATION KIT
KIT05-4001L	IVO JACK TO MOVFR II KIT, SS/2S, 115V
KIT05-4001R	IVO JACK TO MOVFR II KIT, SS/2S, 115V
KIT05-4002L	IVO JACK TO MOVFR II KIT, SS/2S, 230V
KIT05-4002R	IVO JACK TO MOVFR II KIT, SS/2S, 230V

## HATCH SIDE EQUIPMENT

PART NO.	UNIVERSAL LOCKS
KIT00-0201L	KIT, LOCK/CLOSER UNIV, SS/2S
KIT00-0201R	KIT, LOCK/CLOSER UNIV, SS/2S
KIT00-0202L	KIT, LOCK UNIV, SS/2S
KIT00-0202R	KIT, LOCK UNIV, SS/2S
KIT00-0203N	KIT, LOCK/CLOSER UNIV, CP
KIT00-0204N	KIT, LOCK UNIV, CP

PART NO.	DOVER UNISTRUT HDW KIT
KIT05-2001N	DOVER STRUT TO GAL HATCH HDW KIT, SS
KIT05-2002N	DOVER STRUT TO GAL HATCH HDW KIT, CP/2S

PART NO.	WESTINGHOUSE HATCH SIDE EQUIPMENT
WHH-0301L	KIT, LOCK/CLOSER WH INTEGRAL, SS/2S
WHH-0301R	KIT, LOCK/CLOSER WH INTEGRAL, SS/2S
WHH-0302L	KIT, LOCK WH INTEGRAL, SS/2S
WHH-0302R	KIT, LOCK WH INTEGRAL, SS/2S
WHH-0303N	KIT, LOCK/CLOSER WH INTEGRAL, CP
WHH-0304N	KIT, LOCK WH INTEGRAL, CP

# DOOR EQUIPMENT MODERNIZATION KITS CONTINUED

## HATCH SIDE EQUIPMENT

PART NO. WESTINGHOUSE HATCH SIDE EQUIPMENT	
<b>SIDE SLIDE HANGER ASSEMBLY</b>	
WHH1-0001N	HANGER, WH-SS 22"-24" D.O. HATCH*
WHH1-0002N	HANGER, WH-SS 25"-27" D.O. HATCH*
WHH1-0003N	HANGER, WH-SS 28"-30" D.O. HATCH*
WHH1-0004N	HANGER, WH-SS 31"-33" D.O. HATCH*
WHH1-0005N	HANGER, WH-SS 34"-36" D.O. HATCH*
WHH1-0006N	HANGER, WH-SS 37"-39" D.O. HATCH*
WHH1-0007N	HANGER, WH-SS 40"-42" D.O. HATCH*
WHH1-0008N	HANGER, WH-SS 43"-45" D.O. HATCH*
WHH1-0009N	HANGER, WH-SS 46"-48" D.O. HATCH*
WHH1-0010N	HANGER, WH-SS 49"-52" D.O. HATCH*
WHH1-0011N	HANGER, WH-SS 53"-56" D.O. HATCH*
WHH1-0012N	HANGER, WH-SS 57"-60" D.O. HATCH*
<b>CENTER PARTING HANGER ASSEMBLY</b>	
WHH3-0001N	HANGER, WH-CP 30"-32" D.O. HATCH*
WHH3-0002N	HANGER, WH-CP 33"-35" D.O. HATCH*
WHH3-0003N	HANGER, WH-CP 36"-38" D.O. HATCH*
WHH3-0004N	HANGER, WH-CP 39"-41" D.O. HATCH*
WHH3-0005N	HANGER, WH-CP 42"-44" D.O. HATCH*
WHH3-0006N	HANGER, WH-CP 45"-47" D.O. HATCH*
WHH3-0007N	HANGER, WH-CP 48"-50" D.O. HATCH*
WHH3-0008N	HANGER, WH-CP 51"-53" D.O. HATCH*
WHH3-0009N	HANGER, WH-CP 54"-56" D.O. HATCH*
WHH3-0010N	HANGER, WH-CP 57"-59" D.O. HATCH*
WHH3-0011N	HANGER, WH-CP 60"-64" D.O. HATCH

PART NO. WESTINGHOUSE PANEL KIT	
WHH-0101N	SS Panel Kit
WHH-0102N	CP Panel Kit

PART NO. WESTINGHOUSE TRACK KITS	
WHH-2005N	71" long for a 36" SS opening
WHH-2007N	83" long for a 42" SS opening
WHH-2015N	36" long for a 36" CP opening, 2 required per opening
WHH-2017N	36" long for a 42" CP opening, 2 required per opening
WHH-2019N	36" long for a 48" CP opening, 2 required per opening

# LWL CLUTCH CAR DOOR INTERLOCK

## RETROFITTABLE GAL CAR DOOR INTERLOCK AND LWL CLUTCH

When it comes to the riding public, safety has always been our number one priority. With the release of the LWL Clutch and Car Door Interlock package, we build upon that reputation. This Car Door Interlock adds another level of protection that lessens the chance of human error and circumvention when it comes to keeping the car door closed during operation. Designed to work with the GAL MOVFR II Harmonic Door Operator, this package can easily be retrofit to existing installations.

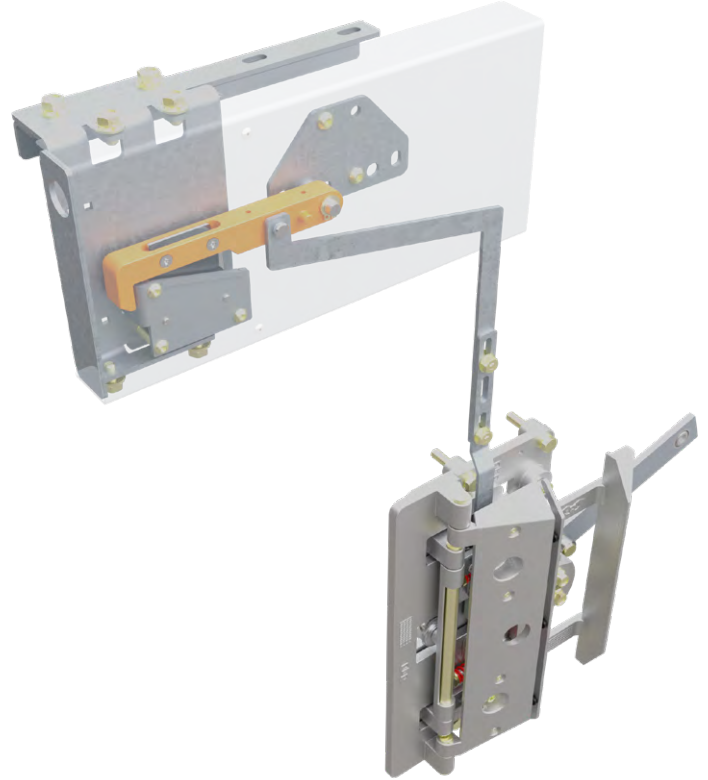

### BENEFITS & STANDARD FEATURES

- UL certified to ASME A17.1-2019 for the US and Canada
- Greatly reduces the chance of circumvention of safety devices
- LWL Car Door Interlock eliminates the need for fascia on blind hoistways
- Combines the functionality of a gate switch and a zone lock into one device
- Compatible with standard GAL MOH and MOCPH hatch equipment and locks
- LWL clutch is an upgraded drop in replacement for the LWZ-2 clutch
- Follows standard GAL templates

The **LWL Clutch and Interlock** is designed to work with the MOVFR2 series of Harmonic operators and standard MOH and MOC PH Hoistway interlock packages. The clutch and the car door interlock are packaged to be ordered separately depending on your job's specific needs. The series covers the full range of our **Standard and LOW Clutches** (Sorry, no LRC model is available at this time). The LWL Clutch comes in the following styles: Standard, Water Resistant (Clutch Only), and Vandal Resistant\* (Clutch only).

<b>SIDE SLIDE</b>								
<b>LWL CLUTCHES</b>								
Door Openings			Link Size	STANDARD		LOW		
(SS)	(2S)	(3S)		STANDARD	Water Resistant	STANDARD	Water Resistant	
	24-26	30-34	5 1/4"	CLU23-0000L/R	CLU23-0020L/R	CLU23-0010L/R	CLU23-0030L/R	
30-34	27-34	35-39	6"	CLU23-0001L/R	CLU23-0021L/R	CLU23-0011L/R	CLU23-0031L/R	
35-39	35-39	40-44	8"	CLU23-0003L/R	CLU23-0023L/R	CLU23-0013L/R	CLU23-0033L/R	
		45-49	9"	CLU23-0004L/R	CLU23-0024L/R	CLU23-0014L/R	CLU23-0034L/R	
22-29, 40-44	40-44		10"	CLU23-0005L/R	CLU23-0025L/R	CLU23-0015L/R	CLU23-0035L/R	
		50-54	11"	CLU23-0006L/R	CLU23-0026L/R	CLU23-0016L/R	CLU23-0036L/R	
45-48	45-56	55-59	12"	CLU23-0007L/R	CLU23-0027L/R	CLU23-0017L/R	CLU23-0037L/R	
	57-64	60-64	14"	CLU23-0008L/R	CLU23-0028L/R	CLU23-0018L/R	CLU23-0038L/R	
	65-72	65-69	16"	CLU23-0009L/R	CLU23-0029L/R	CLU23-0019L/R	CLU23-0039L/R	
<b>LWL CAR DOOR INTERLOCKS</b>								
(SS)			(2S)			(3S)		
Door Opening	STANDARD	LOW	Door Opening	STANDARD	LOW	Door Opening	STANDARD	LOW
22-29	CDI-0001L/R	CDI-0008L/R	30-39	CDI-0016L/R	CDI-0023L/R	30-54	CDI-0032L/R	CDI-0039L/R
30-39	CDI-0002L/R	CDI-0009L/R	24-29, 40-44	CDI-0017L/R	CDI-0024L/R	55-64	CDI-0033L/R	CDI-0040L/R
40-44	CDI-0003L/R	CDI-0010L/R	45-52	CDI-0018L/R	CDI-0025L/R	65-69	CDI-0034L/R	CDI-0041L/R
45-48	CDI-0004L/R	CDI-0011L/R	53-60	CDI-0019L/R	CDI-0026L/R			
			61-68	CDI-0020L/R	CDI-0027L/R			
			69-72	CDI-0021L/R	CDI-0028L/R			

<b>CENTER PARTING</b>						
<b>LWL CLUTCHES</b>						
Door Openings		Link Size	STANDARD		LOW	
(CP)	(2SCP)		STANDARD	Water Resistant	STANDARD	Water Resistant
24-33	32-49	5 1/4"	CLU23-0050L/R	CLU23-0070L/R	CLU23-0060L/R	CLU23-0080L/R
34-49	50-59	6"	CLU23-0051L/R	CLU23-0071L/R	CLU23-0061L/R	CLU23-0081L/R
60-67	60-67	7"	CLU23-0052L/R	CLU23-0072L/R	CLU23-0062L/R	CLU23-0082L/R
50-59, 68-74	68-74	8"	CLU23-0053L/R	CLU23-0073L/R	CLU23-0063L/R	CLU23-0083L/R
75-79	75-79	9"	CLU23-0054L/R	CLU23-0074L/R	CLU23-0064L/R	CLU23-0084L/R
80-83	80-83	10"	CLU23-0055L/R	CLU23-0075L/R	CLU23-0065L/R	CLU23-0085L/R
<b>LWL CAR DOOR INTERLOCKS</b>						
(CP)			(2SCP)			
Door Opening	STANDARD	LOW	Door Opening	STANDARD	LOW	
20-39	CDI-0043N	CDI-0050N	32-39	CDI-0057N	CDI-0064N	
40-49	CDI-0044N	CDI-0051N	40-49	CDI-0058N	CDI-0065N	
50-59	CDI-0045N	CDI-0052N	50-59, 84-90	CDI-0059N	CDI-0066N	
60-79	CDI-0046N	CDI-0053N	60-79, 91-106	CDI-0060N	CDI-0067N	
80-83	CDI-0047N	CDI-0054N	80-83, 107-110	CDI-0061N	CDI-0068N	

\*Contact G.A.L. for Vandal Resistant Clutch arrangements.



PART ID	PART DESCRIPTION
CDH1-0004L	HANGER, A-SS 31"-33" D.O. CAR
CDH1-0004R	HANGER, A-SS 31"-33" D.O. CAR
CDH1-0005L	HANGER, A-SS 34"-36" D.O. CAR
CDH1-0005R	HANGER, A-SS 34"-36" D.O. CAR
CDH1-0006L	HANGER, A-SS 37"-39" D.O. CAR
CDH1-0007L	HANGER, A-SS 40"-42" D.O. CAR
CDH1-0007R	HANGER, A-SS 40"-42" D.O. CAR
CDH1-0008L	HANGER, A-SS 43"-44" D.O. CAR
CDH1-0008R	HANGER, A-SS 43"-44" D.O. CAR
CDH1-0100L	TRACK, A-SS 37"-39" D.O. 76"LG CAR
CDH1-0100R	TRACK, A-SS 37"-39" D.O. 76"LG CAR
CDH1-0102L	TRACK, A-SS 43"-45" D.O. 88"LG CAR
CDH1-0102R	TRACK, A-SS 43"-45" D.O. 88"LG CAR
CDH2-0008R	HANGER, A-2S 43"-44" D.O. CAR GEARED
CDH2-0010L	HANGER, A-2S 47"-48" D.O. CAR GEARED
CDH2-0078N	CABLE ASSY, GEARING, 2S, 45" - 48" D.O.
CDH2-0079N	PULLEY ASSEMBLY, 2SP GEARING STEEL
CDH3-0003N	HANGER, A-CP 36"-38" D.O. CAR UNGEARED
CDH3-0004N	HANGER, A-CP 39"-41" D.O. CAR UNGEARED
CDH3-0005N	HANGER, A-CP 42"-44" D.O. CAR UNGEARED
CDH3-0007N	HANGER, A-CP 48"-49" D.O. CAR UNGEARED
CDH3-0295R	SHEAVE, 4.125 CL 3/8-16 C/P V. GEAR*



CDH2-0078N



CDH1-0005L

# DOOR EQUIPMENT CAR DOOR HANGER

CENTER PARTING - TYPE "A"  
30" - 59" DOOR OPENING

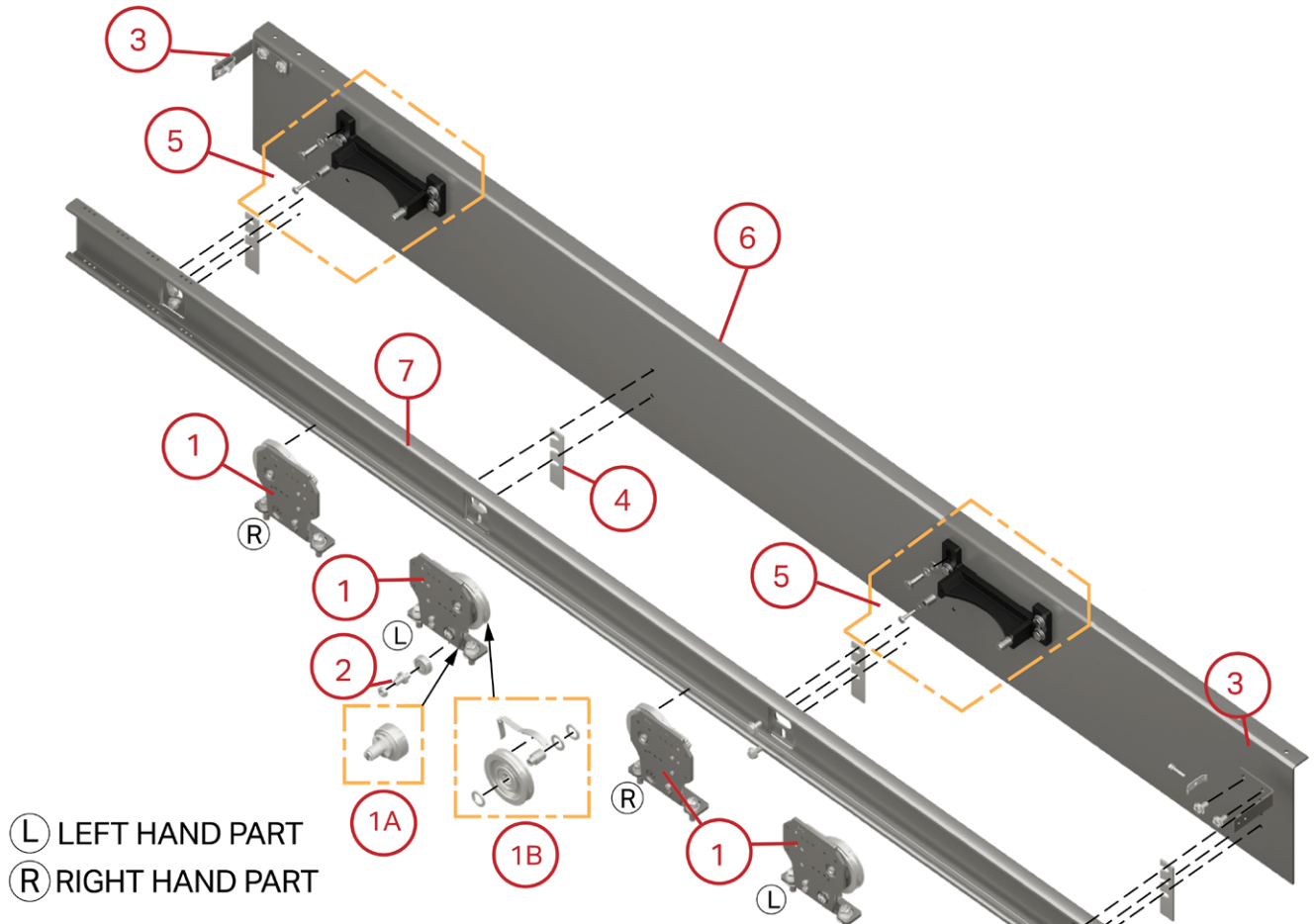

(L) LEFT HAND PART  
(R) RIGHT HAND PART

**WHEN ORDERING ASSY'S OR PARTS ADVISE TYPE OF DOOR, OPENING SIZE AND HAND**

*\*Illustrations are for informational purposes only. Part #'s may have been changed or discontinued. Please reach out to your local representative for more information.*

PART NO.	ITEM NO.	PART DESCRIPTION
HH1-0022L/R	1	SHEAVE, 4-1/8 CL WITH 3/8-16 BOLTS
HH1-0024N	1A	ECCENTRIC, "A" SHEAVE
HH1-0025N	1B	ROLLER KIT, 3 1/4" DIA "A"
SW1-0007N	2	ROLLER & BOLT, GATE SWITCH
CDH1-0020N	3	CLAMP, S/S-C/P HANGER SAFETY EDGE CABLE

PART NO.	ITEM NO.	PART DESCRIPTION
HH4-0055N	4	BUMPER, "A" CP ASSEMBLY STOP
OP25-0001N	5	BRACKET, C/P ARM SUPPORT
CDH3-0290N	6	HEADER, A-HANGER CP S4"-59" D.O. CAR
CDH3-XXXX	7	TRACK, C/P CAR DOOR

# CLUTCH KITS, LINKS, & LOCKING ASSEMBLIES

PART ID	PART DESCRIPTION
CLU1-0053N	SPACER, CLUTCH 1/8 THICK
CLU1-0054N	SPACER, CLUTCH 1/16 THICK
CLU3-0331L	CAM, LWZ-1 STANDARD LOCKING ASSY
CLU3-0331R	CAM, LWZ-1 STANDARD LOCKING ASSY
CLU3-0358N	PLATE, STANDARD CLUTCH REINFORCEMENT
CLU1-0053N	SPACER, CLUTCH 1/8 THICK
CLU1-0054N	SPACER, CLUTCH 1/16 THICK
CLU3-0331L	CAM, LWZ-1 STANDARD LOCKING ASSY
CLU3-0331R	CAM, LWZ-1 STANDARD LOCKING ASSY
CLU3-0358N	PLATE, STANDARD CLUTCH REINFORCEMENT
CLU9-0001L	CLUTCH, LWZ-2 10" LINK W/24" ROD
CLU9-0001R	CLUTCH, LWZ-2 10" LINK W/24" ROD
CLU9-0002L	CLUTCH, LWZ-2 6" LINK W/24" ROD
CLU9-0002R	CLUTCH, LWZ-2 6" LINK W/24" ROD
CLU9-0003L	CLUTCH, LWZ-2 8" LINK W/24" ROD
CLU9-0003R	CLUTCH, LWZ-2 8" LINK W/24" ROD
CLU9-0004L	CLUTCH, LWZ-2 12" LINK W/24" ROD
CLU9-0004R	CLUTCH, LWZ-2 12" LINK W/24" ROD
CLU9-0005L	CLUTCH, LWZ-2 5 1/4" LINK W/24" ROD
CLU9-0005R	CLUTCH, LWZ-2 5 1/4" LINK W/24" ROD
CLU9-0013L	CLUTCH, LWZ-2-LOW 10" LINK W/ 24" ROD
CLU9-0013R	CLUTCH, LWZ-2-LOW 10" LINK W/24" ROD
CLU9-0014L	CLUTCH, LWZ-2-LOW 6" LINK W/24" ROD
CLU9-0014R	CLUTCH, LWZ-2-LOW 6" LINK W/24" ROD
CLU9-0015L	CLUTCH, LWZ-2-LOW 8" LINK W/24" ROD
CLU9-0015R	CLUTCH, LWZ-2-LOW 8" LINK W/24" ROD
CLU9-0016L	CLUTCH, LWZ-2-LOW 12" LINK W/24" ROD
CLU9-0016R	CLUTCH, LWZ-2-LOW 12" LINK W/24" ROD
CLU9-0017L	CLUTCH, LWZ-2-LOW 5 1/4" LINK W/24" ROD
CLU9-0017R	CLUTCH, LWZ-2-LOW 5 1/4" LINK W/24" ROD
CLU9-0049L	CAM ASSEMBLY, LWZ-2 STANDARD LOCKING
CLU9-0049R	CAM ASSEMBLY, LWZ-2 STANDARD LOCKING
CLU9-0063N	LINK, CLUTCH 5 1/4"CL LWZ-2-LOW/LWZ-2-LRC
CLU9-0064N	LINK, CLUTCH 6"CL LWZ-2-LOW/LWZ-2-LRC
CLU9-0066N	LINK, CLUTCH 8"CL LWZ-2-LOW/LWZ-2-LRC
CLU9-0068N	LINK, CLUTCH 10"CL LWZ-2-LOW/LWZ-2-LRC
CLU9-0070N	LINK, CLUTCH 12"CL LWZ-2-LOW/LWZ-2-LRC
CLU9-0083N	LINK, CLUTCH 5 1/4"CL STANDARD LWZ-2/LW-2
CLU9-0084N	LINK, CLUTCH 6"CL STANDARD LWZ-2/LW-2
CLU9-0086N	LINK, CLUTCH 8"CL STANDARD LWZ-2/LW-2
CLU9-0088N	LINK, CLUTCH 10"CL STANDARD LWZ-2/LW-2
CLU9-0090N	LINK, CLUTCH 12"CL STANDARD LWZ-2/LW-2
CLU9-0094N	ROD, 24" LWZ-2 CLUTCH ZONE LOCKING
CLU9-0111N	CAM, LWZ-2, LW-2 & L-2 CLUTCH ACTUATING
CLU9-0113N	ROLLER, 1 1/4" DIA LWZ-2, LW-2 OR L-2
CLU9-0115L	LOCKING ASSEMBLY, LWZ-2 CLUTCH ZONE 36"
CLU9-0115R	LOCKING ASSEMBLY, LWZ-2 CLUTCH ZONE, 36"
CLU9-0256N	ARM, LWZ-2 RETRACTING ASSEMBLY
CLU9-0260N	ROD, SPECIAL _____" LWZ-2 ZONE LOCKING



CLU1-0053N



CLU3-0331L



CLU3-0358N



CLU9-0260N

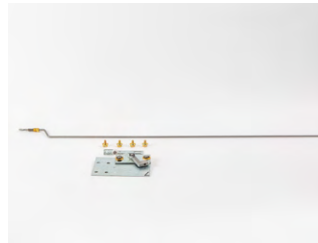

CLU9-0015R



CLU9-0066N



CLU9-0113N

# CLUTCH RUNNING CLEARANCE

## CHOOSING CLUTCH ARRANGEMENT

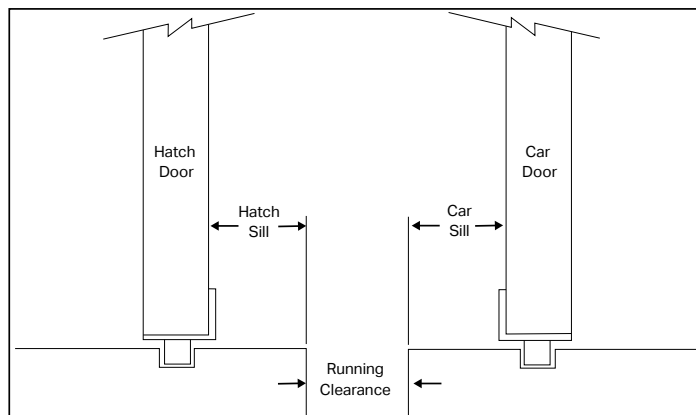
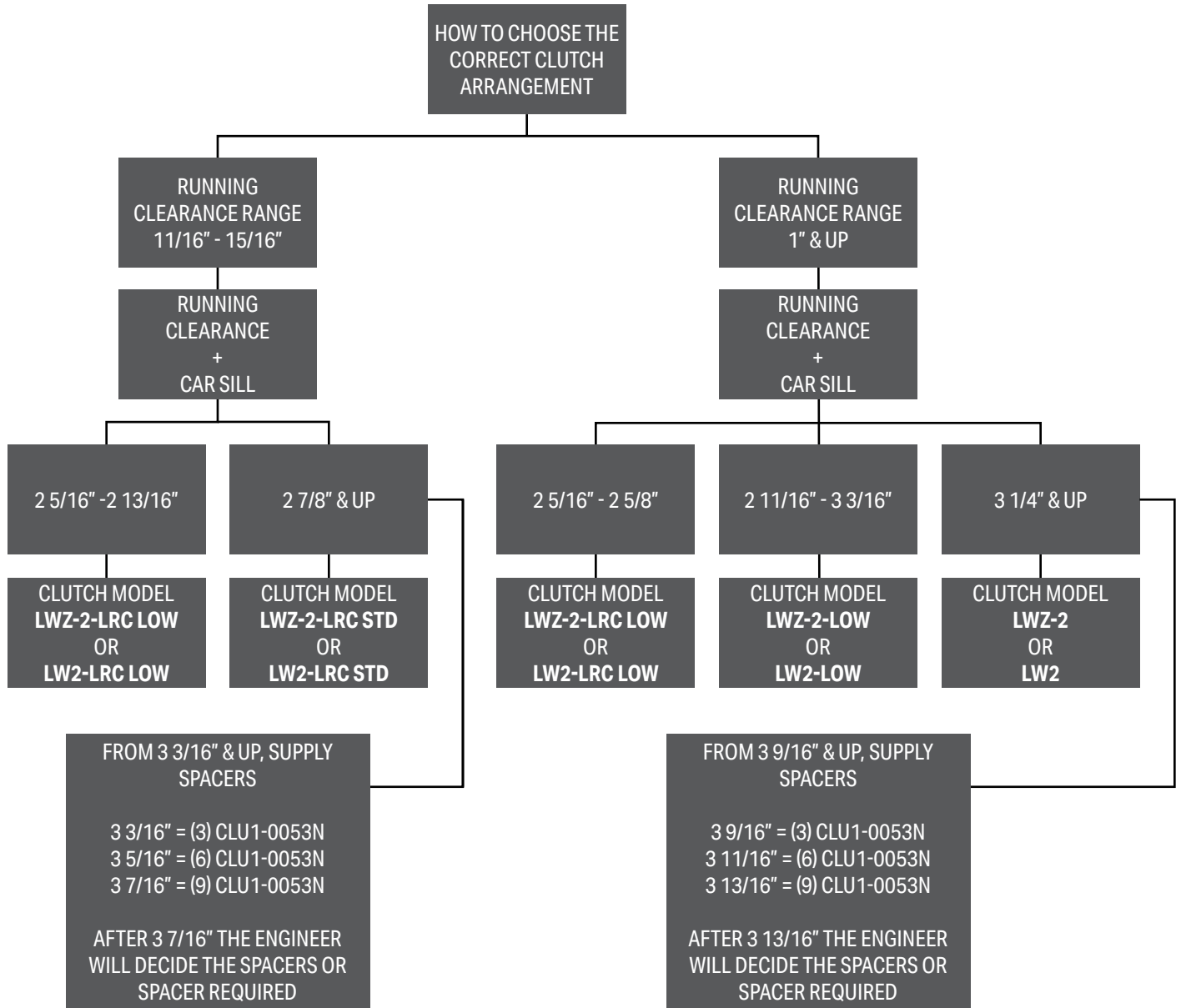

# DOOR EQUIPMENT CLUTCH ASSEMBLY

## LWZ-2 SERIES W/ CAR ZONE LOCKING ASSEMBLY DRIVE ARM ACTUATED CLUTCH

USE WITH HORIZONTAL ROLLER RELEASE

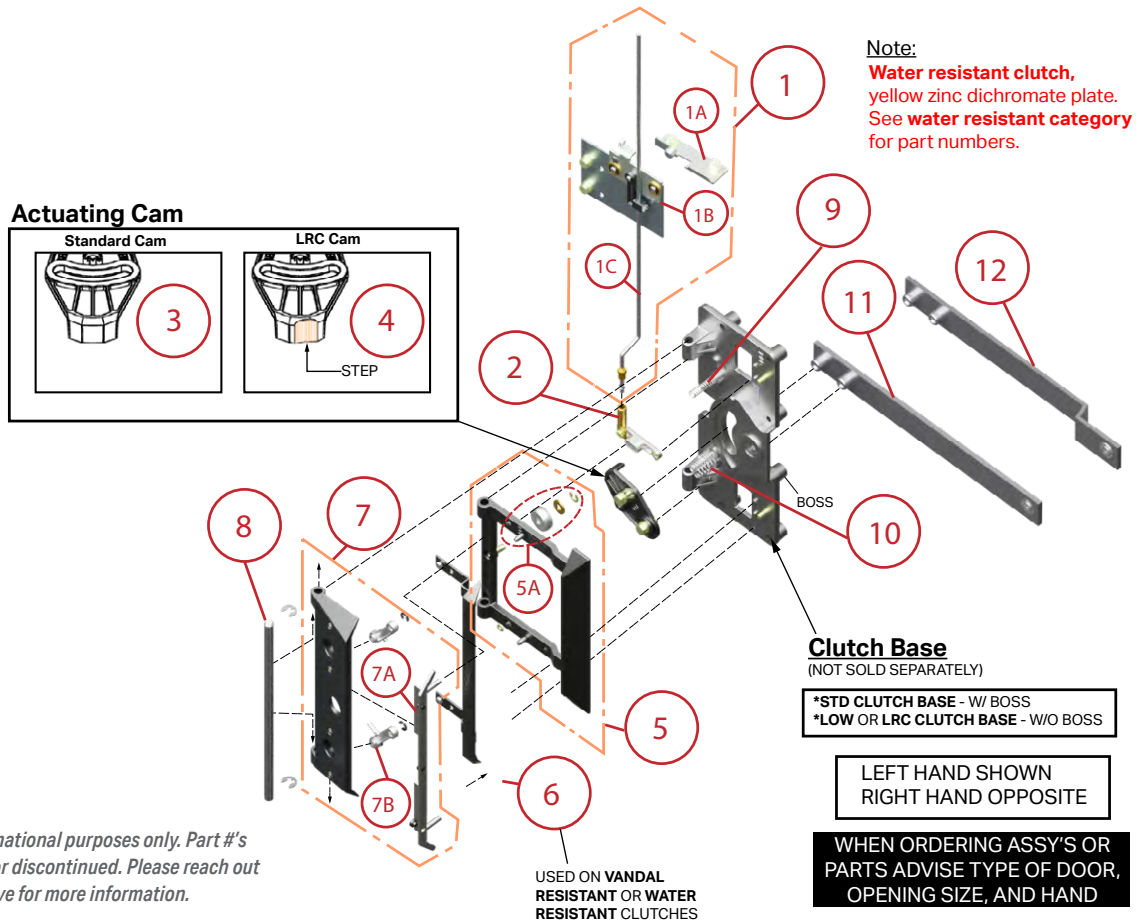

\*Illustrations are for informational purposes only. Part #'s may have been changed or discontinued. Please reach out to your local representative for more information.

PART NO.	ITEM NO.	PART DESCRIPTION	PART NO.	ITEM NO.	PART DESCRIPTION
CLU9-0115L/R	1	ZONE LOCKING ASSEMBLY, LWZ-2 CLUTCH 36" ROD	CLU9-0103N	6	VANE, LWZ-2-HA CLUTCH FIXED
CLU9-0049L/R	1A	CAM, LWZ-2 STANDARD LOCKING, INCLUDES HARDWARE	CLU9-0257L/R	7	VANE, LWZ-2 DOOR OPEN
CLU9-0101L/R	1B	GUIDE, LWZ-2 CLUTCH LOCKING ROD, 24"/36" LWZ-2 CLUTCH ZONE LOCKING	CLU9-0255N	7A	SENSING BAR & PIVOT, LWZ-2 ZONE LOCK, WITH (2) 1 9/32" LONG PINS
*CLU9-XXXXX	1C		SPG-0081N	7B	SPRING, 7/8" LG X 1/4" O.D. (.024 WIRE - 9 TURNS)
CLU9-0256N	2	ARM, LWZ-2 RETRACTING ASSEMBLY CAM, CLUTCH ACTUATING, LWZ-2 & LWZ-2-LOW, STANDARD	SHF-0065N	8	SHAFT, 7/16" X 11 7/8" LG LWZ-2 OPEN VANE
CLU9-0111N	3	CAM, LW-2-LRC/LWZ-2-LRC CLUTCH ACTUATING	SPG-0019N	9	SPRING, 1 5/8" LG X 3/8 O.D. (.037 WIRE - 14 TURNS)
CLU9-0238L/R	4		SPG-0036N	10	SPRING, 1 1/4" LG X 7/8" O.D. (.063 WIRE - 7 TURNS)
CLU9-0116N	5	VANE, DOOR CLOSE LWZ-2	CLU9-XXXXX	11	LINK, STANDARD CLUTCH
CLU9-0113N	5A	ROLLER, 1 1/4" DIA LWZ-2/LZ-2 CLUTCH	CLU9-XXXXX	12	LINK, LOW & LRC CLUTCH

# DOOR CLOSERS & RELATED PARTS

PART ID	PART DESCRIPTION
CL5-0001L	CLOSER, SS 22-27 DO & CP 24-55 DO SPRING
CL5-0001R	CLOSER, SS 22-27 DO & CP 24-55 DO SPRING
CL5-0002L	CLOSER, SS 28-35 DO & CP 56-71 DO SPRING
CL5-0002R	CLOSER, SS 28-35 DO & CP 56-71 DO SPRING
CL5-0003L	CLOSER, SS 36-40 DO CP 72-81 DO SPRING
CL5-0003R	CLOSER, SS 36-40 DO CP 72-81 DO SPRING
CL5-0004L	CLOSER, SS 41-44 DO & CP 82-89 DO SPRING
CL5-0004R	CLOSER, SS 41-44 DO & CP 82-89 DO SPRING
CL5-0005L	CLOSER, SS 45-48 DO & CP 90-97 DO SPRING
CL5-0005R	CLOSER, SS 45-48 DO & CP 90-97 DO SPRING
CL5-0011L	CLOSER, 2S 28-35 DO & 2CP 56-70 DO SPRING
CL5-0011R	CLOSER, 2S 28-35 DO & 2CP 56-70 DO SPRING
CL5-0012L	CLOSER, 2S 36-40 DO & 2CP 71-82 DO SPRING
CL5-0012R	CLOSER, 2S 36-40 DO & 2CP 71-82 DO SPRING
CL5-0013L	CLOSER, 2S 41-44 DO & 2CP 83-90 DO SPRING
CL5-0013R	CLOSER, 2S 41-44 DO & 2CP 83-90 DO SPRING
CL5-0014L	CLOSER, 2S 45-48 DO & 2CP 91-98 DO SPRING
CL5-0014R	CLOSER, 2S 45-48 DO & 2CP 91-98 DO SPRING
CL5-0051N	SPRING ROD ASSEMBLY
CL5-0259N	PLATE, CLOSER REINFORCEMENT W/STUDS
CL6-0001N	CLOSER, REEL ASSEMBLY



CL5-0259N



CL6-0001N



CL5-0004L

# DOOR EQUIPMENT HATCH HANGER SSSS DRAWING

**SINGLE SPEED - TYPE "A"  
22"- 48" DOOR OPENING**

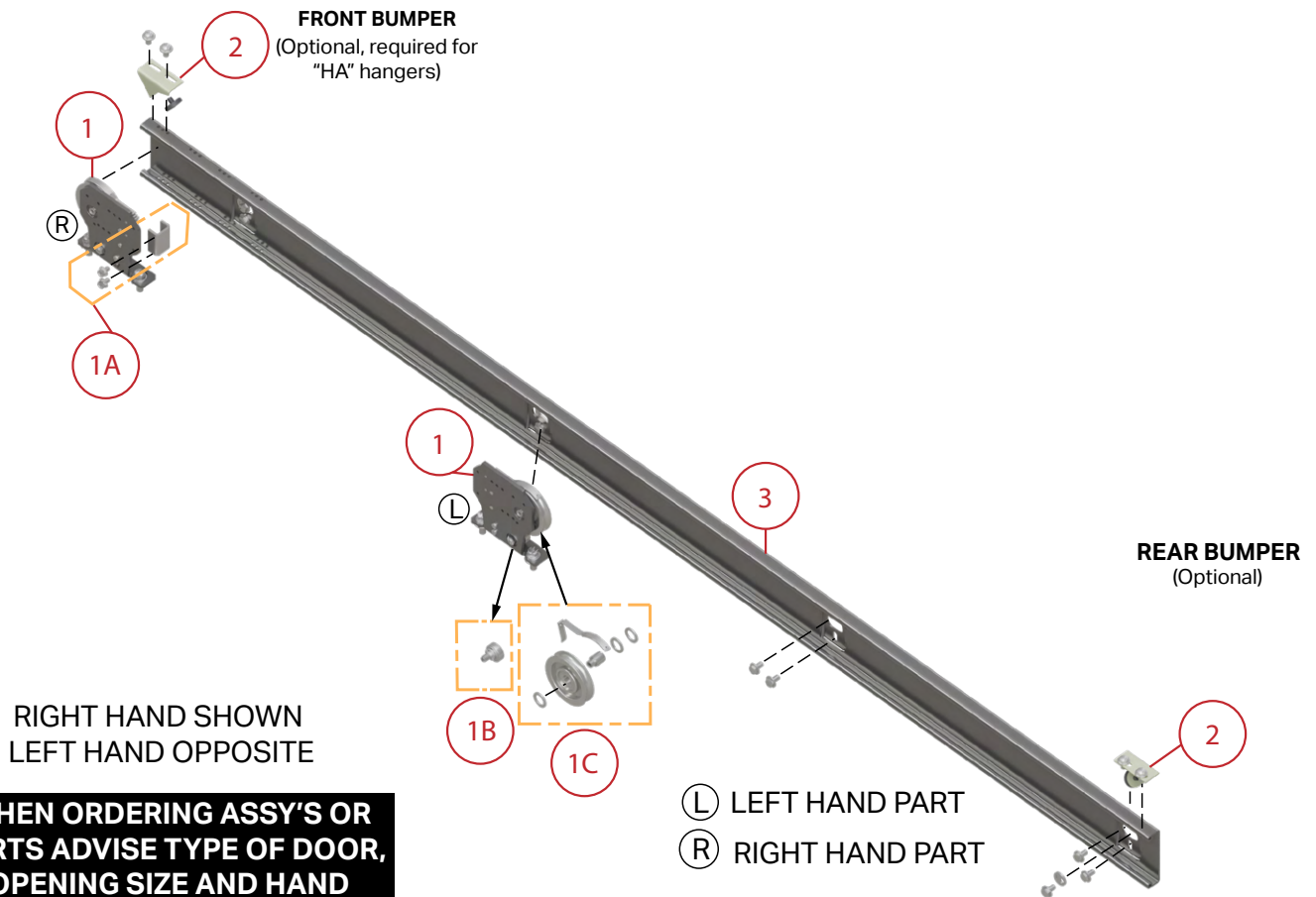

*\*Illustrations are for informational purposes only. Part #'s may have been changed or discontinued. Please reach out to your local representative for more information.*

PART NO.	ITEM NO.	PART DESCRIPTION
HH1-0105L/R	1	SHEAVE, 4-1/8 CL WITH 3/8-16 BOLTS TOP SAFETY RETAINER
HH1-0112N	1A	RETAINER, HANGER TOP SAFETY
HH1-0024N	1B	ECCENTRIC, "A" SHEAVE

PART NO.	ITEM NO.	PART DESCRIPTION
HH1-0025N	1C	ROLLER KIT, 3 1/4" DIA 'A'
HH4-0055N	2	BUMPER, "A" CP STOP
HH1-XXXX	3	TRACK, S/S HATCH DOOR

PART ID	PART DESCRIPTION
HH1-0099N	HANGER, A-SS 31"-33" D.O. HATCH
HH1-0100N	HANGER, A-SS 34"-36" D.O. HATCH
HH1-0101N	HANGER, A-SS 37"-39" D.O. HATCH
HH1-0102N	HANGER, A-SS 40"-42" D.O. HATCH
HH1-0103N	HANGER, A-SS 43"-45" D.O. HATCH
HH1-0017N	TRACK, A-SS 40"-42" D.O. HATCH-82"LG
HH1-0020N	HARDWARE BAG, SS-CP TRACK
HH1-0021N	ECCENTRIC & SCREW, TRACK
HH1-0023N	HARDWARE, "A" SHEAVE 3/8" BOLTS
HH1-0024N	ASSEMBLY, ECCENTRIC,"A" SHEAVE
HH1-0025N	ROLLER KIT, 3 1/4" DIA "A"
HH1-0027N	SHIM, 1/32 "A" SHEAVE 3/8" BOLTS
HH1-0029N	HARDWARE, "A" SHEAVE 1/2" BOLTS
HH1-0030N	SHIM, 1/32 "A" SHEAVE 1/2" BOLTS
HH1-0031N	SHIM, 1/8 "A" SHEAVE 3/8" BOLTS
HH1-0032N	TRACK SPACER, 11 GAUGE
HH1-0105L	SHEAVE, 4.125 CL 3/8-16
HH1-0105R	SHEAVE, 4.125 CL 3/8-16
HH1-0108L	SHEAVE, 4.250 CL 1/2-13
HH1-0108R	SHEAVE, 4.250 CL 1/2-13
HH1-0112N	RETAINER, TYPE "A" HANGER TOP SAFETY
HH1-0113N	SPACER, 4 1/8" CL. 3/8-16 BLT SHEAVE 1/8"
HH1-0115L	SHEAVE, 4.125 CL 1/2-13
HH1-0115R	SHEAVE, 4.125 CL 1/2-13
HH1-0151N	SPACER, SHEAVE 3/8" THICK
HH1-0183N	OILER/CLEANER 16 PACK, TYPE A
HH2-0052L	BRACKET, TRACK END 1 1/2"
HH2-0052R	BRACKET, TRACK END 1 1/2"
HH2-0163R	HANGER, A-2SP 43"-44" D.O. UNGEARED HATCH
HH10-0041N	ROLLER KIT, 2-1/4 DIA TYPE "OS"
HH17-0014N	BRACKET, WESTINGHOUSE III SHEAVE MOUNTING
HH19-0041N	HARDWARE, S/S-C/P WATER RESISTANT TRACK



HH1-0017N



HH1-0017N



HH1-0023N



HH1-0032N



HH1-0105L



HH1-0113N



HH1-0151N



HH1-0183N



HH10-0041N



HH17-0014N

# DOOR EQUIPMENT HANGER PARTS

## HATCH HANGER SHEAVE ASSEMBLIES TYPE "A" CONVENTIONAL SHEAVES CHART

**- HATCH DOORS -**

(SHEAVES INCLUDE SAFETY RETAINERS)

<b>S/SP</b> 24-48 D.O.				DAYLITE →			
		HH1-0105R	HH1-0105L				
<b>2/SP</b> 24-72 D.O.	24-72 D.O. STANDARD JOBS						
		HH1-0105R	HH1-0105L	HH1-0105R	HH1-0105L		
		SLOW DOOR SET		FAST DOOR SET			
<b>2/SP</b> 24-72 D.O.	30-48 D.O. GLASS JOBS ONLY (GEARED HANGER)						
		HH2-0208R	HH2-0208L	HH2-0206R	HH1-0105L		
		SLOW DOOR SET		FAST DOOR SET			
<b>3/SP</b> 30-69 D.O.	30-40 D.O.						
		HH1-0105R	HH1-0105L	HH1-0105R	HH1-0105L	HH9-0161R	HH1-0105L
		SLOW DOOR SET		INTERMEDIATE DOOR SET		FAST DOOR SET	
<b>3/SP</b> 30-69 D.O.	41-69 D.O.						
		HH1-0105R	HH1-0105L	HH1-0105R	HH1-0105L	HH1-0105R	HH1-0105L
		SLOW DOOR SET		INTERMEDIATE DOOR SET		FAST DOOR SET	
<b>C/P</b> 30-83 D.O.	30-59 D.O.						
		HH1-0105R	HH3-0034I	HH3-0034R	HH1-0105L		
				← CENTER LINE OF OPENING			
<b>2SP/CP</b> 30-83 D.O.	60-83 D.O.						
		HH1-0105R	HH1-0105L	HH1-0105R	HH1-0105L		
		HH1-0105R	HH1-0105L	HH1-0105R	HH1-0105L	HH1-0105R	HH1-0105L
		SLOW DOOR SET		FAST DOOR SET		FAST DOOR SET	
						SLOW DOOR SET	

SIDE SLIDE DOORS { LEFT HAND SHOWN  
RIGHT HAND OPPOSITE

NOTE:  
PART NUMBERS ARE FOR COMPLETE  
SHEAVE ASSEMBLIES.

PART ID	PART DESCRIPTION
HDW-0034N	GIBS, DOOR GUIDE NYLON
HH2-0206L	SHEAVE, 4.125 CL 3/8-16 2SP FAST
HH2-0206R	SHEAVE, 4.125 CL 3/8-16 2SP SLOW
HH2-0208L	SHEAVE, 4.125 CL 3/8-16 2SP SLOW
HH2-0208R	TRACK, A-CP 42"-44" D.O. 88"LG
HH3-0013N	CABLE, CP 36"-38" D.O. GEARING
HH3-0028N	CABLE, CP 51"-56" D.O. GEARING
HH3-0033N	HANGER, A-CP PULLEY 36-38 DO HATCH
HH3-0051N	HANGER, A-CP PULLEY 42-44 DO HATCH
HH3-0053N	HANGER, A-CP PULLEY 48-50 DO HATCH
HH3-0055N	CABLE, CP 57"-59" D.O. GEARING
HH3-0091N	SHEAVE, 4.125 CL 1/2-13 C/P HATCH
HH3-0121L	SHEAVE, 4.125 CL 1/2-13 C/P HATCH
HH3-0121R	OILER, TYPE "C" HANGER 3-1/4" ROLLER



*HDW-0034N*



*HH2-0206L*



*HH2-0208L*

# DOOR EQUIPMENT HATCH HANGER SSCP DRAWING

**CENTER PARTING (GEARED) - TYPE  
"A" 30"-59" DOOR OPENING**

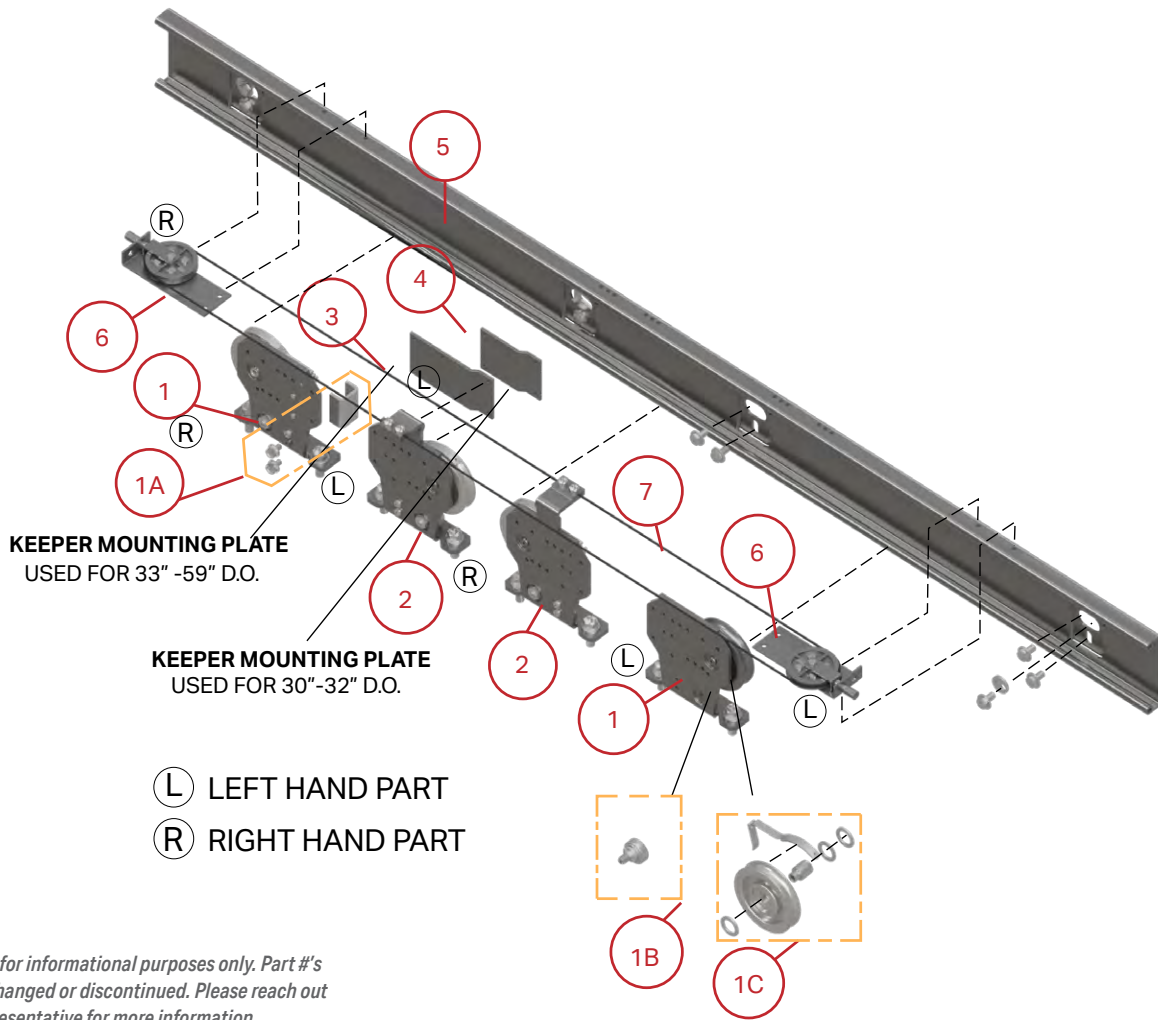

*\*Illustrations are for informational purposes only. Part #'s may have been changed or discontinued. Please reach out to your local representative for more information.*

PART NO.	ITEM NO.	PART DESCRIPTION
HH1-0105L/R	1	SHEAVE, 4-1/8 CL WITH 3/8-16 BOLTS AND TOP SAFETY RETAINER
HH1-0112N	1A	RETAINER, HANGER TOP SAFETY
HH1-0024N	1B	ECCENTRIC, "A" SHEAVE
HH1-0025N	1C	ROLLER KIT, 3 1/4" DIA "A"
HH3-0034L/R	2	SHEAVE, 4-1/8 CL WITH 3/8-16 BOLTS AND TOP SAFETY RETAINER

PART NO.	ITEM NO.	PART DESCRIPTION
INT1H-0038L/R	3	PLATE, MO KEEPER MOUNTING, 2/SP HA 37-72 D.O. C/P 33-59 D.O.
INT1H-0039N	4	PLATE, MO KEEPER MOUNTING, FOR C/P 30-32 D.O.
HH3-XXXX	5	TRACK, C/P HATCH DOOR
HH3-0042L/R	6	PULLEY ASSEMBLY, CP TENSION (REPLACEMENT)
HH3-XXXX	7	GEARING CABLE

# INTERLOCK ASSEMBLIES & RELATED PARTS

PART ID	PART DESCRIPTION
INT1H-0001L	INTERLOCK, MOH A LINK
INT1H-0001R	INTERLOCK, MOH A LINK
INT1H-0002L	INTERLOCK, MOH B LINK
INT1H-0002R	INTERLOCK, MOH B LINK
INT1H-0003L	INTERLOCK, MOH C LINK
INT1H-0003R	INTERLOCK, MOH C LINK
INT1H-0004L	INTERLOCK, MOH D LINK
INT1H-0004R	INTERLOCK, MOH D LINK
INT1H-0005L	INTERLOCK, MOH E LINK
INT1H-0005R	INTERLOCK, MOH E LINK
INT1H-0006L	INTERLOCK, MOH F LINK
INT1H-0006R	INTERLOCK, MOH F LINK
INT1H-0013L	SWITCH ASSEMBLY, MO INTERLOCK
INT1H-0013R	SWITCH ASSEMBLY, MO INTERLOCK
INT1H-0016L	KEEPER ASSEMBLY, MO INTERLOCK
INT1H-0016R	KEEPER ASSEMBLY, MO INTERLOCK
INT1H-0017N	CONTACT, MO KEEPER BRIDGING
INT1H-0019N	BUMPER, STEM MO INTERLOCK
INT1H-0022L	RELEASE ROLLER ASSY, MOH B LINK
INT1H-0022R	RELEASE ROLLER ASSY, MOH B LINK
INT1H-0023N	ROLLER & SHAFT, MO INTERLOCK, 2 3/8"
INT1H-0024L	CONTACT BASE, MO INTERLOCK
INT1H-0024R	CONTACT BASE, MO INTERLOCK
INT1H-0028N	LINK, LOWER "D" MO INTERLOCK ASSY-26 3/4"
INT1H-0034N	KEY, MO INTERLOCK EMERGENCY
INT1H-0035N	JUMPER, MO INTERLOCK ASSEMBLY
INT1H-0036L	CONTACT KIT, MO-MOCP-KT
INT1H-0036R	CONTACT KIT, MO
INT1H-0037N	PLATE, MO KEEPER MOUNTING
INT1H-0041N	ANGLE, SS-CP ESMO MOUNTING
INT1H-0043N	PLATE, MO KEEPER DOOR MOUNTED
INT1H-0076N	BRACKET, MO KEEPER MOUNTING SS-2SP
INT1H-0079R	INTERLOCK, MOH B LINK REL ROLLER CUT DOWN
INT1H-0097N	SPACER, 2 3/4" MO ROLLER RELEASE
INT1H-0197N	SPACER, 3/4" MO ROLLER RELEASE
INT1H-0215N	PLATE, INTERLOCK REINFORCEMENT W/STUDS
INT1H-0356L	BRACKET, MO INTERLOCK 2/SP
INT2H-0001N	INTERLOCK, MOCPH A LINK
INT2H-0002N	INTERLOCK, MOCPH B LINK
INT2H-0003N	INTERLOCK, MOCPH C LINK
INT2H-0004N	INTERLOCK, MOCPH D LINK



INT1H-0002L



INT1H-0016L

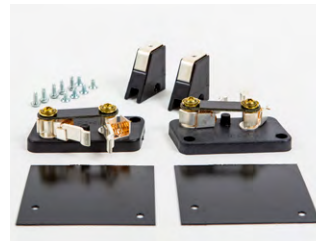

INT2H-0017N



INT1H-0022L



INT1H-0023N



INT1H-0024L



INT1H-0034N



INT1H-0036L



INT1H-0215N

PART ID	PART DESCRIPTION
INT2H-0005N	INTERLOCK, MOCPH E LINK
INT2H-0006N	INTERLOCK, MOCPH F LINK
INT2H-0015N	KEEPER FIXED, MOCP INTERLOCK
INT2H-0017N	CONTACT KIT, MOCP-KT COMPLETE
INT2H-0017R	CONTACT KIT, MOCP-KT
INT2H-0052N	PLATE, MOCP/MOH KEEPER MOUNTING CHANNEL, 2 3/16" MOCP/MOH LOCK MOUNTING
INT2H-0053N	PLATE, MOCPH/MOH KEEPER MTG-1/2" OFFSET
INT3-0010N	CONTACT, MOW/MOX BRIDGING
INT3W-0002L	INTERLOCK, MOWH B LINK
INT3W-0002R	INTERLOCK, MOWH B LINK
INT3W-0003L	INTERLOCK, MOWH C LINK
INT3W-0003R	INTERLOCK, MOWH C LINK
INT4-0001N	KEEPER, M/N INTERLOCK SWING DOOR
INT5-0015N	CONTACT KIT, M INTERLOCK LOWER
INT5-0016N	CONTACT BASE, M INTERLOCK UPPER
INT5-0017N	CONTACT BASE, M INTERLOCK LOWER
INT5-0018N	BRIDGING CONTACT, M/N/WP/WX/NHA UPPER
INT5-0019N	BRIDGING CONTACT, M/N SM/SN KEEPER
INT5-0024N	ARM & ROLLER, 3" CL
INT5-0025N	ARM & ROLLER, 4 1/2" CL
INT5-0030N	KEY, M/N INTERLOCK
INT5-0042N	JUMPER, M/N/MO INTERLOCK
INT7-0012N	KEEPER, DM INTERLOCK
INT8-0001N	LOCK/CONTACT, "SDM" 3" CL ROLLER ARM
INT8-0002N	SWITCH ASSEMBLY, SDM LOCK/CONTACT
INT22-0019N	CONTACT KIT, N/NHA INTERLOCK UPPER
INT22-0020N	CONTACT KIT, "N"/"SN" INTERLOCK LOWER



INT2H-0015N

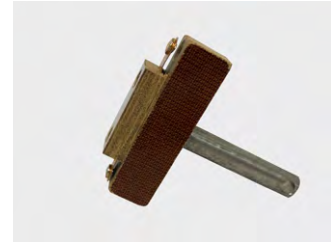

INT3-0010N

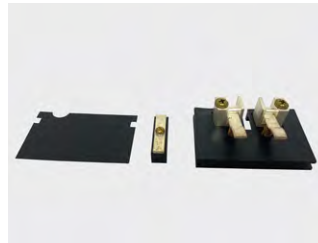

INT5-0015N

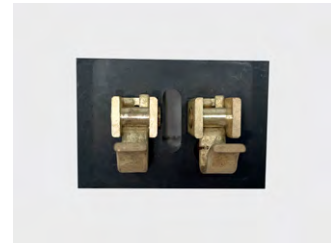

INT5-0016N



INT5-0019N



INT5-0024N



INT5-0030N

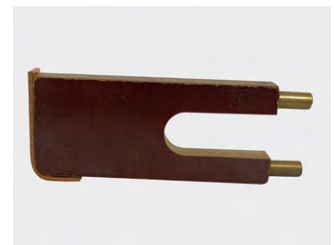

INT5-0042N



INT7-0012N

# GALAXY 4 CONTROLLER PARTS

## PRINTED CIRCUIT BOARDS (GALAXY 4)

### GALAXY IV

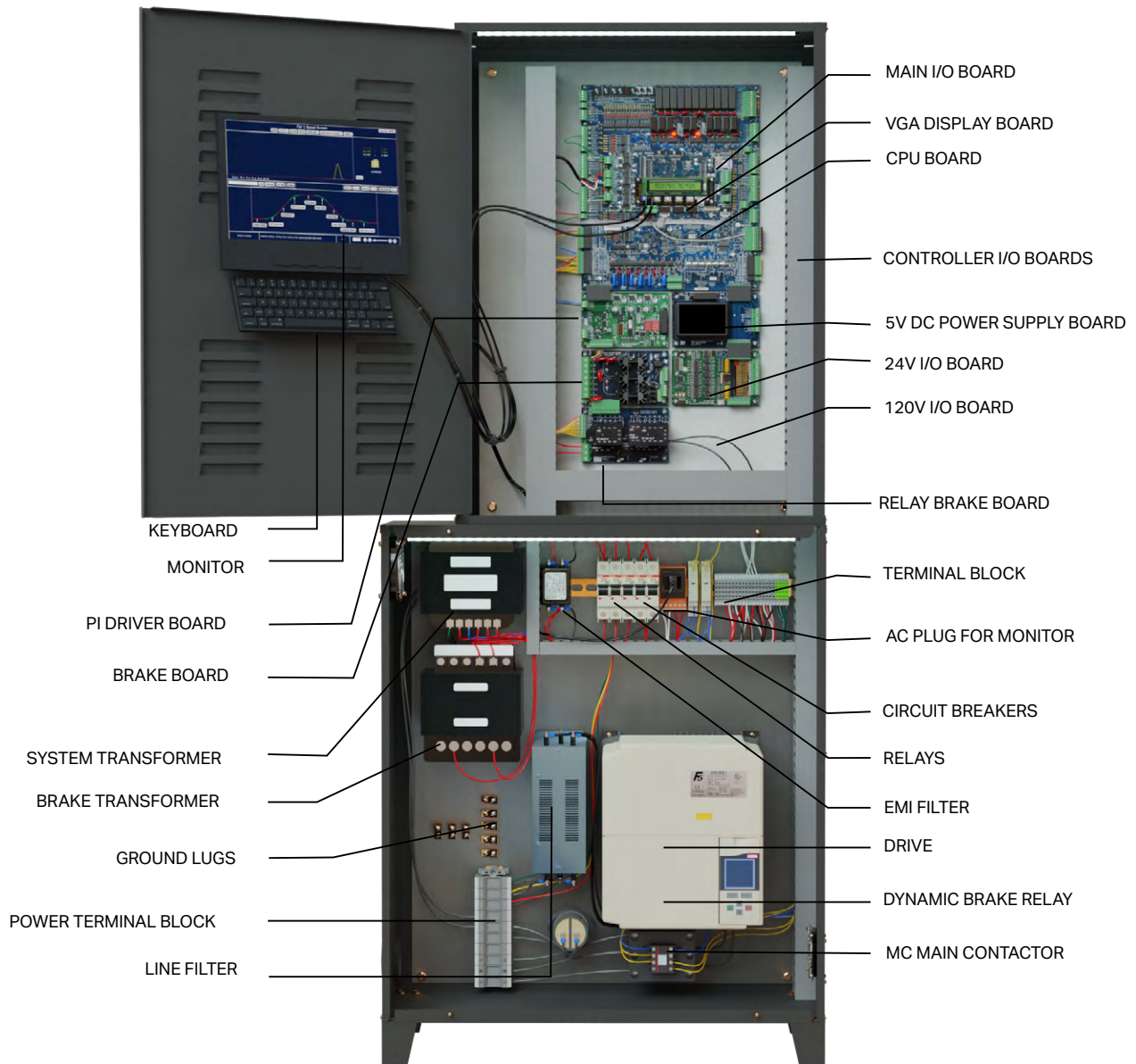

MAIN I/O BOARD

VGA DISPLAY BOARD

CPU BOARD

CONTROLLER I/O BOARDS

5V DC POWER SUPPLY BOARD

24V I/O BOARD

120V I/O BOARD

RELAY BRAKE BOARD

TERMINAL BLOCK

AC PLUG FOR MONITOR

CIRCUIT BREAKERS

RELAYS

EMI FILTER

DRIVE

DYNAMIC BRAKE RELAY

MC MAIN CONTACTOR

KEYBOARD

MONITOR

PI DRIVER BOARD

BRAKE BOARD

SYSTEM TRANSFORMER

BRAKE TRANSFORMER

GROUND LUGS

POWER TERMINAL BLOCK

LINE FILTER

PART ID	PART DESCRIPTION
GALX-0040N	SENSOR, NPN 10 TO 30VDC 150 MA
GALX-0058N	BOARD, CPU SIMPLEX HYDRO W/DL ROM DOS
GALX-1005AN	BOARD, LCD 4PB 26PIN RIBBON INTERFACE
GALX-1005BN	BOARD, LCD 4PB WITH WIFI INTERFACE
GALX-1021AN	BOARD, LCD DISPLAY
GALX-1023AN	BOARD, I/O 24VAC UNIVERSAL
GALX-1037AN	BOARD, LARGE CAR TOP
GALX-1038AN	BOARD, TRACTION MAIN I/O
GALX-1039AN	BOARD, HYDRO SIMPLE MAIN I/O
GALX-1039CN	BOARD, HYDRO S MAIN I/O CNTR STP
GALX-1040AN	BOARD, SMALL CAR TOP
GALX-1041AN	BOARD, UNIVERSAL I/O 120VAC
GALX-1042AN	BOARD, UNIVERSAL I/O COMPACT 120VAC
GALX-1043AN	BOARD, UNIVERSAL I/O COMPACT 24VAC
GALX-1057AN	BOARD, SERIAL HALL DRIVER
GALX-1057BN	BOARD, SERIAL HALL DRIVER GIV
GALX-1064AN	BOARD, TRACTION MAIN I/O REVISED
GALX-1066AN	BOARD, TRAC/HYDRO SPB SAFETY MONITOR
GALX-1070AN	BOARD, SERIAL HALL STATION - 24VDC
GALX-0170AN	BOARD, SERIAL HALL STATION
GALX-1100AN	BOARD, CPU FREESCALE TRACTION/HYDRO
GALX-1101AN	BOARD, DISPLAY VGA/LCD
GALX-1102AN	BOARD, TRACTION MAIN I/O GALX IV
GALX-1104AN	BOARD, 3PH BRAKE BOARD GALX IV

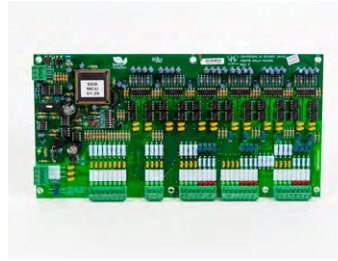

GALX-1023AN

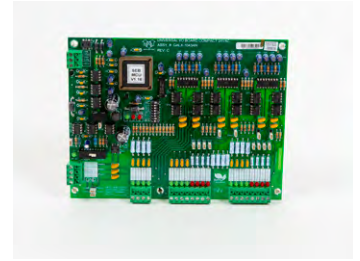

GALX-1043AN



GALX-1057AN

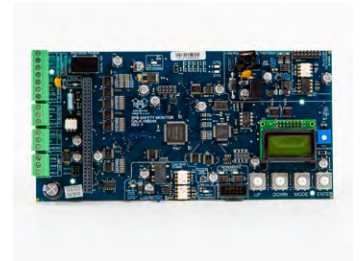

GALX-1066AN



GALX-1100AN



GALX-1101AN



GALX-1102AN



GALX-1104AN

PART ID	PART DESCRIPTION
GALX-1105AN	BOARD, BRAKE RELAY BOARD GALX IV
GALX-1105BN	BRK RELAY BOARD GALX IV, BRK-RUN, REV A
GALX-1106AN	BOARD, 120VAC I/O EXPANDER CNTRL
GALX-1107AN	BOARD, 24VAC/DC I/O EXPANDER CNTRL
GALX-1108AN	BOARD, 5V 6A POWER SUPPLY 120VAC IN
GALX-1109AN	BOARD, COP INTERFACE CE DRIVER
GALX-1110AN	BOARD, SELECTOR MAIN
GALX-1111AN	BOARD, I/O CONNECTOR, GALAXY IV
GALX-1114AN	BOARD, CAN BUS CE PI DRIVER
GALX-1116AN	BOARD, 5V 6A POWER SUPPLY 24VAC IN
GALX-1121AN	BOARD, GIV HYDRO MOTHERBOARD
GALX-1123AN	BOARD, I/O 24VDC
GALX-1133AN	CEDES SELECTOR INTERFACE BOARD
GALX-1134AN	BOARD, GIV HYDRO COP WITH CE DRIVER
GALX-1135AN	BOARD, GIV HYDRO POWER DISTRIBUTION
GALX-1137AN	BOARD, GIV CAN SERIAL HC BOARD
GALX4-0048N	GALAXY, HYDRO IO BOARD INPUT MODULE
GALX4-0049N	GALAXY, HYDRO IO BOARD OUTPUT MODULE



*GALX-1105AN*

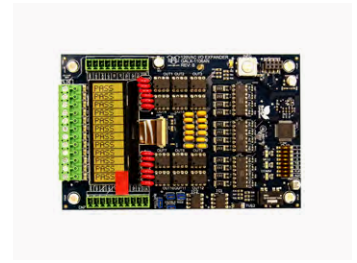

*GALX-1106AN*

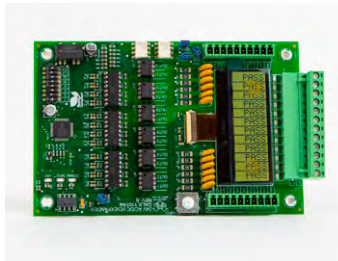

*GALX-1107AN*



*GALX-1108AN*



*GALX-1109AN*



*GALX-1110AN*



*GALX-1111AN*



*GALX-1114AN*

# ELECTRONIC DOOR EDGES & RELATED PARTS

PART ID	PART DESCRIPTION
DPFS-0002N	EDGE KIT, FORMULA SYSTEMS, FCU 47, MOVFR
DPFS-0003N	EDGE KIT, FORMULA SYSTEMS, FCU 47, W/ PWR SUPPLY
DPFS-0022N	EDGE KIT, 3D, FS VISION PLUS, 2019
DPFS-0023N	EDGE KIT, 3D, FS VISION PLUS, W/PWR SP, 2019
DPPC-0001N	CHIP, DOOR PROTECTION ENABLING
DPPC-0009N	POWER SUPPLY, LIGHT CURTAIN UNIVERSAL
DPSG-0001N	EDGE KIT, SCANGUARD II
DPSG-0002N	EDGE KIT, SCANGUARD II, WITH EXT PS
DPSG-0007N	CABLE SET, SCANGUARD II - 13' EXTENSION
DPTT-0007N	EDGE KIT, TRI-TRONICS WATER RESISTANT



DPPC-0001N



DPSG-0007N



DPSG-0001N

# MOVFR II TRAINING STAND

PART ID	PART DESCRIPTION
TRS1-0002N	OPER, MOVFR TRAINING STAND



TRS1-0002N

# KEYS & KEYSWITCHES

PART ID	PART DESCRIPTION
KEY-0066N	KEY, MEDECO "MK" CODE
KEY-0067N	KEY, GAL "1601" CODE
KEY-0068N	KEY, GAL "1612" CODE
KEY-0069N	KEY, GAL "1613" CODE
KEY-0070N	KEY, GAL "1617" CODE, PAINTED RED.
KEY-0072N	KEY, YALE "2642" CODE
KEY-0107N	KEY, ACE "FEO-K1" CODE (FIRE SERVICE)
KEY-0109N	KEY, GAL "1615P" CODE
KEY-0115N	KEY, GAL "1618" CODE
KS1-0093H	KEY SWITCH, RKB "BLANK" SPG RETURN 2P-R1
KS1-0093V	KEY SWITCH, RKB "BLANK" SPG RETURN 2P-R1
KS1-0096V	KEY SWITCH, RKB "OFF-UP-DN ACCESS" 3P-R1
KS1-0101H	KEY SWITCH, RKB "OFF-ON" 2P-R2 1NO-1NC
KS1-0101V	KEY SWITCH, RKB "OFF-ON" 2P-R2 1NO-1NC
KS1-0108V	KEY SWITCH, RKB "OFF-LIGHT-FAN" 3P-R3
KS1-0112H	KEY SWITCH, RKB "OFF-ON-IND. SERV." 2P-R2
KS1-0141H	KEY SWITCH, RKB "RUN-STOP" 1NO-1NC 2P-R2
KS1-0141V	KEY SWITCH, RKB "RUN-STOP" 1NO-1NC 2P-R2
KS3-0001H	KEY SWITCH, RKR ANSI-1996 FIRE SERVICE
KS3-0001V	KEY SWITCH, RKR ANSI-1996 FIRE SERVICE
KS3-0057H	KEY SWITCH, RKR ANSI-1996 FIRE SERVICE
KS3-0057V	KEY SWITCH, RKR ANSI-1996 FIRE SERVICE
KS3-0058H	KEY SWITCH, SKR ANSI-1996 FIRE SERVICE
KS3-0058V	KEY SWITCH, SKR ANSI-1996 FIRE SERVICE
KS3-0059H	KEY SWITCH, RKR ANSI CAR 3P-R3
KS3-0059V	KEY SWITCH, RKR ANSI CAR 3P-R3
KS3-0087H	KEY SWITCH, RKR ASME-2000 FIRE RECALL
KS3-0087V	KEY SWITCH, RKR ASME-2000 FIRE RECALL
KS3-0088H	KEY SWITCH, RKR ASME-2000 FIRE OPERATION
KS3-0088V	KEY SWITCH, RKR ASME-2000 FIRE OPERATION
KS3-0097H	KEY SWITCH, RKR EMERGENCY POWER 3P-R3
KS3-0097V	KEY SWITCH, RKR EMERGENCY POWER 3P-R3
KS3-0112H	KEY SWITCH, SKR ASME-2000 ME/NH CAR
KS3-0112V	KEY SWITCH, SKR ASME-2000 ME/NH CAR



KEY-0066N

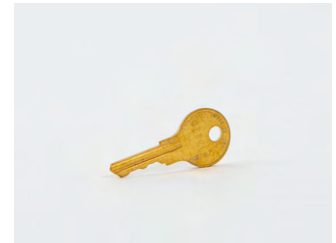

KEY-0067N



KEY-0068N



KEY-0069N

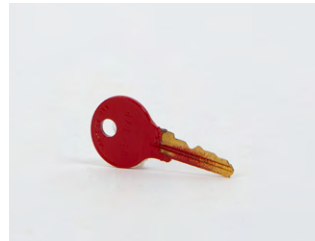

KEY-0070N



KEY-0072N



KEY-0107N



KS3-0057V



KS3-0088H



KS1-0141H

# ARGUS

The Argus Door Lock Monitor is a compact, out-of-the-box device that brings any elevator system into compliance with ASME 17.3 Section 3.10.12 (Door Fault Monitoring). Unlike competing devices, the Argus Door Lock Monitor allows door contact circuit monitoring to be accomplished via a built-in graphical user interface that does not require hardware configuration. Thanks to its innovative and patented design, this device will not fail if an input is mistakenly configured, as each input safely handles a rated voltage of up to 300V AC or DC, regardless of its configuration.



## EASIEST INSTALLATION. SHORTEST TIME TO COMPLIANCE.

- **Fits anywhere:** Installs inside existing elevator controller or externally, in a dedicated small (7"x7"x4") UL-listed enclosure.
- **Easy wiring verification:** Give instantaneous visual indication of status of each signal for easy identification and correction of wiring and configuration problems.
- **Future proof:** Firmware-based. When regulations change, bring device into compliance with seamless software upgrades using a PC and serial cable.
- **Energy efficient:** Consumes less than three watts, the same amount of power as a single relay (out of many) used by competing solutions.



FM3-0001N

PART ID	PART DESCRIPTION
FM3-0001N	ARGUS DOOR LOCK MONITOR
FM3-0002N	ARGUS DLM ENGINEERING PRINTS
FM3-0003N	ARGUS DLM OPTIONAL ENCLOSURE
FM3-0004N	ARGUS DLM OPTIONAL SENSOR KIT

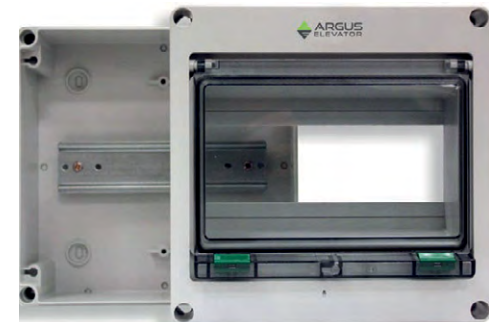

FM3-0003N

# PUSHBUTTONS & RELATED PARTS

PART ID	PART DESCRIPTION
PB2-1352N	PUSH BUTTON, VPW "BLANK" 2NO-48V
PB9-0001N	PB, RAS1 SS CONVEX 2NO STD & CA
PB9-0002N	PB, RAS2 SS CONCAVE 2NO STD & CA
PB9-0041N	PB, RAS1 SS CONVEX 1NO-1NC STD & CA
PB9-0042N	PB, RAS2 SS CONCAVE 1NO-1NC STD & CA
PBLB-0006AN	BOARD, LED UNIVERSAL, STANDARD

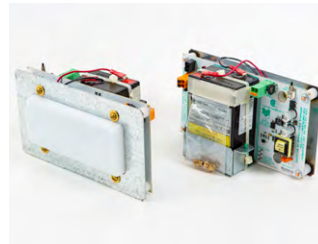

EMER-0069N



BAT-0003N

# EMERGENCY LIGHT

PART ID	PART DESCRIPTION
EMER-0069N	ASSEMBLY, EMERGENCY LIGHT NON-FLUSH LENS
BAT-0003N	BATTERY, SEALED LEAD ACID



CTI-0001N

# INSPECTION STATION

PART ID	PART DESCRIPTION
CTI-0001N	INSPECTION STATION, CT-10 CAR TOP



# HOLLISTER WHITNEY PARTS

# GOVERNOR AND GOVERNOR PARTS

## OVERSPEED GOVERNORS

Overspeed Governor with either standard or live shaft is designed and built to meet both the ASME A17.1 code and G.S.A. specifications. Governor is tested, preset, and sealed at the factory and comes standard with an overspeed switch, rope guard, and right or left hand arrangement.

**Options** (available at an additional charge):

- Dusttight, watertight, and explosion proof switches
- Speed reducing switch
- Bracket hardware for adapting an encoder



Model 208 (Left Hand Shown)

	OVERSPEED GOVERNOR MODELS			
	201 & 202	207	208	210
CAR SPEED FPM (MAX.)	500		800	
TRIP SPEED FPM	625		970	
SHEAVE DIAMETER	16"	12"	16"	
OVERSPEED SWITCH	Std.			
SPEED REDUCING SWITCH	Optional			
ROPE TYPE AND SIZE	1/2" or 3/8" 8x19 T.S.	3/8" 8x19 T.S.	1/2" or 3/8" 8x19 T.S	
HAND	Right or Left			
MAX. PULL THRU	1200 lbs			
MIN. PULL THRU	300 lbs			
SHIPPING WEIGHT	180 lbs			

DEAD SHAFT MODELS		
201	207	208
201-SW	207-SW	208-SW
	207-RS	
LIVE SHAFT MODELS (FOR ENCODER MOUNTS)		
202-0.25	207-0.25	210-0.25
202-0.25-SW	207-0.25-SW	210-0.25-SW
202-0.472	207-0.472	210-0.472
202-0.472-SW	207-0.472-SW	210-0.472-SW
202-0.75-SW	207-0.472-RS	210-0.75
202-1.00	207-0.75	210-0.75-SW
202-1.00-SW	207-0.75-SW	210-1.00
	207-0.75-RS	210-1.00-SW
	207-1.00	
	207-1.00-SW	
	207-1.00-RS	
<b>SW</b> - Speed Reducing Switch		
<b>RS</b> - Remote Set and Reset Capabilities		

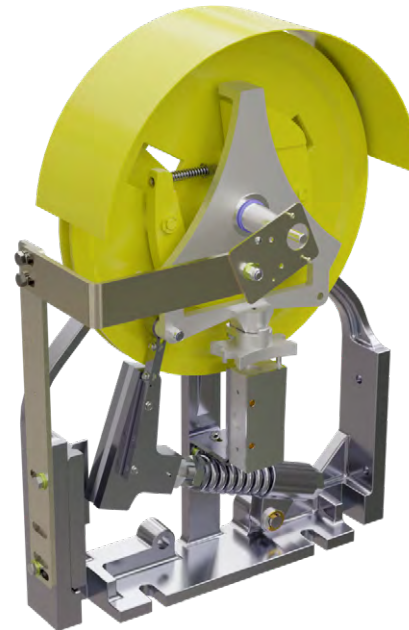

Model 210 (Left Hand Shown)

**DIMENSIONS (INCHES)**

**LEFT HAND MODELS SHOWN**

*Models 201 & 202*

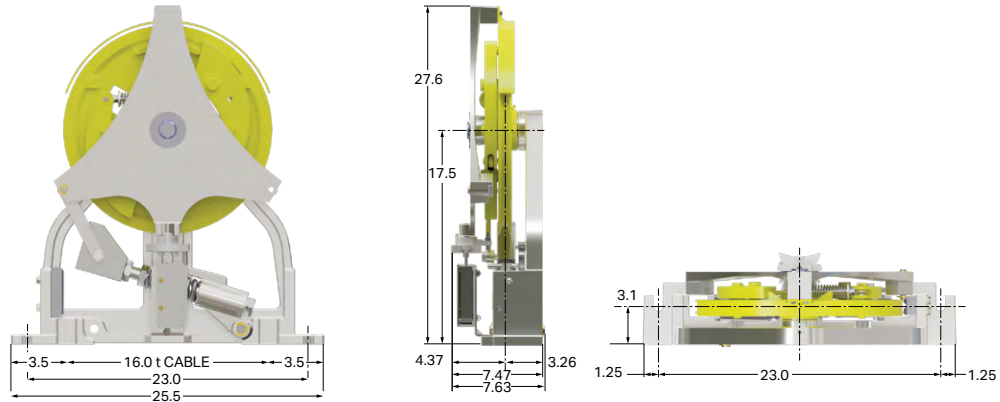

*Model 207*

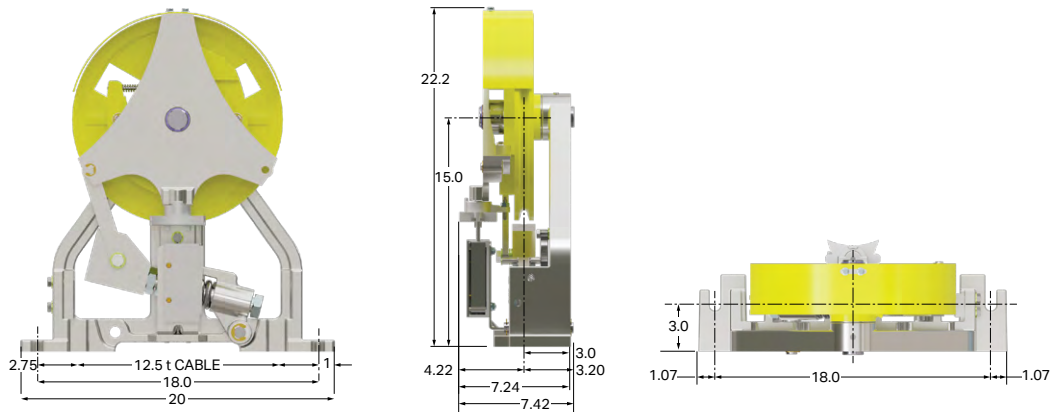

*Models 208 & 210*

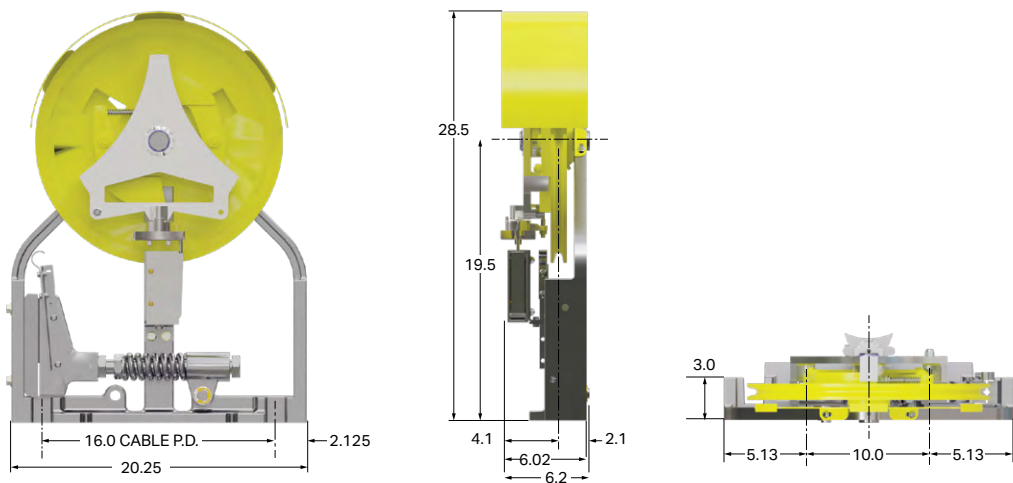

# REMOTE TRIP & RESET GOVERNORS

## 207 - RS STANDARD & LIVE SHAFT GOVERNORS

### Governor Remote Reset

After the elevator has experienced an overspeed condition in which the governor tripped and set the safety, it will be necessary to reset the systems after the elevator has been deemed safe for operation.

1. To reset the governor hammer, run the car in the up direction. By moving the car up, it will release the tension on the governor rope, and the hammer can be returned to the ready-to-run position.
2. Once the hammer has been reset, it is necessary to reset the overspeed switch. Provided in the controller is an optional feature that will energize an electric actuator that will reset the overspeed switch to the ready-to-run position.

### Governor Remote Trip

In a Machine-Room-Less application, if it is necessary to have a method to manually trip the governor for test and inspection purposes, the controller should provide a feature that will activate the speed trip test. For safety purposes, it is recommended that the test first be performed at a slow speed. To perform the test, run the car in the down direction, then activate the feature. This will trigger an actuator on the governor, which in turn will cause the governor to activate and set the safety. Follow the Governor Remote Reset Instructions to return the car to the ready-to-run state.

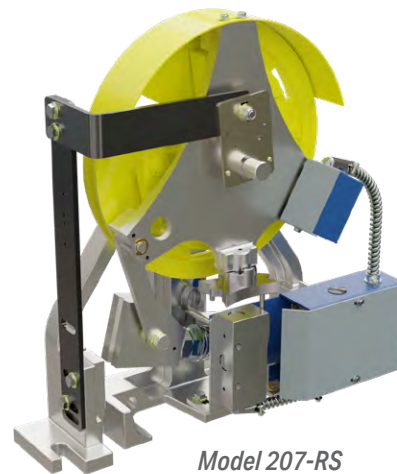

Model 207-RS  
(Left Hand model Shown)

## DIMENSIONS (INCHES)

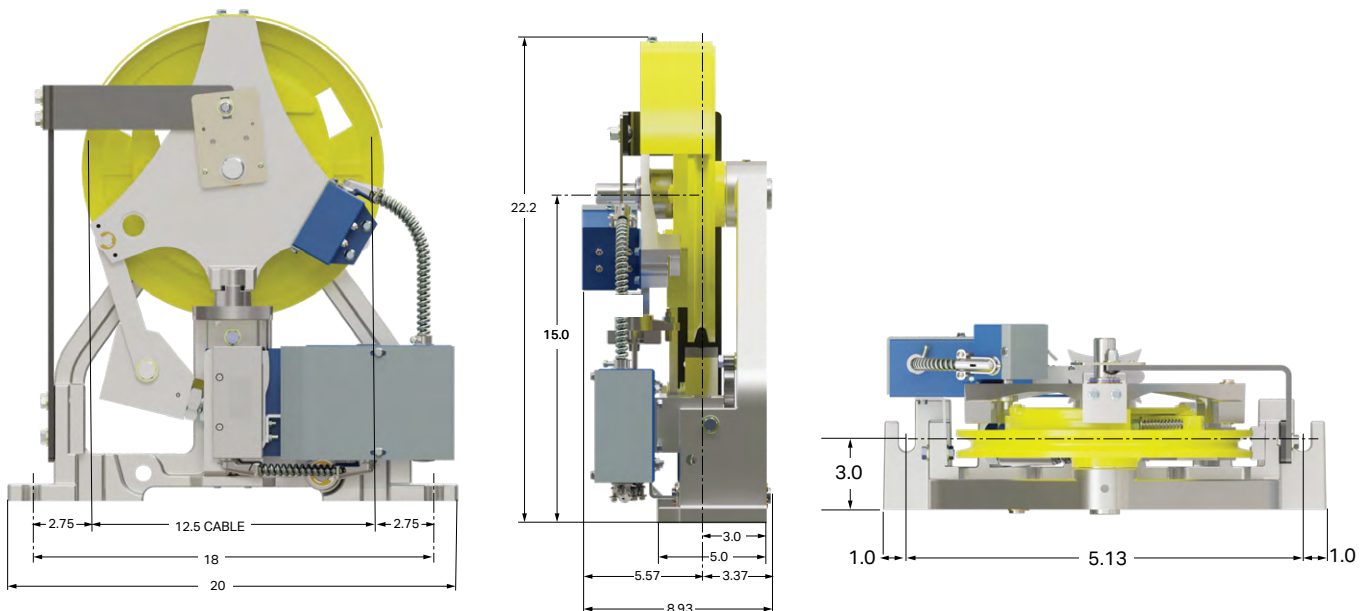

PART ID	PART DESCRIPTION
HW-201-005	HEAD 3/8"
HW-201-006	HEAD 1/2"
HW-201-012	GRIP 3/8"
HW-201-013	GRIP 1/2"
HW-201-023	OVERSPEED SWITCH
HW-201-100	GOVERNOR ENCLOSURE / GUARD
HW-201-LH	16" GOVERNOR ASSEMBLY LH
HW-201-RH	16" GOVERNOR ASSEMBLY RH
HW-201MK-000	GOVERNOR MOUNTING PLATE KIT 201 & 202
HW-201SK-210	SPRING ASSY 201/2 GOV, 175-210 TRIP
HW-201SK-280	SPRING ASSY 201/2 GOV, 211-280 TRIP
HW-201SK-410	SPRING ASSY 201/2 GOV, 281-410 TRIP
HW-201SK-624	SPRING ASSY 201/2 GOV, 411-624 TRIP
HW-201SK-625	SPRING ASSY 201/2 GOV, 625 TRIP
HW-202-0.472-LH	LIVE SHAFT GOVERNOR 12MM:CAR GOVERNOR
HW-202-0.472-RH	LIVE SHAFT GOVERNOR 12MM:CAR GOVERNOR
HW-205-012	GRIP 3/8"
HW-205SK-225	SPRING ASSY 205/6/7 GOV, 175-225 TRIP
HW-205SK-308	SPRING ASSY 205/6/7 GOV, 226-308 TRIP
HW-205SK-395	SPRING ASSY 205/6/7 GOV, 309-395 TRIP
HW-205SK-625	SPRING ASSY 205/6/7 GOV, 396-625 TRIP
HW-207-0.472-LH	GOVERNOR LIVE SHAFT 12MM LH
HW-207-0.472-RH	GOVERNOR LIVE SHAFT 12MM RH
HW-207-005	HAMMER HEAD 3/8"
HW-207-100	GOVERNOR ENCLOSURE / GUARD
HW-207-LH	12" GOVERNOR ASSEMBLY LH
HW-207-RH	12" GOVERNOR ASSEMBLY RH
HW-207-RS-LH	GOVERNOR ASSEMBLY - RESETTABLE LH
HW-207-RS-RH	GOVERNOR ASSEMBLY - RESETTABLE RH
HW-207MK-000	GOVERNOR MOUNTING PLATE KIT 207
HW-208-LH	GOVERNOR ASSEMBLY LH
HW-208-RH	GOVERNOR ASSEMBLY RH
HW-400-001	SPRING - GOV PULL THRU & EQUALIZER
HW-400-065	SPRING - #540 IS SAFETY GOVERNOR ROD
HW-400-068	SPRING - #480 FGC SAFETY GOVERNOR ROD
HW-540-019	RETAINER - SPRING 16 GA. 1 1/4"O.D.
HW-540-022	ANGLE - GOVERNOR ROD
HW-P-182	GOVERNOR DATA TAG(W/H-W NAME)
HW-P-182-1	GOVERNOR DATA TAG(W/O H-W NAME)
SEL-0093N	CAM ASSY KIT, "LS" LIMIT SWITCH, 10'-0"



HW-201-023



HW-201-100



HW-201SK-210



HW-205SK-308



HW-207-RH



HW-205SK-225



HW-400-068



HW-400-065

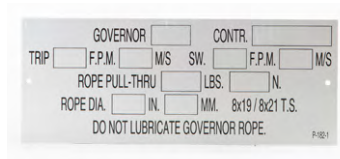

HW-P-182

# TENSION WEIGHTS

- #191 Swing Type - 12" Dia.
- #192 Swing Type - 16" Dia.
- #193 Frame Type - 16" Dia.
- #194 Frame Type - 12" Dia.

Shipping weight for Tension Weights approximately 160#

Adjustable Arms are available for some models

Guard also available

## DIMENSIONS (INCHES)

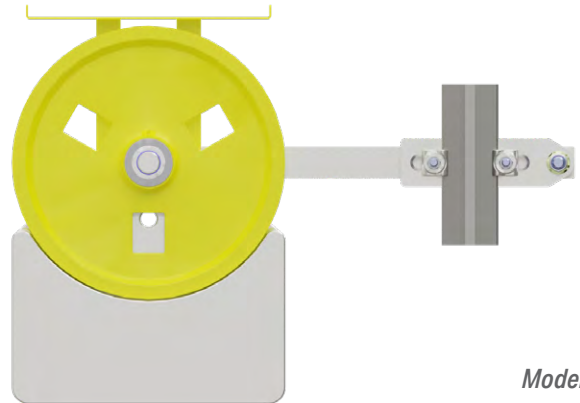
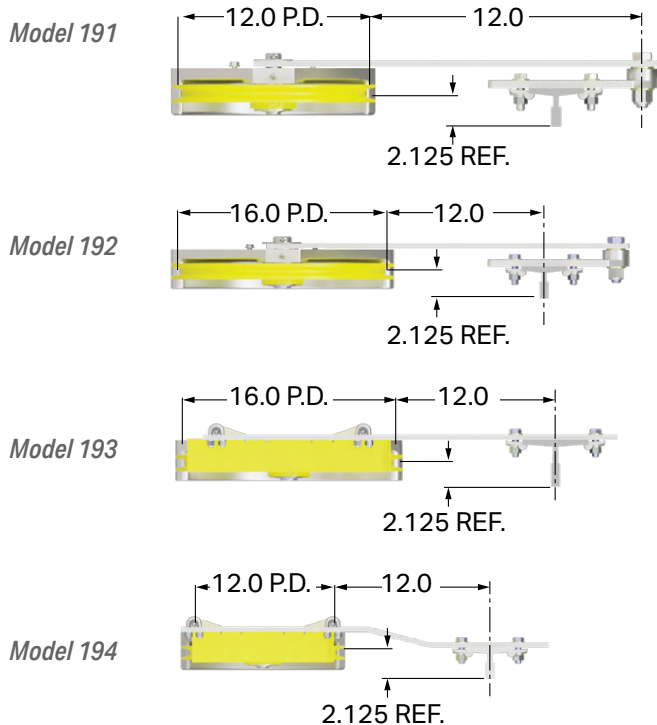

Model 192

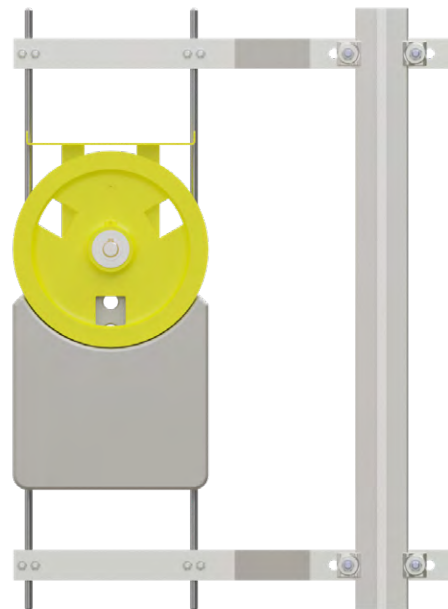

Model 194

## WHEN ORDERING, PLEASE SPECIFY THE FOLLOWING

### Governors

- Tripping Speed
- Right or Left Hand Arrangement
- Safety Pull-through (in-lbs.)
- Governor Rope Size

\*NOTE: Maximum car travel for #209 with 3/8" rope is 500'  
Maximum car travel for #209 with 1/2" rope is 300'

### Tension Weights

- Rail Size
- Governor Size

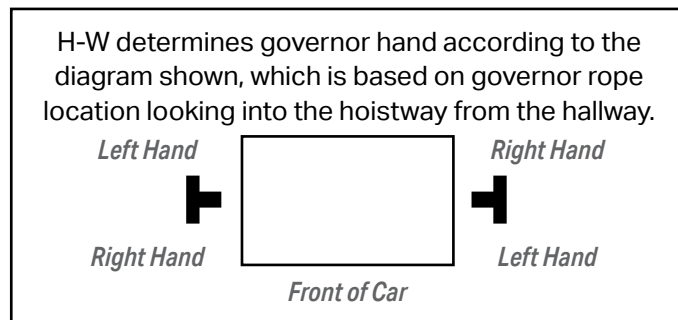

# ROPE GRIPPER AND GRIPPER PARTS

## STANDARD ROPE GRIPPER

In recent years, there has been a great deal of discussion about the need for protection against injuries caused by elevator cars leaving the floor with the doors open and overspeeding in the up direction. That's why Hollister-Whitney introduced the Rope Gripper, a remarkable device used to grab elevator suspension ropes to stop the elevator in the event of a mechanical or electrical failure. It is imperative if an elevator overspeeds in the up direction and/or if the elevator leaves the floor with doors open.

The Rope Gripper has many unique features, such as a gently applied but powerful 'grip' which doesn't damage the rope or cause any undue stress to the machine or traction sheave. Protection is assured even when slipping traction occurs. The Rope Gripper provides easy alignment with adequate clearances between the rope and self grooving 'grip' linings and provides power compensation with a constant but powerful force to the rope even as the linings wear. Only four wires are required to the elevator controls and installation is simple. The Rope Gripper is mechanically activated and hydraulically reset.



PUMPING UNIT

		ROPE GRIPPER MODEL				LINEAR ROPE GRIPPER MODEL	
		#620	#622	#624	#626	#620L	#622 L
1:1 ROPING	OUT-TO-OUT (MAX):	5 1/4" (124mm)	6 1/2" (152mm)	10" (254mm)	10" (254mm)	5 1/4" (133mm)	6 1/2" (165mm)
	POWER SUPPLY:	6A, 120V ac. 1PH, 60Hz				1A, 110 - 240VAC, 1 PH, 50/60Hz	
	CONTACT RATINGS:	6A, 250V ac. 0.15A, 250V ac				5A, 250VAC / 5A, 30VDC	
	RATED SPEED:	350 fpm (1.78 m/s)	600 fpm (3.05 m/s)		1,200 fpm (6.10 m/s)	300 fpm (1.78 m/s)	600 fpm (3.05 m/s)
	TRIPPING SPEED:	402 fpm (2.04 m/s)	690 fpm (3.51 m/s)		1,368 fpm (6.95 m/s)	402 fpm (2.04 m/s)	690 fpm (3.51 m/s)
	CAR RATED LOAD:*	2,500 lbs (1,134 kg)	5,000 lbs (2,268 kg)		10,000 lbs (4,536 kg)	2,560 lbs (1,161 kg)	5,000 lbs (2,268 kg)
	SYSTEM MASS:**	11,500 lbs (5,216 kg)	18,600 lbs (8,437 kg)		38,000 lbs (17,236 kg)	12,070 lbs (5,475 kg)	18,600 lbs (8,437 kg)
	DOOR ZONE:	10 inches (254mm) ±				3 inches (76.2mm) ±	
	CAR RATED LOAD:	600 lbs (272 kg)	1,500 lbs (680 kg)		2,500 lbs (1,134 kg)	600 lbs (272 kg)	1,500 lbs (680 kg)
	CAR & CTW MASS:	2,280 lbs (1,034 kg)	6,000 lbs (2,722 kg)		8,000 lbs (3,692 kg)	2,280 lbs (1,034 kg)	6,000 lbs (2,722 kg)
2:1 ROPING	RATED SPEED:	250 fpm (1.27 m/s)	400 fpm (2.03 m/s)		800fpm (4.06 m/s)	250 fpm (1.27 m/s)	400 fpm (2.33 m/s)
	TRIPPING SPEED:	303 fpm (1.54 m/s)	459 fpm (2.33 m/s)		921 fpm (4.68 m/s)	303 fpm (1.54 m/s)	459 fpm (1.54 m/s)
	CAR RATED LOAD:*	5,000 lbs (2,268 kg)	10,000 lbs (4,536 kg)		20,000 lbs (9,072 kg)	5,120 lbs (2,322 kg)	10,000 lbs (4,536 kg)
	SYSTEM MASS:**	23,000 lbs (10,432 kg)	38,000 lbs (17,236 kg)		76,000 lbs (34,472 kg)	24,140 lbs (10,950 kg)	38,000 lbs (17,237 kg)
	DOOR ZONE:	10 inches (254mm) ±				3 inches (76.2mm) ±	
	CAR RATED LOAD:	1,500 lbs (680 kg)	2,500 lbs (1,134 kg)		5,000 lbs (2,268 kg)	1,500 lbs (680 kg)	2,500 lbs (1,134 kg)
	CAR & CWT MASS:	6,000 lbs (2,722 kg)	8,000 lbs (3,629 kg)		16,000 lbs (7,258 kg)	6,000 lbs (2,722 kg)	8,000 lbs (3,629 kg)
	SHIPPING WEIGHT:	100 lbs (45 kg)	180 lbs (82 kg)	300 lbs (136 kg)	335 lbs (152 kg)	80 lbs (36 kg)	120 lbs (54 kg)

\* with 40 - 50% counterweight

\*\* includes car, car load, counterweight, hoist and compensation rope mass



Model 624



Model 622L

## STANDARD ROPE GRIPPER NOTES

- Model 624 Rope Gripper has one less spring and cylinder than Model 626 shown on next page
- Pumping units can be mounted on either side of Rope Gripper
- (4) 5/8" bolts (Grade 5 Minimum) are required to mount Rope Gripper and (4) 1/4" - 20 N.C. bolts to mount pumping unit
- C dimension indicates lining width and maximum outside to outside of hoist ropes
- L dimension is adjustable from 0° - 40° (Models 624 & 626); 0° - 45° (Models 620 & 622)
- R dimension is 5/8" + Rope Size

## LINEAR ROPE GRIPPER NOTES

- Compatible with spreads up to 5-1/4" (620L) or 6-1/2" (622L) (133 mm to 165 mm)
- Small, self-contained compact design
- Provides adequate clearances between the rope and self-grooving "grip" linings
- Eliminates the need for a hydraulic pump for installation in smaller areas
- Adjustable for rope size
- Only four wires are needed to connect the Rope Gripper to the controller

## WHEN ORDERING ROPE GRIPPER, SPECIFY THE FOLLOWING:

- |                        |  |  |
|------------------------|--|--|
| • Capacity             | • Rope Weight                          | • 1:1 or 2:1 Roping  |
| • Car Speed            | • Compensation Weight                  | • Single or Double Wrap  |
| • Empty Car Weight     | • Number and Size of Cables            | • 96" Standard Length of Hydraulic Hose (Other Lengths Available Upon Request) |
| • Counterweight Weight | • Center Line to Center Line of Cables |  |

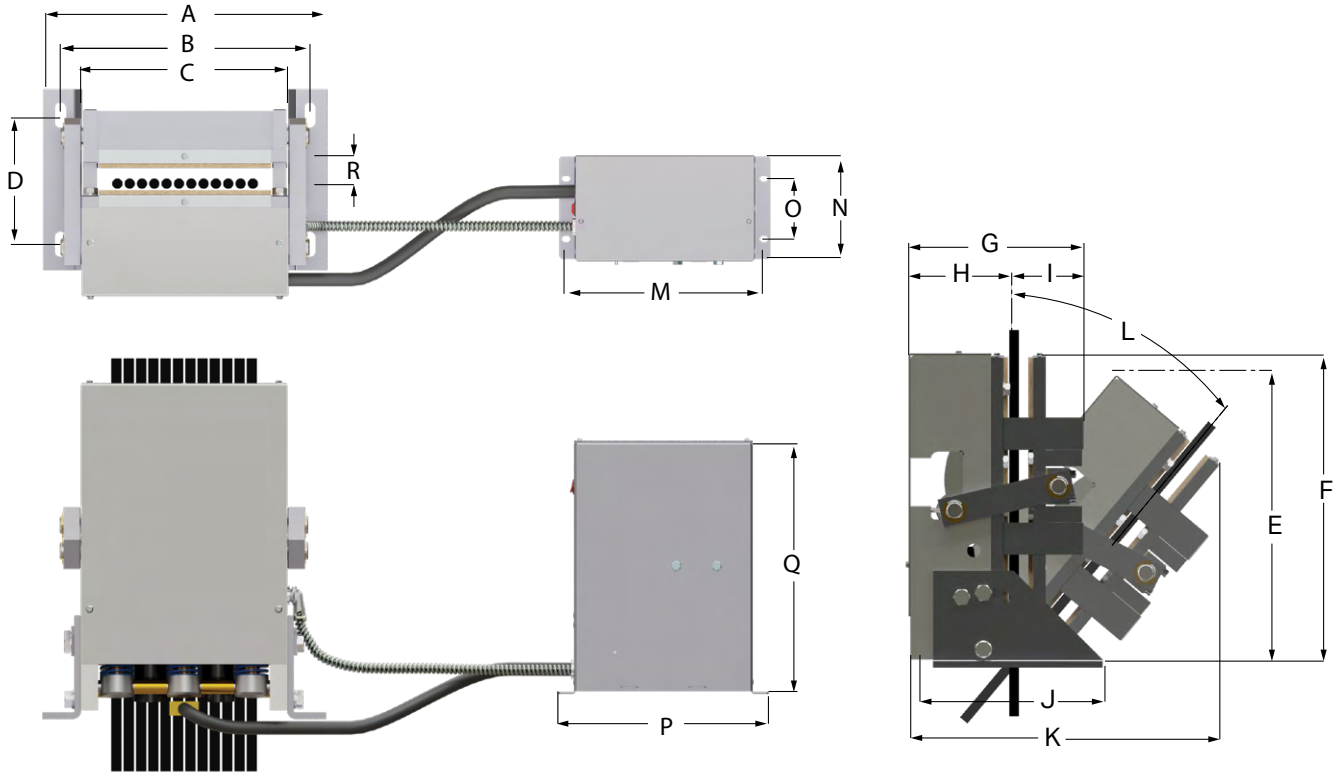

MODEL	UNIT	A	B	C	D	E	F	G	H	I	J	K	L	M	N	O	P	Q	R
620	INCH	10.125	8.625	4.875	5.5	11.6875	12	9.25	5.75	3.5	9.5	13.5	45°	11.5	6.4375	3.5	12.25	14.6875	1.25
	MM	257	219	124	140	297	305	235	146	89	241	343		292	163	89	311	373	32
622	INCH	11.5	10	6	5.5	14.6875	16.25	9	5.75	3.25	9.5	18.5	45°	11.5	6.125	3.5	12.25	14.6875	1.25
	MM	292	254	152	140	373	413	229	146	83	241	470		292	156	89	311	373	32
624	INCH	16.5	14.5	10	7.5	18.0625	19.625	10.75	6.375	4.375	12	18.5625	40°	11.5	6.4375	3.5	12.25	14.6875	1.94
	MM	419	368	254	191	459	498	273	162	111	3.5	471		292	163	89	311	373	49
626	INCH	16.5	14.5	10	7.5	18.0625	19.625	10.75	6.375	4.375	12	18.5625	40°	11.5	6.4375	3.5	12.25	14.6875	1.94
	MM	419	368	254	191	459	498	273	162	111	3.5	471		292	163	89	311	373	49
620L	INCH	10.125	8.625	5.25	5.5		15.625		8.625			13.5	45°						
	MM	257	219	133	138	408	397	319	219	94	317	343							
622L	INCH	11.4675	10	6.5	5.5	19.5938	19.0625	12.3125	8.5625	3.75	12.4062	15.9688	45°						
	MM	291	254	165	138	498	484	319	217	95	315	406							

PART ID	PART DESCRIPTION
HW-620-008	SPACER (PIVOT BLOCK) 1/8"
HW-620-008-1	SPACER (PIVOT BLOCK) 1/16"
HW-620-008-2	SPACER (PIVOT BLOCK) 1/32"
HW-622-022	LINING ASSEMBLY (6-1/2 X 10) 622 GRIPPER
HW-600-035	HYDRAULIC CYLINDER (994099) - 622/624
HW-600-041L	MOUNTING ANGLE - LEFT
HW-600-041R	MOUNTING ANGLE - RIGHT
HW-620-022	LINING ASSEMBLY (5-1/4 X 8) 620 GRIPPER
HW-601-035	HYDRAULIC CYLINDER (116861-5) - 620
HW-610-022	LINING ASSEMBLY (10 X 16) 624-626 GRIPPER
HW-610-035	HYDRAULIC CYLINDER (996043-015) - 626
HW-610-087	ELBOW - 90 DEGREE
HW-610-091	90 DEGREE STREET ELBOW
HW-620	ROPE GRIPPER ASY W/PUMPING UNIT&8FT HOSE
HW-620-037	HYDRAULIC HOSE - 27" STD.
HW-620-037-4	HYDRAULIC HOSE - 4' LG.
HW-620-037-6	HYDRAULIC HOSE - 6' LG.
HW-620-037-8	HYDRAULIC HOSE - 8' LG.
HW-620-038	VPARKER 6602-6-6 COUPLING
HW-620-041-45	MOUNT ANG, INSIDE 44F/45, 24-30" TW 620
HW-620-100A	620-626 PUMPING UNIT REPLACEMENT KIT
HW-620-116	REDUCER 3/8 MALE TO 1/4 FEMALE
HW-620-607	SOLENOID LOCKING UNIT (REPL RG-0003N)
HW-620L	ROPE GRIPPER ASSEMBLY - LINEAR
HW-622	ROPE GRIPPER ASY W/PUMPING UNIT&8FT HOSE
HW-622-040	COVER .090 ABS BLACK
HW-622-041-44	INVERTED MOUNTING ANGLE - PAIR
HW-622-064-1	SWITCH ASSY W/10' LEAD
HW-622L	ROPE GRIPPER ASSEMBLY - LINEAR
HW-624	ROPE GRIPPER ASY W/PUMPING UNIT&8FT HOSE
HW-624-041-64	INVERTED MOUNTING ANGLE - PAIR
HW-626	ROPE GRIPPER ASY W/PUMPING UNIT&8FT HOSE
HW-BZ-2RW824-A2	MICRO SWITCH
HW-CAP-0091N	RG PUMP CAPACITOR 145-174
HW-CAP-0131N	CAPACITOR, 124-148 250 VAC 50/60HZ
HW-SHC-524	FULL SYNTHETIC MOBIL 1 GRIPPER OIL 1GL



HW-622-022



HW-600-035



HW-600-041L



HW-620



HW-620-037-4



HW-620-100A



HW-622-041-44



HW-Cap-0131N

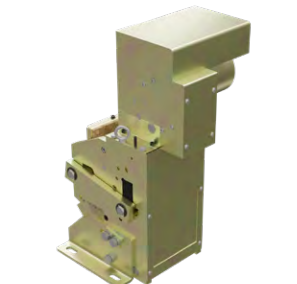

HW-620G

# BRAKE PARTS (GEARED MACHINE)

## DC DISC BRAKES

Hollister-Whitney's Direct Current Disc Brakes feature a completely enclosed coil, individual spring tension adjustment, and individual stroke adjustments. They are easy to install and adjust.

Operating voltage on Brake Coil is 230 Volts D.C. (115 Volts Optional). When using 230-volt coil, voltage may be decreased to 160 volts for running and holding. For 115-volt coil, voltage may be decreased to 85 volts for running and holding. A.C. to D.C. Rectifier Panels and Transformer available.

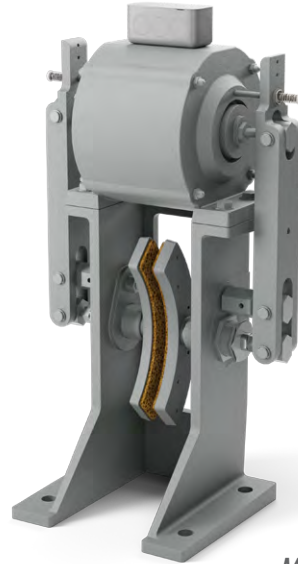

### ELECTRICAL INFORMATION

	MODEL 92 <i>(used on 34 machine)</i>			MODEL 102 <i>(used on 44 &amp; 54 machines)</i>			MODEL 112 <i>(used on 64 machine)</i>	
	Optional	Standard		Optional	Standard		Optional	Standard
	115V	230V		115V	230V		115V	230V
<b>Ohms</b>	33	138	<b>Ohms</b>	46.45	190	<b>Ohms</b>	46.45	190
<b>Amps</b>	3.48	1.66	<b>Amps</b>	2.44	1.24	<b>Amps</b>	2.44	1.24
<b>Watts</b>	400	380	<b>Watts</b>	277	292	<b>Watts</b>	277	292

### WHEN ORDERING BRAKES, PLEASE SPECIFY THE FOLLOWING:

- Speed and Capacity of the Machine
- Distance from the Center Line of the Worm Shaft to the Top of the Bedplate
- Voltage & Type of Motor Control

#### DIMENSIONS (INCHES)

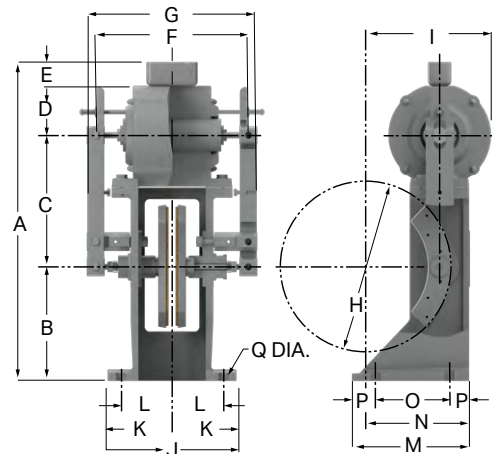

BRAKE NO.	A	B	C	D	E	F	G	H	I	J	K	L	M	N	O	P	Q	SHIP. WGT.
92	18 5/8	7	7 1/16	2 15/16	15/8	8 15/16	11 5/8	10	7 1/16	6 1/4	3 1/8	2 5/8	6	5 5/8	4 1/2	3/4	9/16	85#
102	21 7/8	7 3/4	9	3 1/2	15/8	10 1/2	11 5/8	12	8 1/2	9	4 1/2	3 5/8	8	7	5	1 1/2	11/16	95#
112	25 1/2	11 3/8	9	3 1/2	15/8	10 1/2	11 5/8	14	9 1/2	9	4 1/2	3 5/8	8	7	5	1 1/2	11/16	100#

# BRAKES & ACCESSORIES

## DC DRUM BRAKES



Hollister-Whitney offers Direct Current Brakes that feature a completely enclosed coil, individual spring tension adjustments, individual stroke adjustments, and pivot shoes with toe and heel adjustments. They are easy to install and adjust (*split frame*).

Operating voltage on Brake Coil is 230 Volts D.C. (115 Volts Optional). When using 230-volt coil, voltage may be decreased to 160 volts for running and holding. For 115-volt coil, voltage may be decreased to 85 volts for running and holding. D.C. Rectifier Panels, Transformer and Split Brake Drums available. Modifications available for non-standard drum diameters and widths.

## ELECTRICAL INFORMATION

**MODELS 80 - 111**

	Optional 115V	Standard 230V
<b>Ohms</b>	71	280
<b>Amps</b>	1.63	.82
<b>Watts</b>	189	188

**MODELS 115 - 121**

	Optional 115V	Standard 230V
<b>Ohms</b>	84	313
<b>Amps</b>	1.38	.73
<b>Watts</b>	160	167

## WHEN ORDERING BRAKES, PLEASE SPECIFY:

- Diameter and Width of the Brake Drum
- Distance from the Center Line of the Brake Drum to the Top of the Bedplate
- Voltage
- Control (Single Speed, 2 Speed, V.V., or V.F.A.C.)
- Capacity and Speed
- Amount of Existing Shoe Contact on Drum.

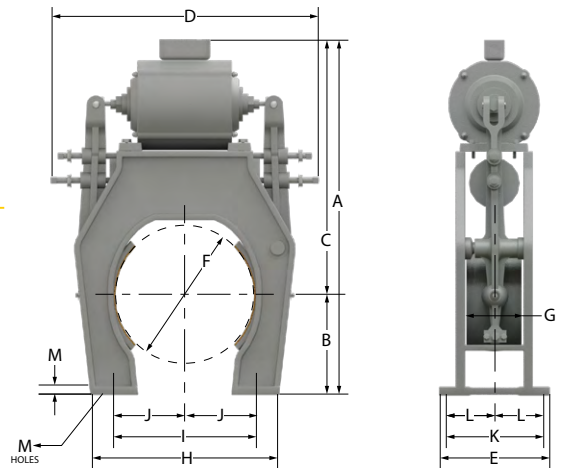

ASSY. NO.	SIZE	A	B	C	D	E	F	G	H	I	J	K	L	M	N	SHIP. WGT.
80	8H	26 1/8	7 5/16	19	18	8 1/4	8	3 5/8	13 1/2	10	5	7	3 1/2	5/8	9/16	190#
85	9H	26 1/8	7 5/16	19	18	8 1/4	9	3 5/8	13 1/2	10	5	7	3 1/2	5/8	9/16	165#
86	9L	24 1/2	5 1/2	19	18	8 1/4	9	3 5/8	14	10	5	7	3 1/2	5/8	9/16	165#
90	10H	26 1/8	7 5/16	19	18	8 1/4	10	3 5/8	13 1/2	10	5	7	3 1/2	5/8	9/16	160#
91**	10L	24 1/2	5 1/2	19	18	8 1/4	10	3 5/8	14	10	5	7	3 1/2	5/8	9/16	160#
95	11H	28 1/2	9 1/2	19	19	9 3/4	11	5 1/8	16 3/4	13	6 1/2	8 1/2	4 1/4	5/8	9/16	190#
96**	11L	25 1/2	6 1/2	19	19	9 3/4	11	5 1/8	16 7/8	13	6 1/2	8 1/2	4 1/4	5/8	9/16	190#
100	12H	28 1/2	9 1/2	19	19	9 3/4	12	5 1/8	16 3/4	13	6 1/2	8 1/2	4 1/4	5/8	9/16	190#
101**	12L	25 1/2	6 1/2	19	19	9 3/4	12	5 1/8	16 7/8	13	6 1/2	8 1/2	4 1/4	5/8	9/16	190#
105	13H	32 1/4	11 3/8	20 7/8	20	10 1/2	13	5 1/2	19	15 1/4	7 5/8	9	4 1/2	5/8	9/16	215#
106	13L	28 1/4	7 1/2	20 7/8	20	10 1/2	13	5 1/2	19 1/4	15 1/4	7 5/8	9	4 1/2	5/8	9/16	215#
110	14H	32 1/4	11 3/8	20 7/8	20	10 1/2	14	5 1/2	19	15 1/4	7 5/8	9	4 1/2	5/8	9/16	215#
111**	14L	28 1/4	7 1/2	20 7/8	20	10 1/2	14	5 1/2	19 1/4	15 1/4	7 5/8	9	4 1/2	5/8	9/16	215#
115	15H	35 5/8	13	20 7/8	23	11	15	6 1/8	20	16	8	9 3/4	4 7/8	5/8	9/16	250#
116	15L	31 5/8	9	20 5/8	23	11	15	6 1/8	20 3/4	16	8	9 3/4	4 7/8	5/8	9/16	250#
120	16H	35 5/8	13	20 5/8	23	11	16	6 1/8	20	16	8	9 3/4	4 7/8	5/8	9/16	250#
121**	16L	31 5/8	9	20 5/8	23	11	16	6 1/8	20 3/4	16	8	9 3/4	4 7/8	5/8	9/16	250#

\*\* These low brakes are available for pickup ONLY, at G.A.L. Bronx, New York. All brake shoes that have to be shipped to various locations must be ordered from Hollister-Whitney, Quincy, Illinois.

PART ID	PART DESCRIPTION
HW-100-008	EYE BOLT
HW-100-029A	BRAKE SHOE ASSEMBLY - 12"
HW-100-048	LEVER & SHOE ASSEMBLY - 12"
HW-100-094	DRUM BRAKE MONITOR ASSY 100 & 110
HW-102-006	PLUNGER - BRAKE
HW-102-007	PLUNGER - BRAKE W/PLUNGER RING
HW-102-009	BRASS PLUNGER TUBE 2.375X6.50 44/54/64
HW-102-059	EYEBOLT-SPRING (revised - only after 2003 models)
HW-102-061	ASSEMBLY - DISC BR. SHOE & ROD SET(2)
HW-102-064	EYEBOLT - SLOTTED PLUNGER
HW-102-073	COIL PER PRINT, 230VDC CLASS F (P-21444)
HW-102-074	115VDC BRAKE COIL, CLASS F (SNC P-21445)
HW-102-078	BRASS BUMPER WASHER 2" OD x 1" ID x 1/32
HW-102-094	DISC BRAKE MONITOR ASSY 102 & 112
HW-102-095	DISC BRAKE MONITOR ASSY 102 & 112 GOLD
HW-102-115V	12" DISC BRAKE--115V--SELL W/102-094/95
HW-102-230V	12" DISC BRAKE--230V--SELL W/102-094/95
HW-110-029A	BRAKE SHOE ASSEMBLY - 14"
HW-110-038	3/8" HHCS WITH NYLON INSERT - 2-1/2" LG.
HW-110-048	LEVER & SHOE ASSEMBLY - 14"
HW-112-115V	14" DISK BRAKE--115V--SELL W/102-094/95
HW-112-230V	14" DISK BRAKE--230V--SELL W/102-094/95
HW-120-006	PLUNGER - BRAKE
HW-120-007	PLUNGER - BRAKE W/PLUNGER RING
HW-120-009	BRASS PLUNGER TUBE 3.125 x 10.06 74 MACH
HW-120-022	230 VOLT COIL FOR 120 BRAKE
HW-120-035	115 VOLT COIL FOR 120 BRAKE
HW-120-094	DRUM BRAKE MONITOR ASSY 120
HW-143-004	RSD10 4 BRAKE PADS
HW-144-004	RSD8 FRICTION LINING KIT W/2 PADS
HW-146-004	RSD6 FRICTION LINING KIT W/2PADS
HW-146-005	RSD6, RSD8, & RSD10 SWITCH KIT W/SCREWS



HW-102-061



HW-102-073



HW-102-094



HW-102-115V



HW-110-029A



HW-110-048



HW-120-035

PART ID	PART DESCRIPTION
HW-146-A-72-A	SPRAY PAINT - H-W GRAY
HW-146-L-17-A	SPRAY PAINT - H-W BLUE
HW-90-006	PLUNGER - BRAKE
HW-90-007	PLUNGER - BRAKE W/PLUNGER RING
HW-90-009	BRASS PLUNGER TUBE 2.75 x 8.06 43/53/63
HW-90-016	NYLON BUSHING - LEVER
HW-90-022	230 VDC COIL
HW-90-029A	BRAKE SHOE ASSEMBLY - 10"
HW-90-032	TRUARC RING #5133-62 (PLUNGER PIN)
HW-90-033	TRUARC RING #5133-74 (LEVER PIN)
HW-90-035	115 VOLT COIL
HW-90-038	BOLT W/NYLON INSERT (3/8" x 2-1/4" Lg)
HW-90-044	OILITE BUSHING (LEVER)
HW-90-048	LEVER & SHOE ASSEMBLY - 10"
HW-90-078	CUSHION 2 3/8" OD x 1 3/8 ID x 1/32 BRASS
HW-90-094	DRUM BRAKE MONITOR ASSY 90
HW-92-006	PLUNGER - BRAKE
HW-92-007	PLUNGER - BRAKE W/PLUNGER RING
HW-92-009	BRASS PLUNGER TUBE 34 MACH
HW-92-022	COIL 230 VDC (SNC P-19081)
HW-92-035	COIL 115VDC
HW-92-059	EYEBOLT- SPRING HOUSING
HW-92-061	ASSEMBLY - DISC BR. SHOE & ROD SET(2)
HW-92-064	EYEBOLT - SLOTTED PLUNGER
HW-92-078	PLUNGER CUSHION 1" OD x .25 ID BRASS 1/32
HW-92-094	DISC BRAKE MONITOR ASSY 92 BRAKE
HW-92-115V	DISC BRAKE - 10" (115V) SELL W/92-094/095
HW-92-230V	DISC BRAKE - 10" (230V) SELL W/92-094/095



HW-92-009



HW-92-022



HW-92-035



HW-92-061



HW-92-064

# GEARED MACHINE PARTS

PART ID	PART DESCRIPTION
HW-34-081-1	SPLIT CLIPPER SEAL R-0150-09628 RUP
HW-34-091	THRUST BEARING PAIR (7405)
HW-34-112S	ZEE BRACKET
HW-34-107S	RUBBER PAD PER PRINT 70 DURO NEOPRENE
HW-34-131	ISOLATION RUBBER (1"x 5"x 7")
HW-34-131S	ISOLATION RUBBER (1"x 5"x 6")
HW-34-203	THRUST NUT KIT - BEARING END
HW-34-303	ISOLATION BRACKET SHIM
HW-43-091	THRUST BEARING PR (7406)
HW-43-123-1	MACHINE PAN 16GA 16 3/4" X 29 1/2"
HW-43-188	BEARING & SEAL ASSY. - COMPLETE MACHINE
HW-43-189	BEARING & SEAL ASSY. - MAIN SHAFT
HW-43-190	SEAL & GASKET ASSY. - COMPLETE MACHINE
HW-44-203	THRUST NUT KIT - BEARING END
HW-53-081-1	SPLIT SEAL
HW-53-091	THRUST BEARING PR (7407)
HW-53-103	TAPER PIN - #7 X 3" THREADED
HW-53-188	BEARING & SEAL ASSY. - COMPLETE MACHINE
HW-53-189	BEARING & SEAL ASSY. - MAIN SHAFT
HW-53-190	SEAL & GASKET ASSY. - COMPLETE MACHINE
HW-54-203	THRUST NUT KIT - BEARING END
HW-63-081-1	SPLIT REPLACEMENT WORM SHAFT SEAL
HW-63-091	THRUST BEARING PAIR (7409)
HW-63-188	BEARING & SEAL ASSY. - COMPLETE MACHINE
HW-63-189	BEARING & SEAL ASSY. - MAIN SHAFT
HW-63-190	SEAL & GASKET ASSY. - COMPLETE MACHINE
HW-SHC-636	MOBILE SHC636 1 GALLON GEAR OIL



HW-34-091



HW-34-106



HW-34-107



HW-63-081



HW-63-091

PART ID	PART DESCRIPTION
HW-64-203	THRUST NUT KIT - BEARING END
HW-74-081-1	SPLIT SEAL
HW-74-091	THRUST BEARING PAIR (7413)
HW-74-188	BEARING & SEAL ASSY. - COMPLETE MACHINE
HW-74-189	BEARING & SEAL ASSY. - MAIN SHAFT
HW-74-190	SEAL & GASKET ASSY. - COMPLETE MACHINE
HW-74-203	THRUST NUT KIT - BEARING END
HW-SHC-524	FULL SYNTHETIC MOBIL 1 GRIPPER OIL 1GL
HW-SHC-636	MOBIL SHC636 1 GALLON GEAR OIL

# MACHINE ISO PADS

PART ID	PART DESCRIPTION
HW-34-107S	**LS**ZEE BRACKET
HW-34-112S	**LS**RUBBER PAD(Z BRCKT) 6" WIDE X 2-5/8
HW-53-109	ISOLATION RUBBER (1" x 4" x 9")
HW-53-131	ISOLATION RUBBER (1" x 7" x 9")
HW-53-131S	ISOLATION RUBBER (1"x 7"x 6")
HW-74-109	ISOLATION RUBBER (1"x 4"x 12")
HW-74-131	ISOLATION RUBBER (1"x 7"x 12")



HW-34-112S



HW-53-131

# ENCODER CABLES

PART ID	PART DESCRIPTION
HW-00.F5.0C1-4015	KEB CABLE 15 METER 17PIN
HW-00.F5.0C1-4020	KEB CABLE 20 METER 17PIN
HW-00.F5.0C1-4030	KEB CABLE 30 METER 17PIN
HW-00.F5.0C1-L040	KEB CABLE 40 METER 17PIN
HW-00.F5.0C1-L050	KEB CABLE 50 METER 17PIN
HW-ENC-1024	TURCK ENCODER WITH 11 METER CABLE
HW-ENC-113	ID# 810800-61 ENCODER 2048 PPR 50MM
HW-ENC-2048	TURCK ENCODER WITH 11 METER CABLE
HW-SKC8T-930-11	TURCK ENCODER CABLE 11M, ENC-C11M
HW-SKC8T-930-15	TURCK ENCODER CABLE 15M, 50FT
HW-SKC8T-930-20	TURCK ENCODER CABLE 20M 62.5FT
HW-SKC8T-930-23	TURCK ENCODER CABLE 23M 75FT
HW-309778-20	CONNECTING CABLE (VBK) 20 METER
HW-309778-40	CONNECTING CABLE (VBK) 40 METER
HW-309778-50	CONNECTING CABLE (VBK) 50 METER
HW-309778-A1	CONNECTING CABLE (VBK) 100 METER



HW-00.F5.0C1-4020



HW-ENC-113

# RAIL GUIDE ASSEMBLIES AND PARTS

## ROLLER GUIDE SHOES

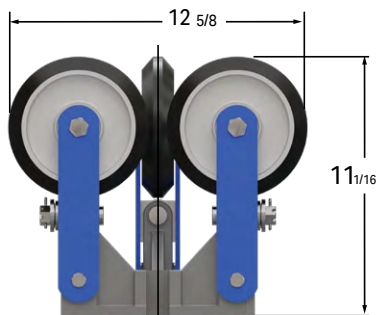
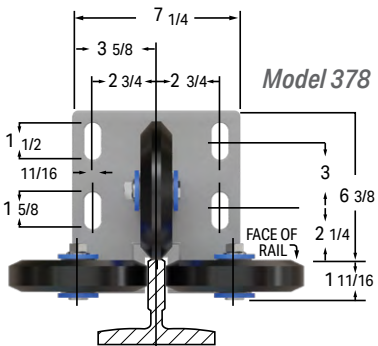
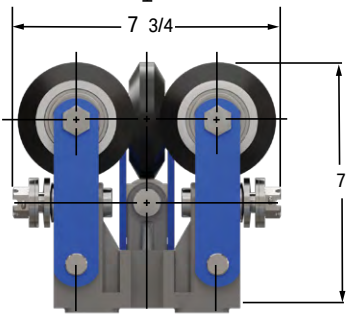
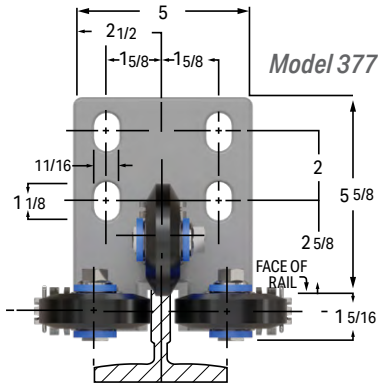

### OUTSTANDING FEATURES BUILT INTO H-W ROLLER GUIDES

- WIDER ROLLERS FOR RAIL SIDES EXTEND LIFE
- SEALD PRELOADED BEARINGS
- DOUBLE ARMS WITH SPRING IN CENTER PREVENT TWISTING
- CASTING WITH WEBBING FOR STRENGTH — PRECISION MACHINED TO ASSURE ALIGNMENT OF THREE FACES
- HIGH THROAT FOR POSSIBLE TIRE FAILURE
- SET SCREW FOR BASE OF ALIGNMENT
- HEAVY DUTY POLYURETHANE PRECISION ROLLER
- BONDING WITH LATEST TECHNOLOGY TO ENSURE NON-SEPARATION OF POLYURETHANE FROM WHEEL HUB
- INDUSTRY STANDARD MOUNTINGS
- DOUBLE ACTION TENSION DEVICE FOR LOAD-CONSCIOUSNESS IS FACTORY SET — NO FIELD ADJUSTMENT REQUIRED AND NO STOPS NECESSARY

Roller Guide Shoes from H-W are "Load Conscious!" The unique tension system actually causes the rollers to "feel" or "sense" the rail and adjust for loads near the balanced point and for rail misalignment, while a strong tension takes over to prevent excessive movement as heavier loads are placed off center. Rollers will never leave the rail with this "guide" and the outstanding tension system allows ultra long life of the roller wheels.

For higher capacities, the ultimate choice is the Hollister-Whitney four-wheel guides. Four wheels control more of the side to side movement.

APPLICATION FOR  
TYPICAL ELEVATOR  
INSTALLATION

MODEL NO. & SHOE TYPE	WHERE USED & RAIL SIZE	TYPE LOADING	MAX CAR CAP.	CAR SPEED OF	WEIGHT SET OF 4
377 3-3 1/4" Rollers	Car	Pass.	2000	300	<b>55#</b>
	Cwt.	Pass.	5000	600	
378 3-6" Rollers	Car 5/8" or 3/4" (EXCEPT 8 lbs)	Pass.	4000	600	<b>110#</b>
		Class "A" Frt.	4000	200	
379 4-3 1/4" Rollers	Car	Pass.	3500	300	<b>75#</b>
	Cwt.	Pass.	8000	1000	
380 4-6" Rollers	Car 5/8" or 3/4" (EXCEPT 8 lbs)	Pass.	8000	1000	<b>175#</b>
		Class "A" Frt.	6000	200	

NOTE: Contact H-W for capacity and speeds greater than shown.

NOTE: Models 378 & 380 are not designed for use on 8# rails.



Model 379

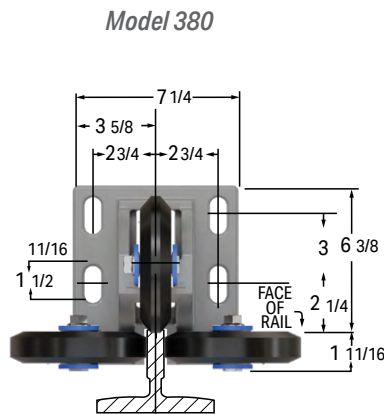
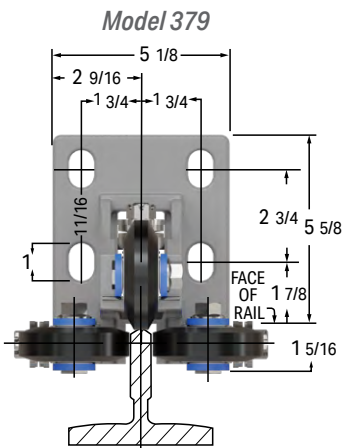

Model 380

PART ID	PART DESCRIPTION
HW-371-003	LINER (15# RAIL)
HW-371-004	LINER (18-1/2# RAIL)
HW-371-005	LINER (22# RAIL)
HW-371-006	LINER (30# RAIL)
HW-371-CI	GUIDE SHOE ASSEMBLY
HW-371-CS	GUIDE SHOE ASSEMBLY (CAST STEEL)
HW-374-004	LINER - NYLON
HW-375	GUIDE SHOE ASSEMBLY (CWT)
HW-375-002	LINER - NYLON
HW-376	COUNTERWEIGHT SHOE
HW-377	ROLLER GUIDE ASSEMBLY
HW-377-012A	REPLACEMENT ROLLER 3-1/4" (FACE) 1/2"
HW-377-013A	REPLACEMENT ROLLER 3-1/4" (SIDE) 3/4"
HW-378	ROLLER GUIDE ASSEMBLY (CAR)
HW-378-012A	REPLACEMENT ROLLER 6" (FACE) 1/2"
HW-378-013A	REPLACEMENT ROLLER 6" (SIDE) 7/8"
HW-379	ROLLER GUIDE ASSEMBLY (CWT)
HW-380	ROLLER GUIDE ASSEMBLY (CAR)
HW-381	RIGID GUIDE SHOE ASSEMBLY W/O LUBRICATOR
HW-381-005	LUBRICATOR ASSEMBLY
HW-382	GUIDE SHOE ASSEMBLY (CAR)
HW-383	GUIDE SHOE ASSEMBLY (CWT)
HW-500-14	BUFFER SWITCH



HW-371-CS



HW-377



HW-377-012A



HW-377-013A



HW-500-014



HW-380



HW-381

# OIL BUFFERS



500 Oil Buffer with NEMA Switch



500 Oil Buffer with GAL Switch

The Hollister-Whitney Series 500 Oil Buffers answer your need for easy-to-install, reliable, and rugged car and counterweight oil buffers. These buffers are readily mountable wherever reliable oil buffers are needed. Series 500 Oil Buffers are designed and built to strict engineering standards and conform to ASME A17.1 and C.S.A. B44 safety codes. They also conform to New York City Housing Authority specifications and have Material and Equipment Acceptance (MEA) approval from the City of New York Department of Buildings.

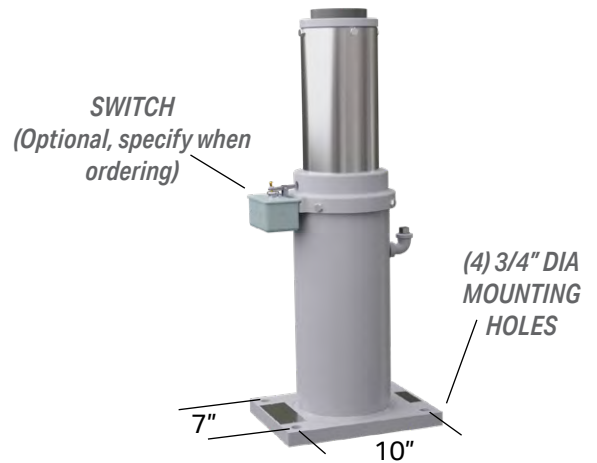

## WHEN ORDERING OIL BUFFER, PLEASE SPECIFY THE FOLLOWING

- Rated Car Speed
- Rated Car Capacity
- Empty Car Weight
- Total Counterweight Weight
- With or Without Switch
- If Car Buffer Strut is Required
- If Pit Channels are Required

ASSY. NO.	STROKE	OVERALL HEIGHT	COMP. HEIGHT	MAX. CAR SPEED	GROSS LOAD (LBS.)		SHIP. WGT.
					MIN	MAX.	
500	9"	30"	21"	350 FPM	2,500	15,000	150#
510	12"	37"	25"	400 FPM	2,500	15,000	180#



# ELEVATOR CONTROLS PARTS

# RELAYS & CONTACTORS

PART ID	PART DESCRIPTION
EC-04-001-020	TYCO K10 DPDT 11mA COIL 120VAC, 15A@120VA
EC-04-001-023	4 POE 6A 24VDC/AGCDO RELAY RU4S-D-24
EC-04-002-004	2-POLE 20A 120VAC COIL POWER RELAY
EC-12-020-023B	3 POLE CONTACTOR, 1 NC AUXILIARY CONTACT
EC-12-020-062B	3 POLE CONTACTOR, 1 NC AUXILIARY CONTACT
EC-14-002-003	24VDC 120W, SWITCHING POWER SUPPLY



EC-04-001-023



EC-12-020-062B



EC-17-002-116V02



EC-14-002-003

# PC BOARDS

PART ID	PART DESCRIPTION
EC-17-002-114Vnn	PIXEL HALL NODE BOARD ASSEMBLY
EC-17-002-116Vnn	PIXEL EXPANSION I/O BOARD ASSEMBLY
EC-17-002-119Vnn	PIXEL CAR OPERATING PANEL MICROPROCESSOR
EC-17-002-121Vnn	PIXEL TOP OF CAR MICROPROCESSOR BOARD
EC-17-002-123Vnn	PIXEL MAIN MICROPROCESSOR BOARD
EC-17-002-124Vnn	PIXEL SAFETY PROCESSOR I/O BOARD
EC-17-002-129Vnn	PIXEL POWER DISTRIBUTION
EC-17-002-135Vnn	PIXEL HALL NETWORK ADAPTER BOARD
EC-17-002-141Vnn	PIXEL POWER DISTRIBUTION FOR HYDRO



EC-17-002-119V03



EC-17-002-123V02



EC-17-002-123V04



EC-17-002-124V05

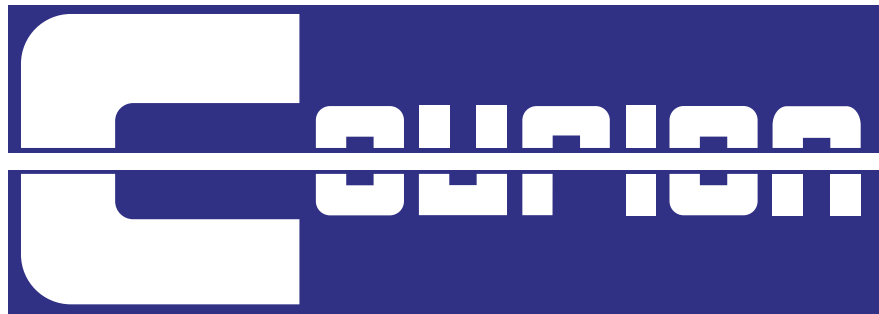

# COURION FREIGHT DOORS PARTS

# FREIGHT DOOR OPERATORS

PART ID	PART DESCRIPTION
CRN-02-198601	OPERATOR, DUAL DESIGN
CRN-02-250000L	OPERATOR, "Q" POWER DOOR OPERATOR LH
CRN-02-250000R	OPERATOR, "Q" POWER DOOR OPERATOR RH



CRN-02-250000L

# LIMIT SWITCHES & PARTS

PART ID	PART DESCRIPTION
CRN-04-250000L	QLSII LIMIT SWITCH, LH
CRN-04-250000R	QLSII LIMIT SWITCH, RH
CRN-04-399929L	INTERLOCK, PAE LH
CRN-04-399929R	INTERLOCK, PAE RH
CRN-04-550001	SWITCH, DOOR LIMIT
CRN-04-700000	I SENSOR DOOR



CRN-04-399929L



CRN-04-250000R



CRN-04-700000

# CAMS & SWITCH ASSEMBLIES

PART ID	PART DESCRIPTION
CRN-06-298001L	RETIRING CAM ASSEMBLY, LH
CRN-06-298001R	RETIRING CAM ASSEMBLY, RH
CRN-06-520000	POWER UNIT, RETIRING CAM "Q"
CRN-07-210000L	QGS GATE SWITCH ASSEMBLY, LH
CRN-07-210000R	QGS GATE SWITCH ASSEMBLY, RH

# OTHER DOOR PARTS

PART ID	PART DESCRIPTION
CRN-08-899505	EMERGENCY UNLOCKING DEVICE
CRN-09-430670	CHAIN&BOLT, #6-69-3/8" LONG W/KIT(PR)
CRN-09-430682	CHAIN & BOLT ASSEMBLY, PAIR 81" W/HDWE.
CRN-09-800332	WEB STRAP, 32" (UP TO 8'1" OP. HT.)
CRN-09-800356	WEB STRAP, 56" (UP TO 10'1" OP. HT.)
CRN-09-800374	WEB STRAP, 74" (UP TO 11'7" OP. HT.)
CRN-09-870033	KIT, LF96 SHOES (4 PER PACKAGE)
CRN-21-240000L	INTERLOCK, QIP LH
CRN-21-240000R	INTERLOCK, QIP RH
CRN-21-740000	GLS, GEARED LIMIT SWITCH
CRN-21-750000	DRIVE UNIT ASSEMBLY
CRN-90-514512	POWER SUPPLY, UNIVERSAL
CRN-90-514520	LIGHT CURTAIN, MINI (-) 5 METERS



CRN-08-899505



CRN-90-514520

# DOOR MOTORS

PART ID	PART DESCRIPTION
CRN-90-852400	MOTOR, 16 OZ CAM 230V, 0.8 AMPS 600 RPM
CRN-90-852600	MOTOR, 16 OZ DOOR 230V, 0.9 AMPS
CRN-90-852800	MOTOR, 32 OZ DOOR 230V, 1.6 AMPS
CRN-90-853300	MOTOR, 32 OZ GATE 230V, 1.6AMPS *CSA*
CRN-90-853500	MOTOR, 65 OZ GATE 230V, 3.2AMPS *CSA*
CRN-90-854000	MOTOR, LP25 DOOR LOW PROF. .05HP 3PH 60HZ



CRN-90-852600

**RENEW** hydro™**HYDRAULIC ELEVATOR  
MODERNIZATION  
MADE EASY****REQUEST****QUOTE****ORDER**

Introducing our **RENEW** hydro™ modernization solution offering customers five key hydraulic products in one, reducing complexity and loss of valuable time.

**RENEW** hydro™ simplifies demanding elevator modernization projects. Bundling the perfect combination of components from the Vantage product portfolio, you'll get everything you need to enhance safety, performance, and reliability, all from a single source.



# RENEW hydro™

## WHAT'S INCLUDED

Our **RENEW** hydro™ solution includes a controller, submersible pump unit, door equipment, fixtures and electrical package.



**CONTROLLER** 1

**SUBMERSIBLE PUMP UNIT** 2

**DOOR EQUIPMENT** 3

**FIXTURES** 4

**ELECTRICAL PACKAGE** 5

**PRICING INCLUDES SHIPPING COST** 6

# VANTAGE RENEW hydro™

## BENEFITS:

- Designated Project Manager
- Unmatched product and customer support, our regional field engineers are on standby 24/7
- Product Training for Technicians
- Labor savings for ordering and installation
- Includes our industry leading, non-proprietary, key system components -controller, submersible pump unit, door equipment, fixtures and an electrical package
- All products are pre-engineered and configurable
- Increased safety, reliability, ride quality and value

## GENERAL PRODUCT RANGE – AT-A-GLANCE:

- Simplex or duplex operation
- Speed: 50 – 150 fpm
- Capacity: 1500 – 5000 lbs.
- Stops (Maximum): 5
- Openings (Maximum): 10
- Rise (Maximum): 60'
- Loading: Class A (Passenger)
- Pump unit type: Submersible
- NEMA 1 machine room and hoistway condition
- 208 – 575 VAC, 3 Phase, 60 Hz | 220 VAC, 1 Phase, 60 Hz



**GAL** MOVFE - HL

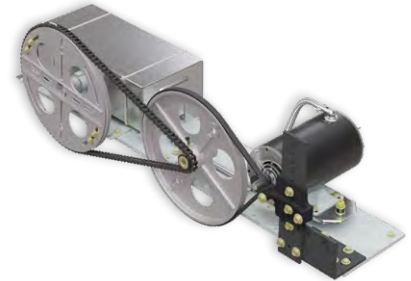

**GAL** MOVFR II



**BOREMAX** SUBMERSIBLE PUMP UNIT



**GAL** eHydro



**ELEVATOR CONTROLS** PIXEL HYDRO

# CLOSER TO OUR CUSTOMERS FOR BETTER SERVICE AND SUPPORT

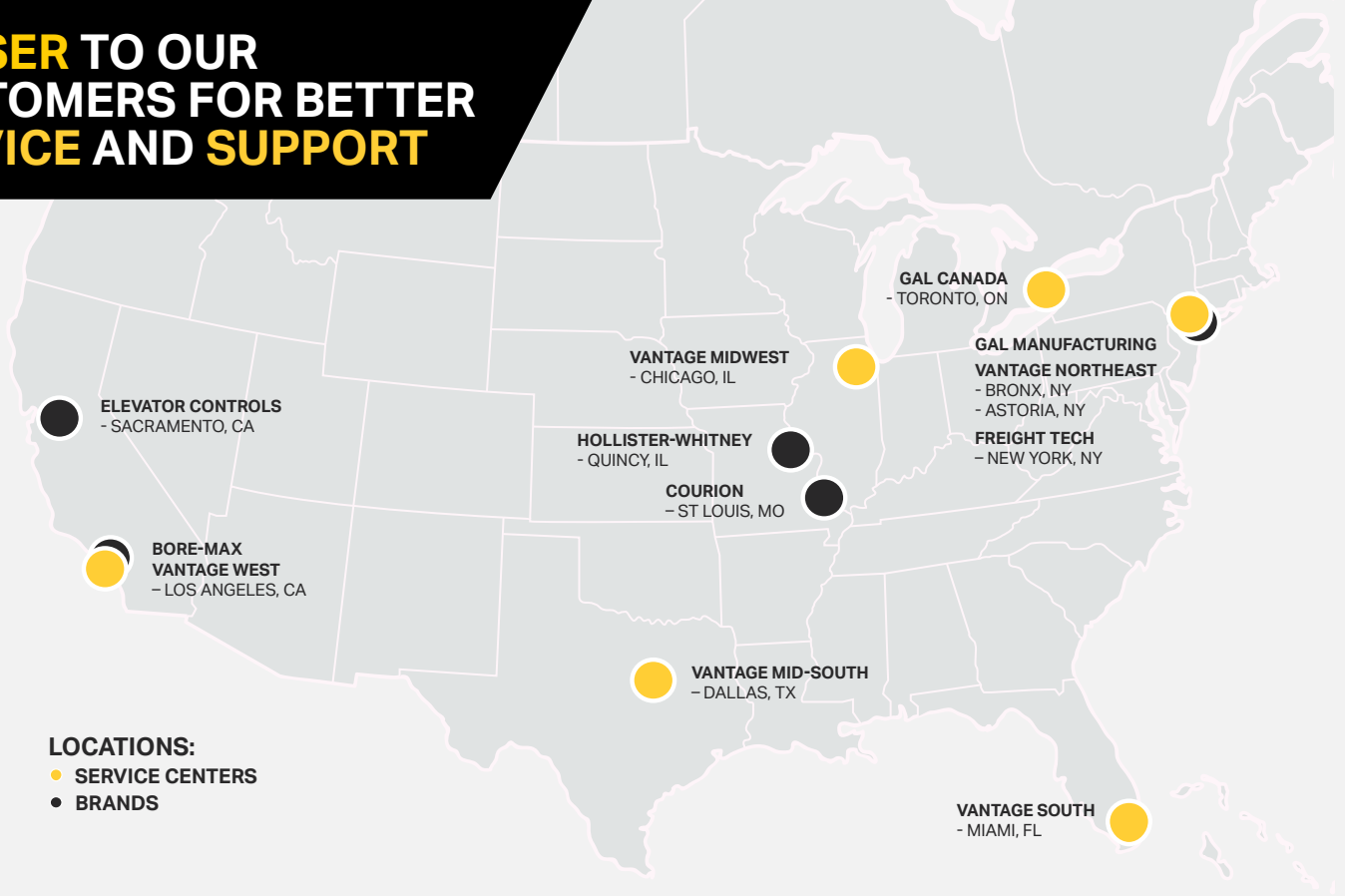

Our team offers customers the benefit of years of elevator experience earned both in the field and as suppliers to the elevator industry. With a commitment to providing quality service and anticipating customer needs, we continue to expand our locations to get even closer to our customer base.

## VANTAGE COMPANIES

Every Vantage business is rich in heritage. Our products and people are the best at what they do, and our resources are dedicated to the safe and reliable movement of people.



A VANTAGE Company



A VANTAGE Company



A VANTAGE Company



A VANTAGE Company



A VANTAGE Company



A VANTAGE Company



A VANTAGE Company



A VANTAGE Company



A VANTAGE Company



A VANTAGE Company

### REGIONAL SERVICE CENTERS



**NEW YORK - BRONX**  
50 E. 153rd St.  
Bronx, NY 10451  
917.336.4597

**NEW YORK - QUEENS**  
19-19 37th St.  
Astoria, NY 11105  
917.336.4597

**LOS ANGELES**  
9704 Jordan Circle,  
Santa Fe Springs, CA 90670  
877.300.5816

**CHICAGO**  
1930 East Devon Ave.  
Elk Grove Village, IL 60007  
877.300.5830

**MIAMI**  
15825 NW 15th Ave.  
Miami Gardens, FL 33169  
877.241.9354

**TORONTO**  
6500 Gottardo Ct.  
Mississauga, ON L5T 2A2  
888.425.2262

**DALLAS**  
3247 W. Story Road  
Irving, Texas 75038  
469.706.9316